

A B C D E F G H

| REVISIONS | | | | |
|-----------|------|---------------------------|----------|----------|
| ZONE | REV. | DESCRIPTION | DATE | APPROVED |
| - | - | INITIAL RELEASE, ECO#1742 | 06/17/10 | JRJ |

1
2
3
4

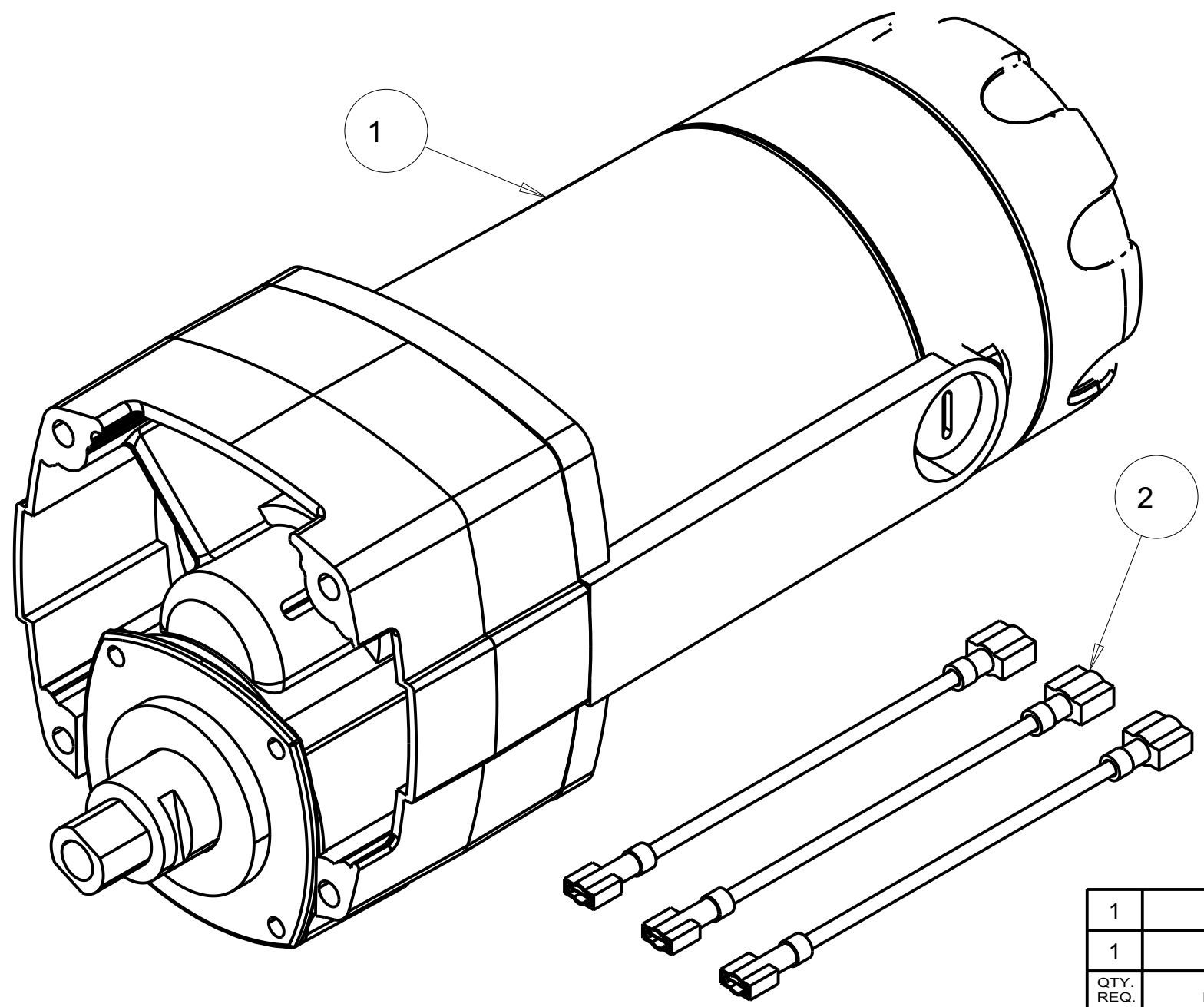

| | | | |
|-----------|-------------------------|-------------------------------|----------|
| 1 | 168523 | WIRE HARNESS, TX-3 MOTOR REPL | 2 |
| 1 | 157801-C | MTR, 115V, 15A, AC | 1 |
| QTY. REQ. | PART OR IDENTIFYING NO. | DESCRIPTION | ITEM NO. |

| PARTS LIST | | | |
|-----------------------------------------------------|--|---------------------------------------------------------------------------------------------------------------------------------------------------------------------------------------------------------------------------------------------------------|--------------------------------------------------------------------------------------------------------------------------------------------------------------------------------------------------------------------------------------|
| TOLERANCES UNLESS OTHERWISE SPECIFIED | | DATE | |
| DIMENSIONS ARE IN INCHES | | DRAWN | JRJ 06/17/10 |
| WHOLE NO. AND FRACTIONS = 1/16 (EXCEPT DRILL HOLES) | | CHECK | SMH 06/17/10 |
| .X = ±.03 | | DESIGN | JRJ 06/17/10 |
| .XX = ±.010 | | NEXT ASSY. | |
| .XXX = ±.005 | | - | |
| ANGLES = ±1/2° | | PROPRIETARY NOTICE: THIS DRAWING AND INFORMATION IT CONTAINS ARE THE PROPERTY OF MK DIAMOND INC. AND ARE CONSIDERED CONFIDENTIAL AND MAY NOT BE REPRODUCED, COPIED, OR USED IN PART OR IN WHOLE WITHOUT THE WRITTEN CONSENT OF MK DIAMOND PRODUCTS INC. | |
| DO NOT SCALE DRAWING | | APPLICATION SCALE: 0.750 | MK DIAMOND PRODUCTS INC. 1315 STORM PARKWAY TORRANCE, CA. 90509 MK-TX-3 TILE SAW MTR, TX-3 REPLACEMENT SIZE: B PART NO.: 157801-TX3 DWG. NO.: 157801-TX3 REV.: - SHEET: 1 of 1 |