



MK Diamond Products, Inc.

[www.mkdiamond.com](http://www.mkdiamond.com)

## MK-1280 CART ASSEMBLY



1280 Cart Instruction Sheet  
Part # 167437-IS



MK Diamond Products, Inc.

## MK-1280 CART ASSEMBLY

### CART ASSEMBLY (OPTIONAL ACCESSORY)

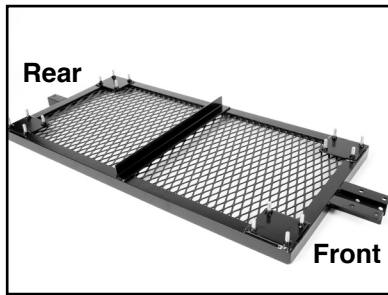

**Fig. A**  
Place cart upside down on a flat surface

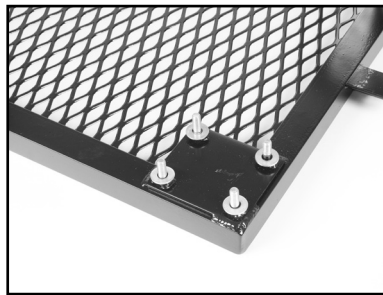

**Fig. B**  
Place one flat washer on each of the 16 bolts



**Fig. C**  
Place swivel casters on front bolts, followed by one flat washer, one lock washer and a nut. Tighten each nut to secure caster

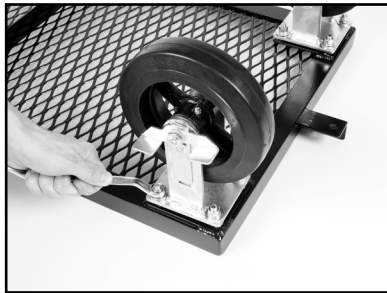
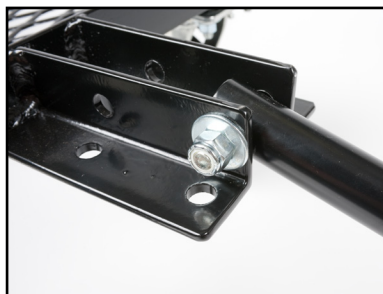

**Fig. D**  
Place stationary casters on rear bolts with brake facing out. Place one flat washer, one lock washer and a nut on each bolt. Tighten each nut to secure caster. Turn cart upright

### HANDLE ASSEMBLY



**Fig. A**  
Place handle in the middle of tow bracket. Slide one washer on to bolt and slide through hole



**Fig. B**  
Place washer and Nylok nut on end of bolt and tighten

## MK-1280 CART ASSEMBLY

### LOCK ASSEMBLY



**Fig. A**

Place one nut on each hook bolt.  
Thread nut 2/3 up the hook bolt



**Fig. B**

Place hook bolt through rear hole  
of tow bracket



**Fig. C**

Place washer on knob and thread  
knob on to hook bolt



**Fig. D**

Place Nylok nut on bottom of hook  
bolt and tighten. Repeat procedure  
for rear lock



**Fig. E**

Place saw on cart. Place hook bolt  
over saw handle. Tighten knob

### SETTING BRAKE



**Fig. A**

To set brake "on" the  
lever on back casters

#### NOTE:

The wheels and casters each have a zerk fitting that  
needs to be lubricated every 6 months or as needed.



# MK-1280 CART ASSEMBLY

## ASSY, CART - P/N 166581

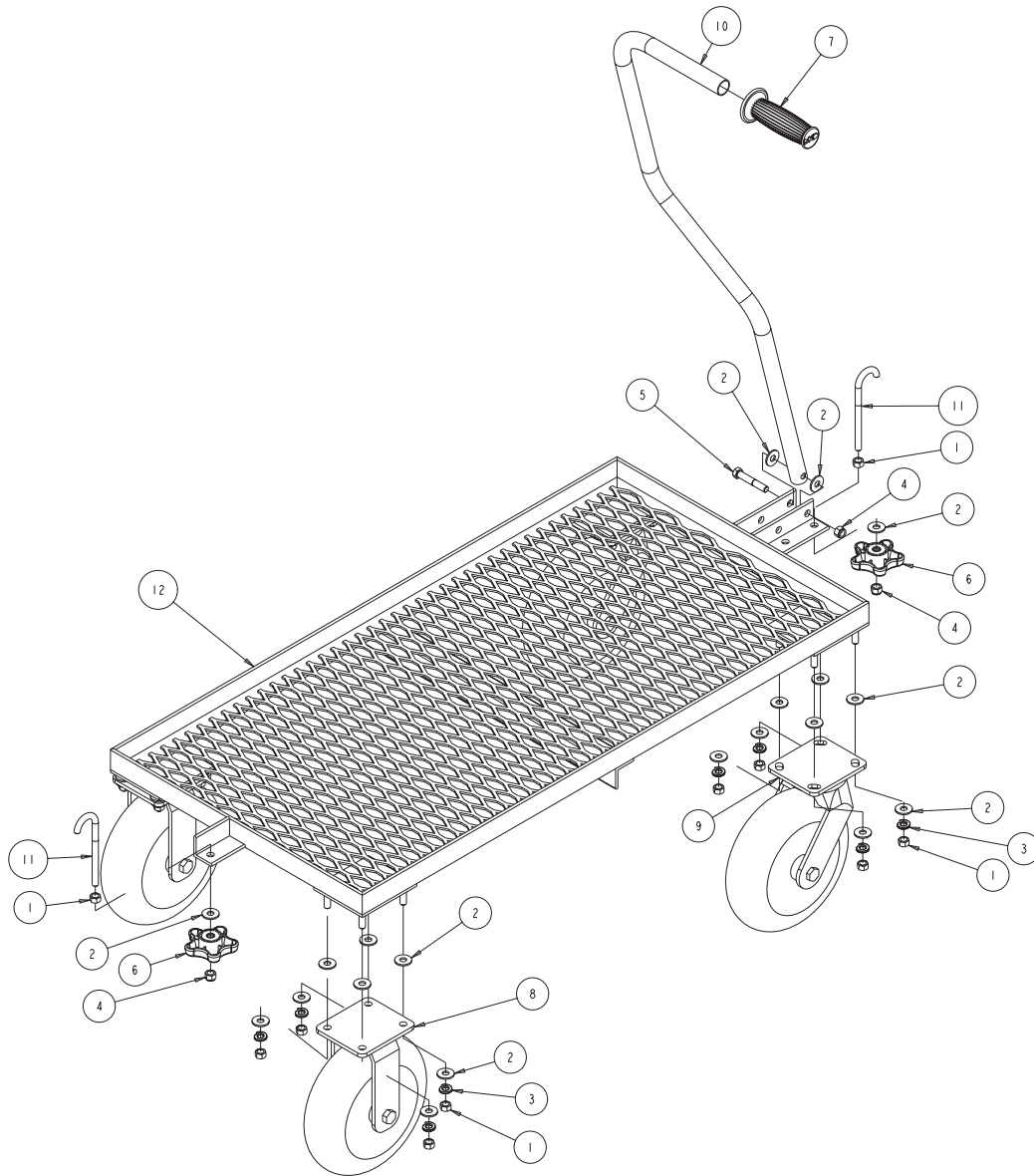

ITEM	DESCRIPTION	PART#	QTY
1	NUT, 3/8 - 16 HEX	101188	18
2	WASHER, FLAT, USS, 3/8	101360	36
3	WASHER, 3/8 SPLIT LOCK	150925	16
4	NUT, 3/8 - 16 NYLOK HEX	152505	3
5	SCREW, 3/8 - 16 X 2-1/4 HEX HEAD	153529	1
6	KNOB, ADJ MK1408 5-PRONG -RAW	155239	2
7	GRIP, HANDLE 7/8 ID	158608	1
8	CASTER, 10" RIGID	167772	2
9	CASTER, 10' SWIVEL	167773	2
10	HANDLE, CART	167774	1
11	BOLT, HOOK, 38 - 16 X 5	167775	2
12	FRAME, CART	167776	1