

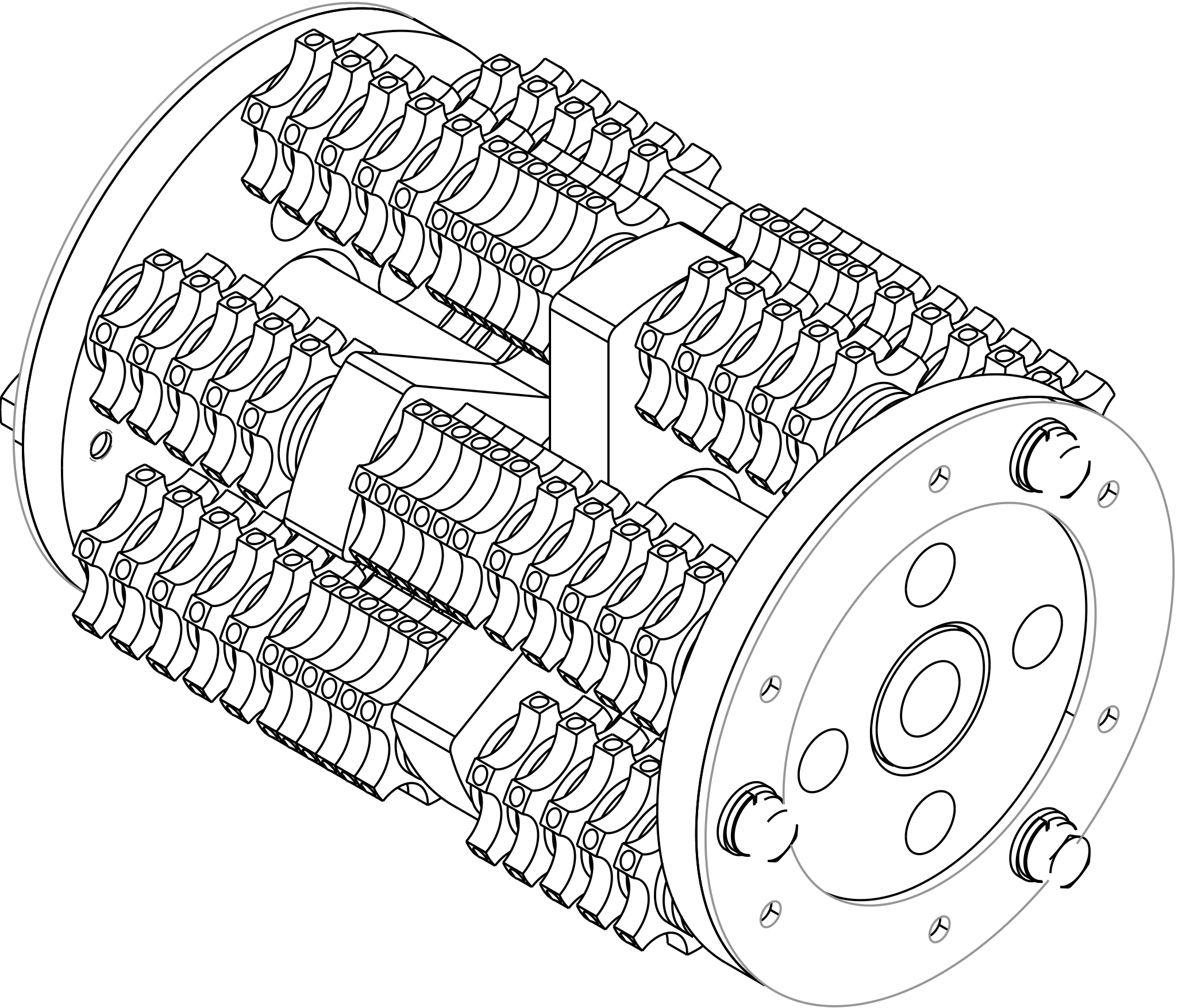

A B C D E F G H I J

REVISIONS				
ZONE	REV	DESCRIPTION	DATE	APPROVED
-	A	CREATE DRAWING, ECO1701#	03/17/10	JRJ
-	B	CHANGE STACK UP, ECO#2238	08/10/15	JRJ

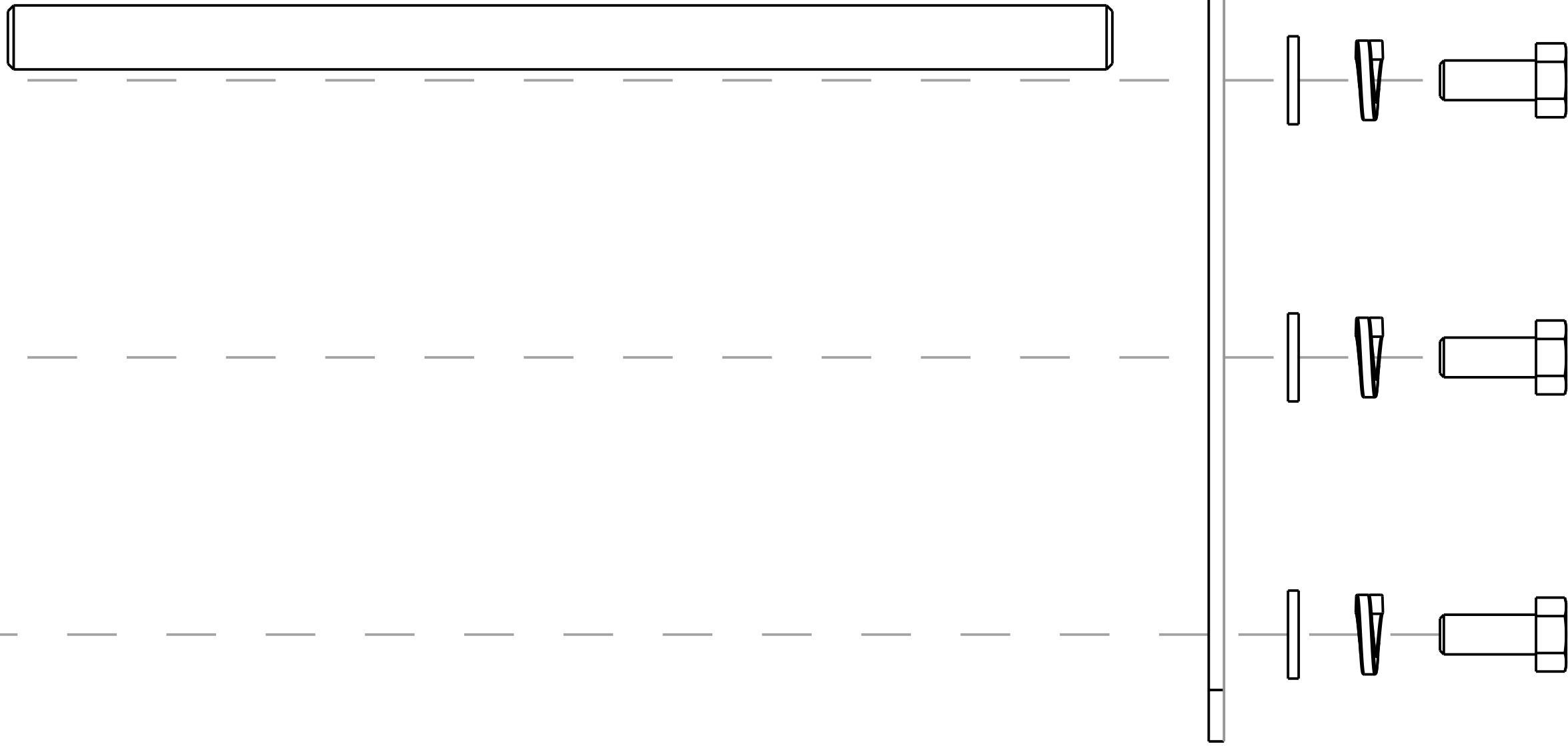
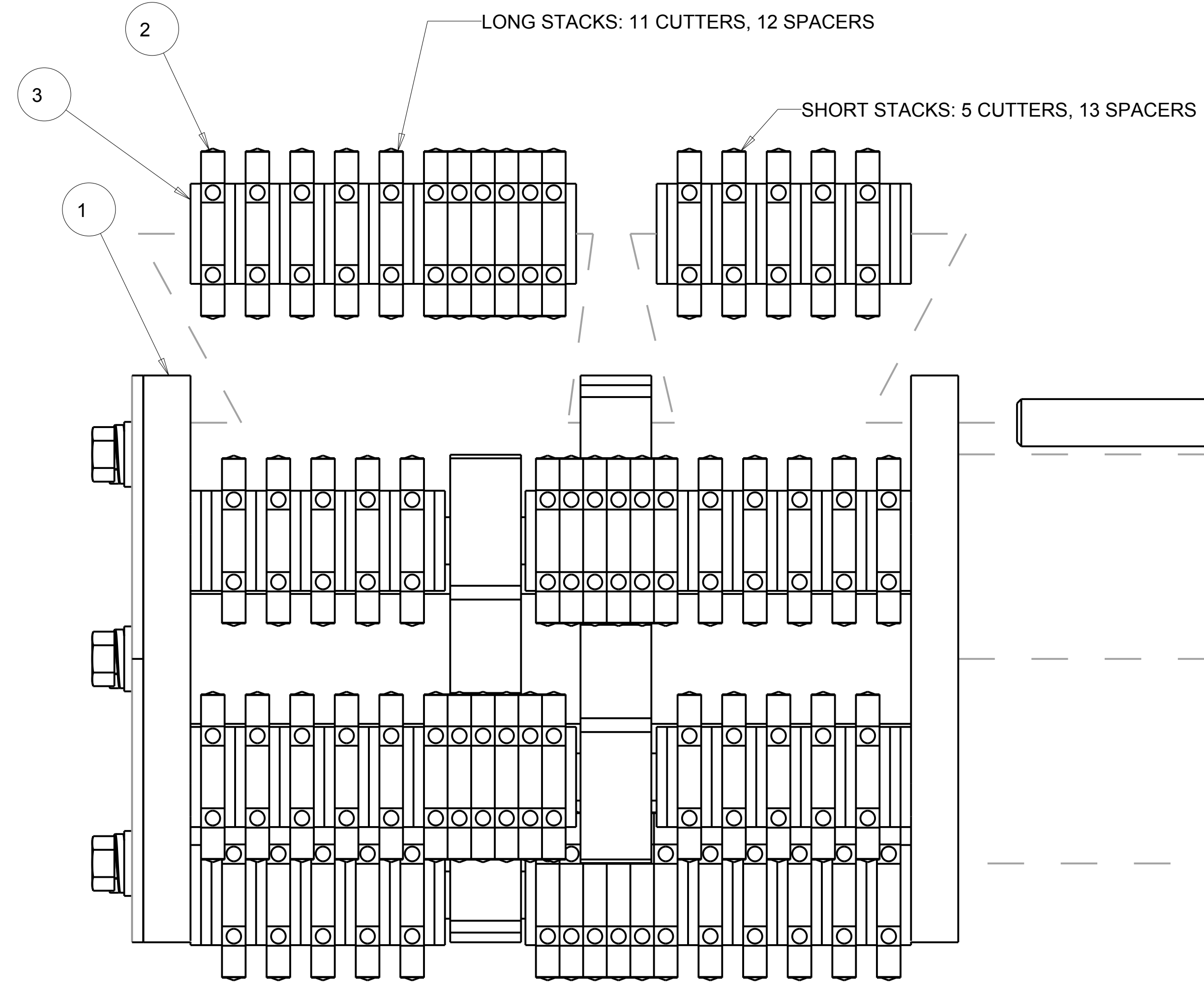

QTY. REQ.	PART OR IDENTIFYING NO.	DESCRIPTION	ITEM NO.
150	158575	SPACER, 1/2 HARDENED STEEL	3
96	158493	CUTTER, 6 POINT CARBIDE	2
1	158460	ASSY, SCARIFIER DRUM	1

PARTS LIST			
TOLERANCES UNLESS OTHERWISE SPECIFIED	DRAWN	JRJ	DATE
DIMENSIONS ARE IN INCHES	CHECK	SMH	03/17/10
WHOLE NO. AND FRACTIONS = 1/16 (EXCEPT DRILL HOLES)	DESIGN	-	03/17/10
X = ±.03	NEXT ASSY.		
XX = ±.010	-		
XXX = ±.005	PROPRIETARY NOTICE: THIS DRAWING AND INFORMATION IT CONTAINS ARE THE PROPERTY OF MK DIAMOND INC. AND ARE CONSIDERED CONFIDENTIAL AND MAY NOT BE REPRODUCED, COPIED, OR USED IN PART OR IN WHOLE WITHOUT THE WRITTEN CONSENT OF MK DIAMOND PRODUCTS INC.		
ANGLES = ±1/2°	 MK DIAMOND PRODUCTS INC. 1315 STORM PARKWAY TORRANCE, CA. 90509		
DO NOT SCALE DRAWING		APPLICATION	SCALE: 1:000
SIZE D		PART NO. 158584	DWG. NO. 158584
		REV B	SHEET: 1 of 1