

MK-212 SERIES PARTS LIST

MODELS	P/N
MK-212-4	159414
MK-212-4-SPCL	159414-SPCL
MK-212-6	167882



MK-212-4
P/N 159414



MK-212-6
P/N 167882

Revision 104	09.2019
Manual Part No. 159862-PM	

Caution: Read all safety and operating instructions before using this equipment. This owners manual **MUST** accompany the equipment at all times.

FIGURE 1 - MK-212-4 TILE SAW P/N 159414	4-5
FIGURE 2 - MK-212-4 MOTOR P/N 159414	6-7
FIGURE 3 - MK-212-4 TILE SAW W/12" CUTTING HEAD P/N 159414-SPCL	8-9
FIGURE 4 - MK-212-4 MOTOR P/N 159414-SPCL	10-11
FIGURE 5 - MK-212-6 TILE SAW P/N 167882	12-13
FIGURE 6 - MK-212-6 ASSY, MOTOR P/N 167882	14-15
FIGURE 7 - MK-212 ASSY, CUTTING HEAD P/N 159853	16-17
FIGURE 8 - MK-212-4 ASSY, SWITCH BOX P/N 172836-14	18
FIGURE 9 - MK-212-6 ASSY, SWITCH BOX P/N 172836-16	19
FIGURE 10 - WIRE DIAGRAM	20
FIGURE 11 - MK-212 ASSY, TABLE P/N 167762	21
FIGURE 12 - MK-212 ASSY, TABLE P/N 167762-MK	22
FIGURE 13 - MK-212-6, ASSY, TABLE P/N 168054	23
FIGURE 14 - MK-212-6, ASSY, TABLE P/N 168054-MK	24
FIGURE 15 - MK-212 ACCESSORY KIT P/N 160688	25

FIGURE 1 MK-212-4 TILE SAW P/N 159414

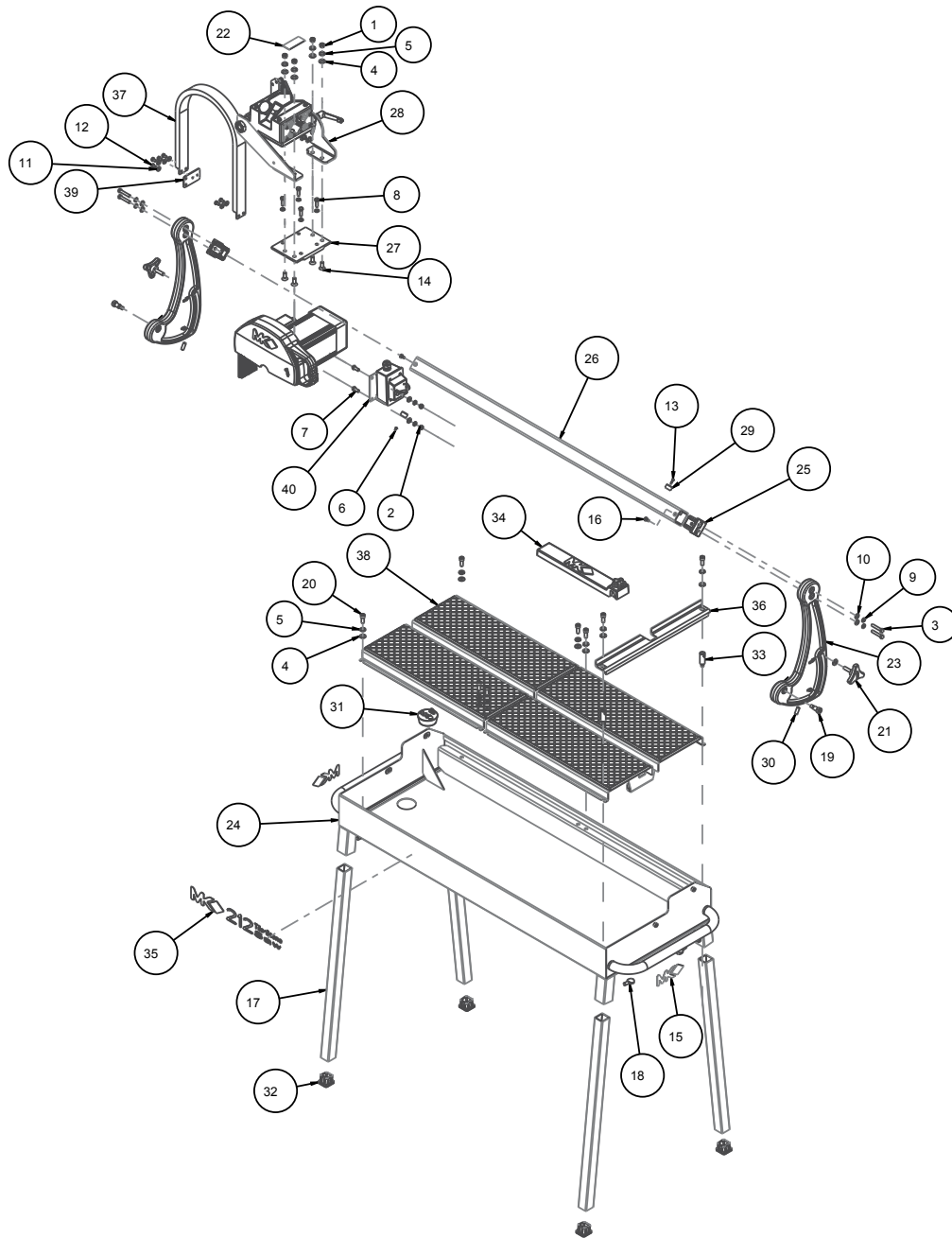

ITEM	DESCRIPTION	P/N	QTY.
1	NUT, 3/8-16 HEX	101188	4
2	NUT, HEX, 5/16 - 18	101196	2
3	SCREW, HEX HD, CAP, 5/16-18 X 1-3/4	150919	4
4	WASHER, 3/8 SAE FLAT	150923	14
5	WASHER, 3/8 SPLIT LOCK	150925	12

FIGURE 1 MK-212-4 TILE SAW P/N 159414

ITEM	DESCRIPTION	P/N	QTY.
6	SCREW, PAN HD SELF TPI0-24 X 3/8	151262	1
7	SCREW, HEX HD, CAP, 5/16-18 X 3/4	151369	2
8	SCREW, HEX HD, 5/16-18X1	151743	4
9	WASHER, LOCK, SPLIT, 5/16	151747	10
10	WASHER, FLAT, SAE, 5/16	151754	6
11	WASHER, FLAT, SAE, 1/4	151915	6
12	SCREW, 1/4-20X1/2 HEX HEAD	152608	6
13	SCREW, PHILP SELF TAP 10-24 X 5/8"	153681	1
14	SCREW, FLAT, HD, ALN, 3/8-16 X1	154019	4
15	LABEL, 1-3/4 X 5 MK LOGO	154335	2
16	SCREW, FLAT HD, 1/4-20X3/4	154657	4
17	LEG	155397	4
18	SCREW, THUMB 3/8-16 X 3/4"	155398	4
19	SCREW, SHLDR, SOC HD, 1/2X3/4	156177	2
20	SCREW, SOCKET HEAD CAP 3/8-16 X1	156602	8
21	KNOB, TRI PLASTIC MK-660 1-1/2	156770-02	2
22	TAG, SERIAL NUMBER, BLANK	157500-RW	1
23	POST, PIVOT COMP	159418	2
24	FRAME, PAN WELDMENT	159419	1
25	CASTING, RAIL BLOCK, MK-212-COM	159622	2
26	RAIL, 2 X 2 X 50	159641	1
27	MOUNT, SOGA MOTOR	159642	1
28	CUTTING HEAD	159853	1
29	STOP, RUBBER BUMPER	159855	2
30	SCREW, SET CUP, LOC, 3/8-16 X 1"	159856	2
31	PLUG, 2 1/2 DIA RUBBER	159858	1
32	FOOT, RUBBER	159977	4
33	STAND OFF, BACKSTOP	160117	2
34	ASSY, 15" RIP GUIDE	160288	1
35	LABEL, MK-212, TITLE	160669	2
36	STOP, BACK	165685	1
37	CARRIER, CABLE	167430	1
38	ASSY, TABLE, MK-212	167762	2
39	BRACKET, CABLE CARRIER, POST MNT	168048	1
40	ASSY, SWITCH BOX, 30A, 212	172836-14	1

FIGURE 2 MK-212-4 TILE SAW P/N 159414

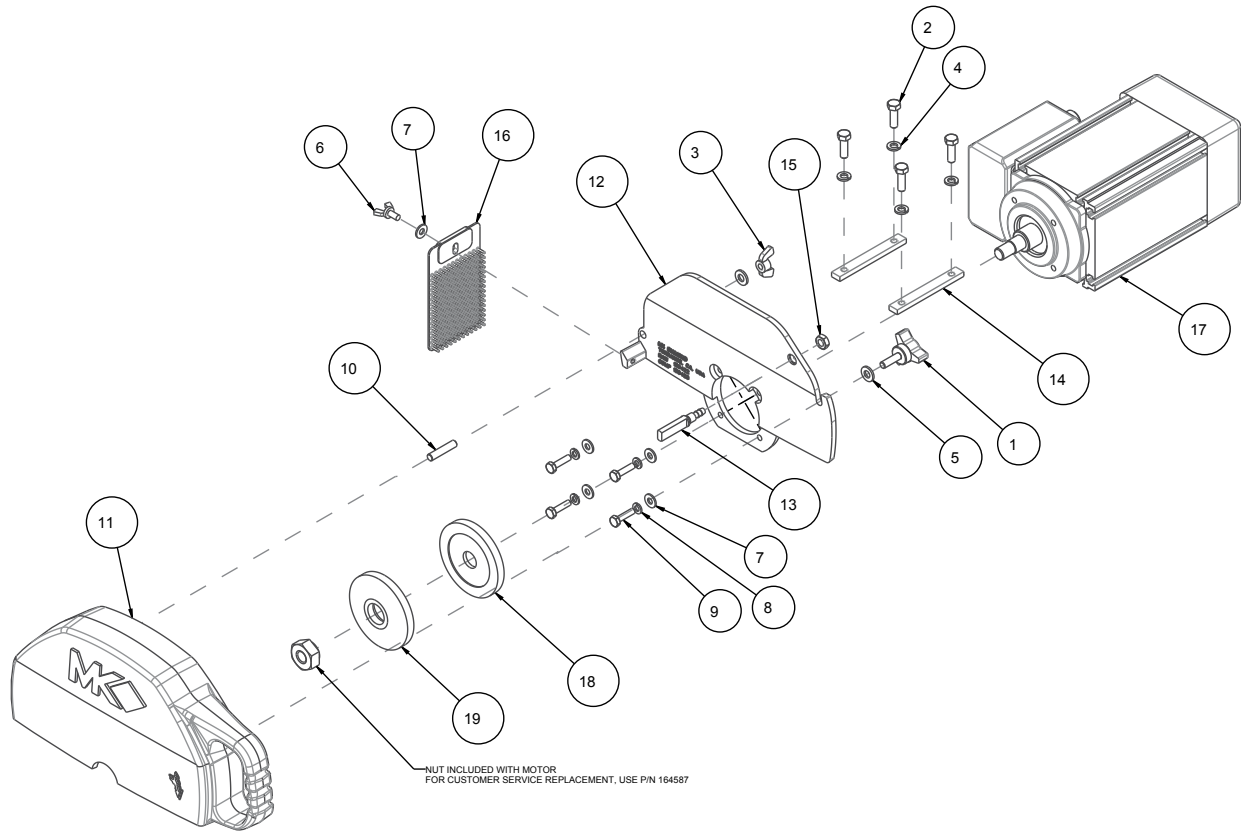
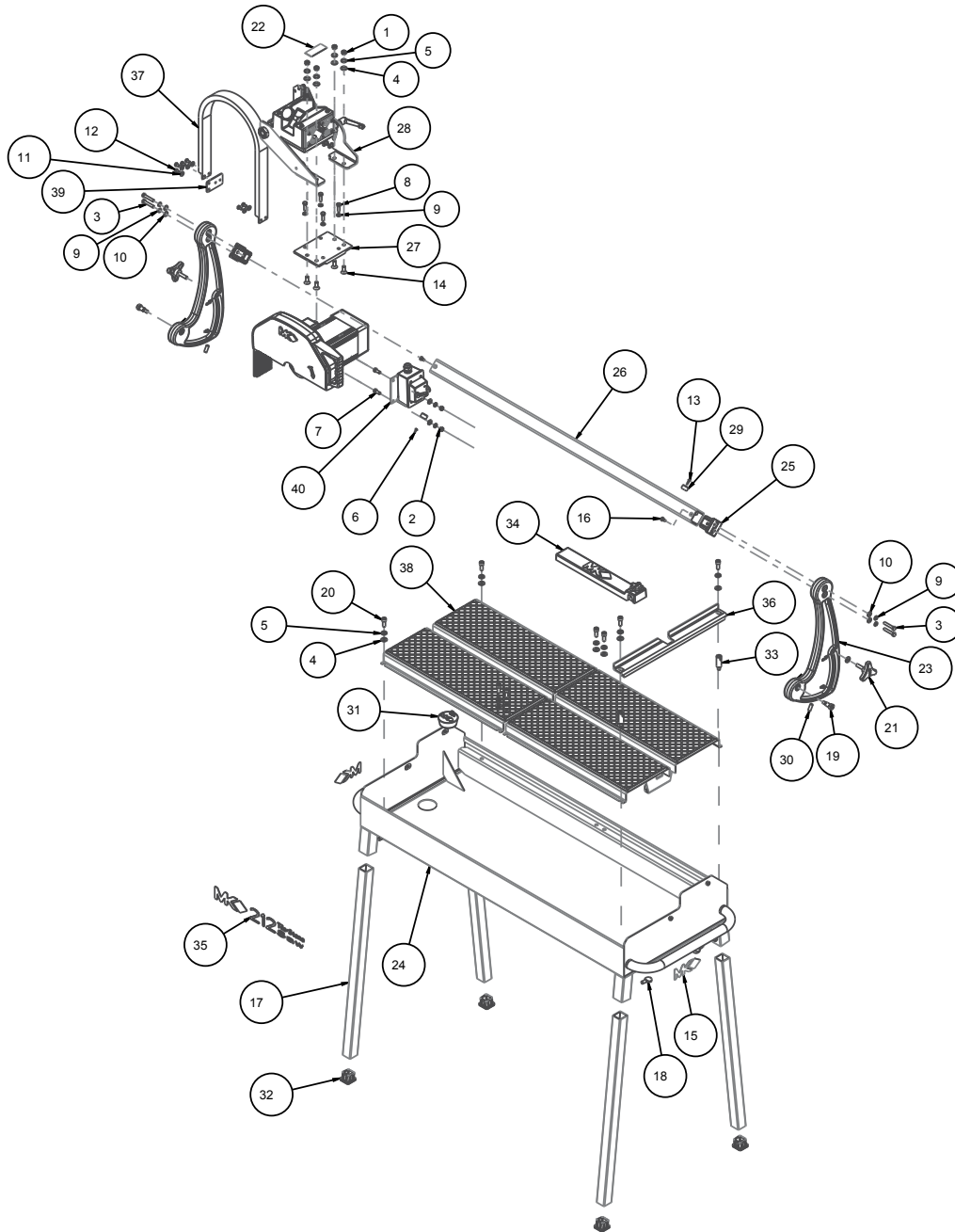

FIGURE 2 MK-212-4 TILE SAW P/N 159414

ITEM	DESCRIPTION	P/N	QTY.
1	KNOB, DAVIES, 5/16-18 X 1	151681	1
2	SCREW, HEX HD, 5/16 - 18 X 1	151743	4
3	NUT, WING, NYLK, 5/16-18	151746	1
4	WASHER, LOCK, SPLIT, 5/16	151747	4
5	WASHER, FLAT, SAE, 5/16	151754	2
6	SCREW, WING, 1/4-20X1/2	151888	1
7	WASHER, FLAT, SAE, 1/4	151915	5
8	WASHER, LOCK, SPLIT, 1/4	152591	4
9	SCREW, HEX HD, TAP, 1/4-20X1	152676	4
10	STUD, 5/16-18 X 1-1/2	153680	1
11	GUARD, BLADE -COMP	159416	1
12	GUARD, INNER BLADE (COMP)	159423	1
13	MANIFOLD, WATER	159854	1
14	KEY, MOTOR MOUNT	159859	2
15	NUT, 3/8-16 HEX	159863	1
16	GUARD, SPLASH	160310	1
17	2 H.P. SOGA 115V MOTOR	162078	1
18	FLANGE, BLADE, INNER, 10"	172647	1
19	FLANGE, BLADE, OUTER	172648	1

FIGURE 3 MK-212-4 TILE SAW WITH 12" CUTTING HEAD P/N 159414-SPCL



ITEM	DESCRIPTION	P/N	QTY.
1	NUT, 3/8-16 HEX	101188	4
2	NUT, HEX, 5/16 - 18	101196	2
3	SCREW, HEX HD, CAP, 5/16-18 X 1-3/4	150919	4
4	WASHER, 3/8 SAE FLAT	150923	14
5	WASHER, 3/8 SPLIT LOCK	150925	12
6	SCREW, PAN HD SELF TPI0-24 X 3/8	151262	1

FIGURE 3 MK-212-4 TILE SAW WITH 12" CUTTING HEAD P/N 159414-SPCL

ITEM	DESCRIPTION	P/N	QTY.
7	SCREW, HEX HD, CAP, 5/16-18 X 3/4	151369	2
8	SCREW, HEX HD, 5/16-18X1	151743	4
9	WASHER, LOCK, SPLIT, 5/16	151747	10
10	WASHER, FLAT, SAE, 5/16	151754	6
11	WASHER FLAT SAE, 1/4	151915	6
12	SCREW, 1/4-20 X 1/2 HEX HEAD	152608	6
13	SCREW, PHILP SELF TAP 10-24 X 5/8"	153681	1
14	SCREW, FLAT, HD, ALN, 3/8-16 X1	154019	4
15	LABEL, 1-3/4 X 5 MK LOGO	154335	2
16	SCREW, FLAT HD, 1/4-20X3/4	154657	4
17	LEG	155397	4
18	SCREW, THUMB 3/8-16 X 3/4"	155398	4
19	SCREW, SHLDR, SOC HD, 1/2X3/4	156177	2
20	SCREW, SOCKET HEAD CAP 3/8-16 X1	156602	8
21	KNOB, TRI PLASTIC MK-660 1-1/2	156770-02	2
22	TAG, SERIAL NUMBER, BLANK	157500-RW	1
23	POST, PIVOT (COMP)	159418	2
24	FRAME, PAN WELDMENT, SPCL	159419-SPCL	1
25	CASTING, RAIL BLOCK, MK-212-COM	159622	2
26	RAIL, 2 X 2 X 50	159641	1
27	MOUNT, SOGA MOTOR	159642	1
28	CUTTING HEAD	159853	1
29	STOP, RUBBER BUMPER	159855	2
30	SCREW, SET CUP 3/8-16 X 1"	159856	2
31	PLUG, 2 1/2 DIA RUBBER	159858	1
32	FOOT, RUBBER	159977	4
33	STAND OFF, BACKSTOP	160117	2
34	ASSY, 15" RIP GUIDE	160288	1
35	LABEL, MK-212, TITLE	160669	2
36	STOP, BACK	165685	1
37	CARRIER, CABLE	167430	1
38	ASSY, TABLE, MK-212	167762	2
39	BRACKET, CABLE CARRIER, POST MNT	168048	1
40	ASSY, SWITCH BOX, 30A, 212	172836-14	1

FIGURE 4 MK-212-4 TILE SAW WITH 12" CUTTING HEAD P/N 159414-SPCL

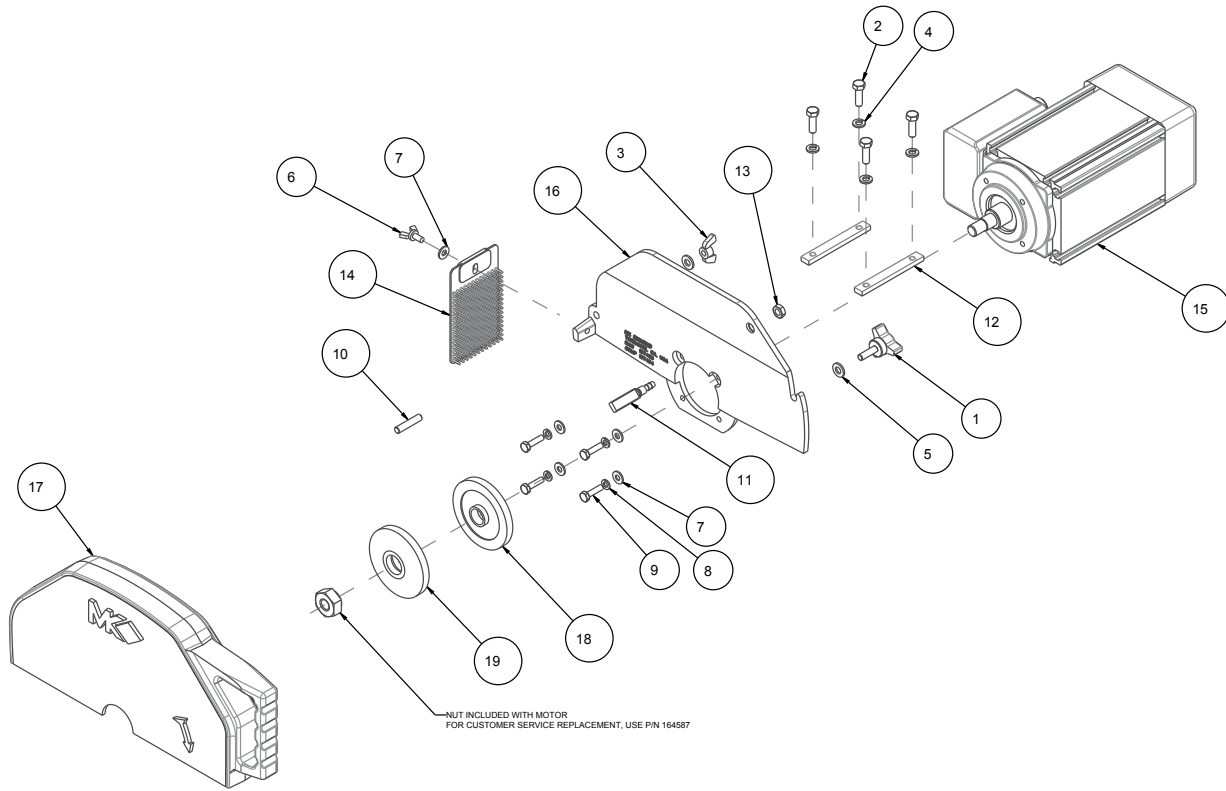
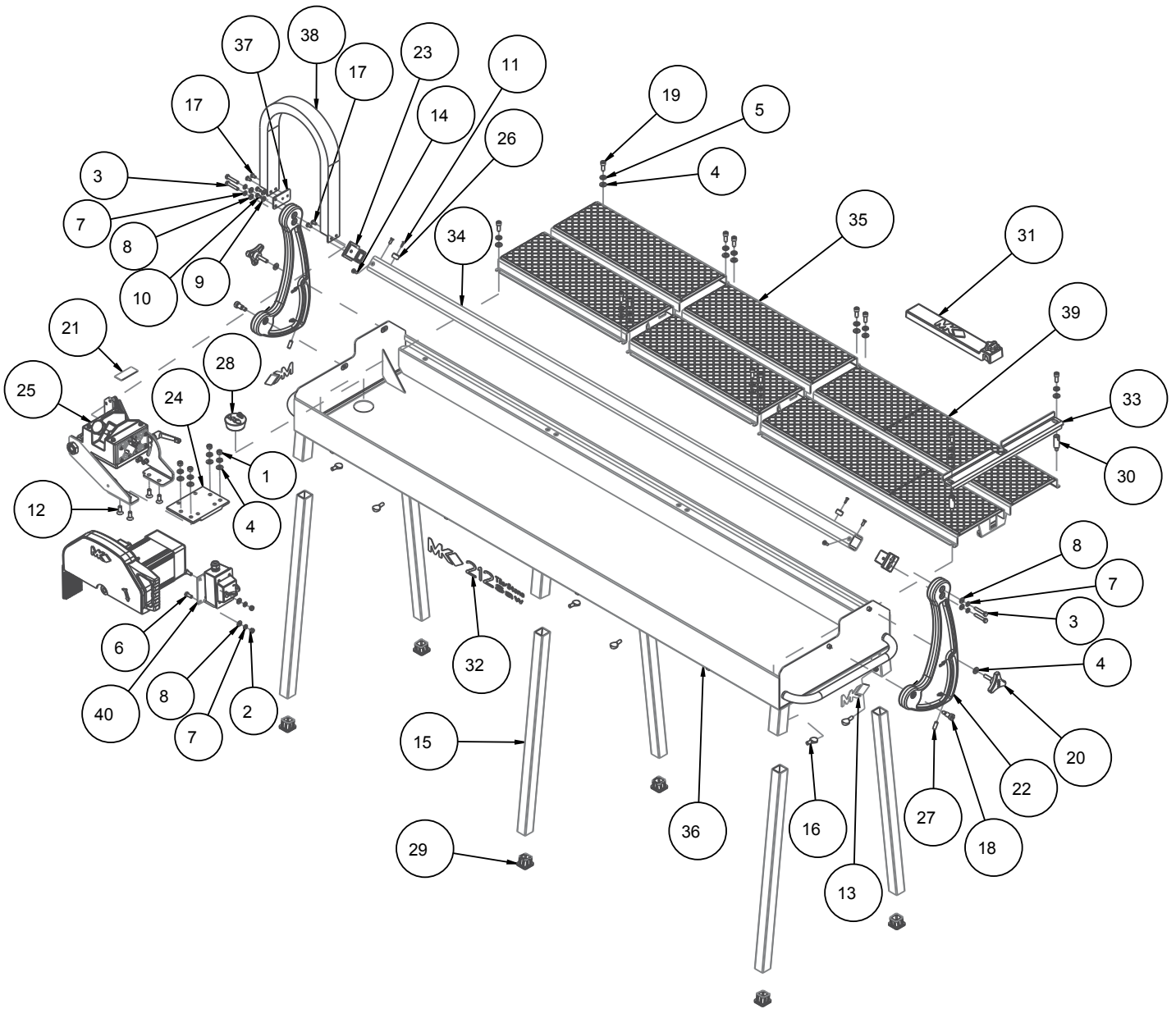

FIGURE 4 MK-212-4 TILE SAW WITH 12" CUTTING HEAD P/N 159414-SPCL

ITEM	DESCRIPTION	P/N	QTY.
1	KNOB, DAVIES, 5/16-18 X 1	151681	1
2	SCREW, HEX HD, 5/16-18 X 1	151743	4
3	NUT, WING, NYLK, 5/16-18	151746	1
4	WASHER, LOCK SPLIT, 5/16	151747	4
5	WASHER, FLAT, SAE, 5/16	151754	2
6	SCREW, WING, 1/4-20X1/2	151888	1
7	WASHER, FLAT, SAE, 1/4	151915	5
8	WASHER, LOCK, SPLIT, 1/4	152591	4
9	SCREW, HEX HD, TAP, 1/4-20X1	152676	4
10	STUD, 5/16-18 X 1-1/2"	153680	1
11	MANIFOLD, WATER	159854	1
12	KEY, MOTOR MOUNT	159859	2
13	NUT, 3/8-16 HEX	159863	1
14	GUARD, SPLASH	160310	1
15	MOTOR, 115V, 2HP SOGA	162078	1
16	GUARD, BLADE INNER - COMP	167494	1
17	GUARD, BLADE, OUTER-COMP	167496	1
18	FLANGE, BLADE, INNER, 12"	167539	1
19	FLANGE, BLADE OUTER	172648	1

FIGURE 5 MK-212-6 TILE SAW P/N 167882



ITEM	DESCRIPTION	P/N	QTY.
1	NUT, HEX 3/8-16	101188	4
2	NUT, HEX, 5/16 - 18	101196	2
3	SCREW, HEX HD, CAP, 5/16-18 X 1-3/4	150919	4
4	WASHER, 3/8 SAE FLAT	150923	18
5	WASHER, 3/8 SPLIT LOCK	150925	16

FIGURE 5 MK-212-6 TILE SAW P/N 167882

ITEM	DESCRIPTION	P/N	QTY.
6	SCREW, HEX HD, CAP, 5/16-18 X 3/4	151369	2
7	WASHER, LOCK, SPLIT, 5/16	151747	6
8	WASHER, FLAT, SAE, 5/16	151754	6
9	WASHER, FLAT, SAE, 1/4	151915	2
10	SCREW, 1/4-20 X 1/2 HEX HEAD	152608	2
11	SCREW, PHILP SELF TAP 10-24 X 5/8"	153681	2
12	SCREW, FLAT, HD, ALN, 3/8-16 X1	154019	4
13	LABEL, 1-3/4 X 5 MK LOGO	154335	2
14	SCREW, FLAT HD, 1/4-20X3/4	154657	4
15	LEG	155397	6
16	SCREW, THUMB 3/8-16 X 3/4"	155398	6
17	SCREW, PAN HD, CAP, 1/4-20 X 1/2	155452	4
18	SCREW, SHLDR, SOC HD, 1/2X3/4	156177	2
19	SCREW, SOCKET HEAD CAP 3/8-16 X1	156602	12
20	KNOB, TRI PLASTIC MK-660 1-1/2	156770-02	2
21	TAG, SERIAL NUMBER, BLANK	157500-RW	1
22	POST, PIVOT (COMP)	159418	2
23	RAIL BLOCK, MK-212-72 MOD	159622-MOD	2
24	MOUNT, SOGA MOTOR	159642	1
25	CUTTING HEAD	159853	1
26	STOP, RUBBER BUMPER	159855	2
27	SCREW, SET CUP 3/8-16 X 1"	159856	2
28	PLUG, 2 1/2 DIA RUBBER	159858	1
29	FOOT, RUBBER	159977	6
30	STAND OFF, BACKSTOP	160117	2
31	ASSY, 15" RIP GUIDE	160288	1
32	LABEL, MK-212, TITLE	160669	2
33	STOP, BACK	165685	1
34	RAIL	166887	1
35	ASSY, TABLE, MK-212	167762	2
36	FRAME, PAN	167883	1
37	BRACKET, CABLE CARRIER, POST MNT	168048	1
38	CARRIER, CABLE	168051	1
39	ASSY, TABLE, MK-212-6	168054	1
40	ASSY, SWITCH BOX, 30A, 212-6	172836-16	1

FIGURE 6 MK-212-6 TILE SAW P/N 167882

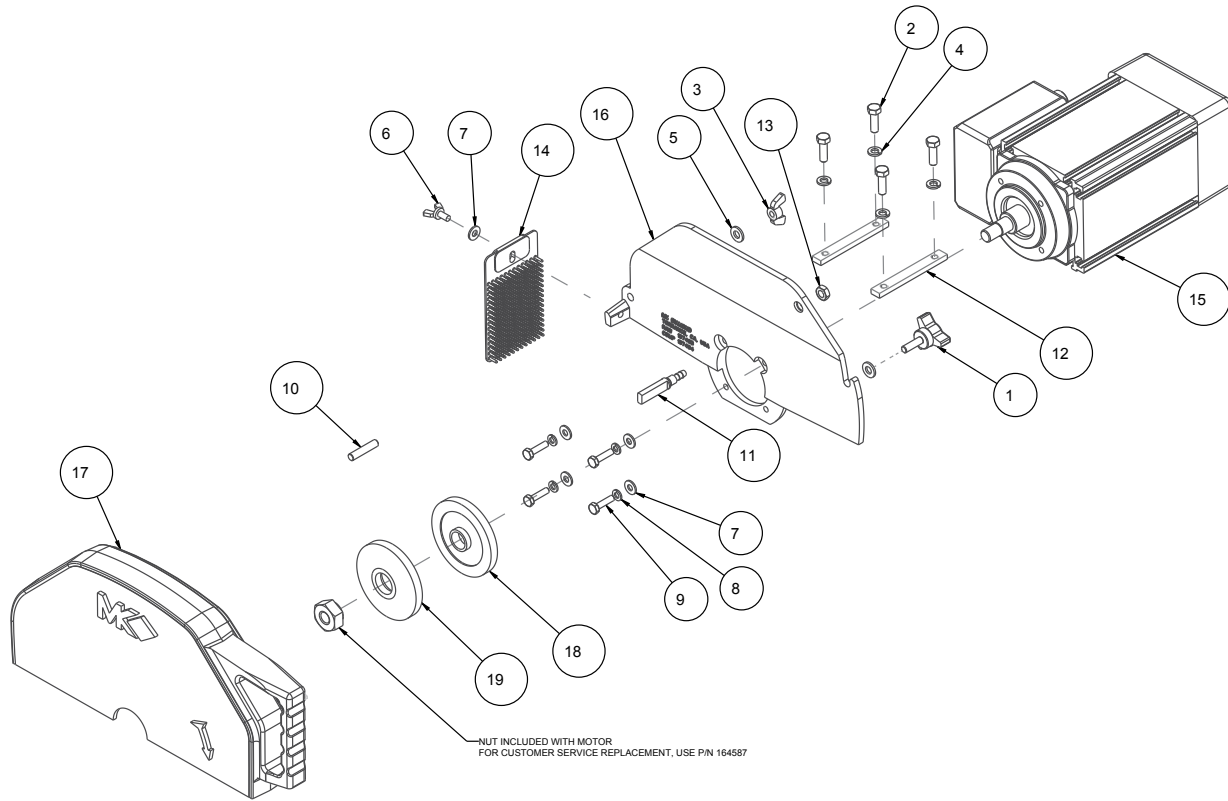

FIGURE 6 MK-212-6 TILE SAW P/N 167882

ITEM	DESCRIPTION	P/N	QTY.
1	KNOB, DAVIES, 5/16-18 X 1	151681	1
2	SCREW, HEX HD, 5/16-18X1	151743	4
3	NUT, WING, NYLK, 5/16-18	151746	1
4	WASHER, LOCK, SPLIT, 5/16	151747	4
5	WASHER, FLAT, SAE, 5/16	151754	2
6	SCREW, WING, 1/4-20X1/2	151888	1
7	WASHER, FLAT, SAE, 1/4	151915	5
8	WASHER, LOCK, SPLIT, 1/4	152591	4
9	SCREW, HEX HD, TAP, 1/4-20X1	152676	4
10	STUD, 5/16-18 X 1-1/2	153680	1
11	MANIFOLD, WATER	159854	1
12	KEY, MOTOR MOUNT	159859	2
13	NUT, 3/8-16 HEX	159863	1
14	GUARD, SPLASH	160310	1
15	MOTOR, 115V, 2HP SOGA	162078	1
16	GUARD, BLADE INNER - COMP	167494	1
17	GUARD, BLADE OUTER - COMP	167496	1
18	FLANGE, BLADE INNER 12"	167539	1
19	FLANGE, BLADE, OUTER	172648	1

FIGURE 7 MK-212 TILE/STONE SAW CUTTING HEAD P/N 159853

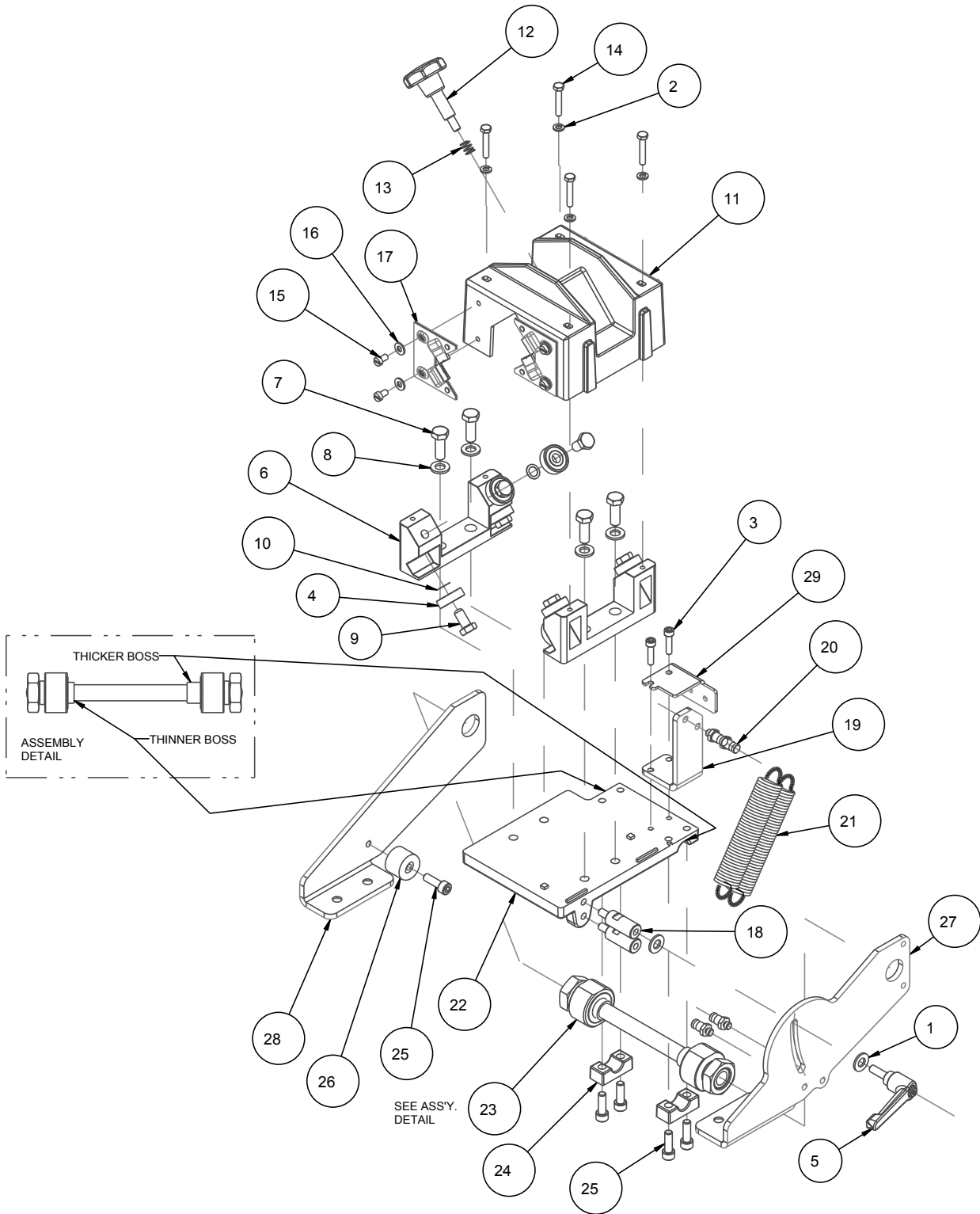
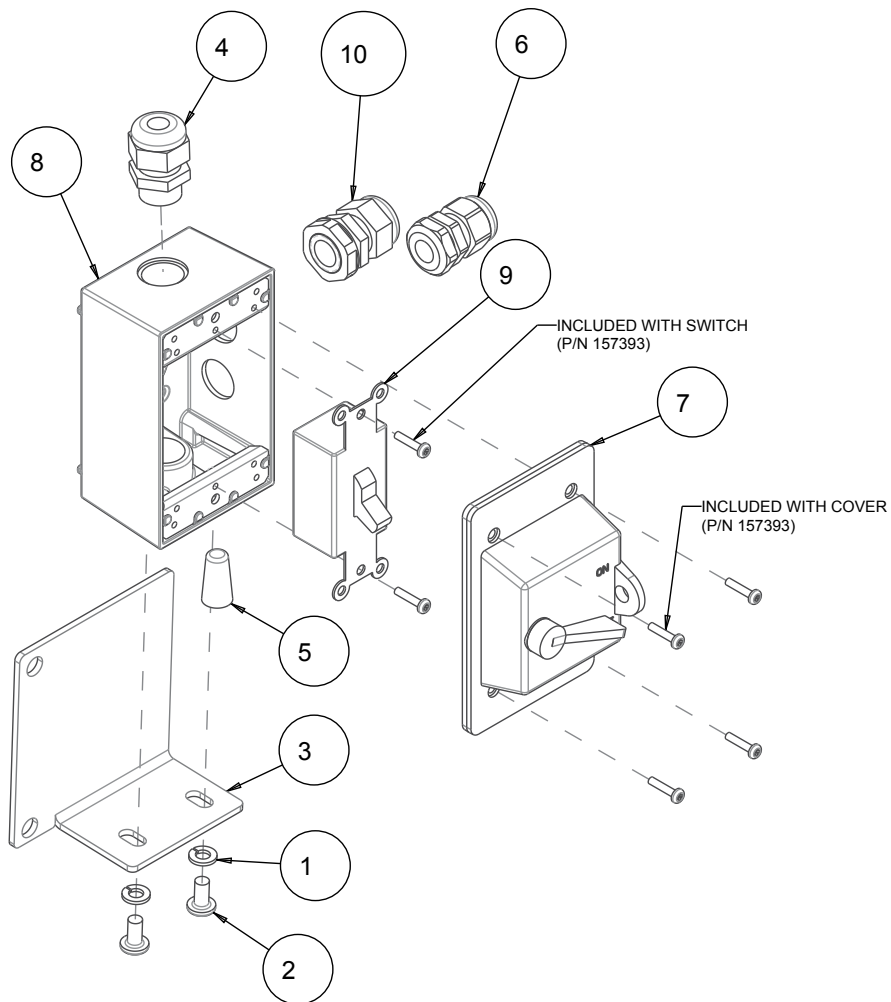

FIGURE 7 MK-212 TILE/STONE SAW CUTTING HEAD P/N 159853

ITEM	DESCRIPTION	P/N	QTY.
1	WASHER, 3/8 SAE FLAT	150923	2
2	WASHER, LOCK, SPLIT, M6	158159	4
3	SCREW, SOC HD, CAP, M6X25MM	158268	2
4	BEARING, BALL, DEEP GROOVE	160097	8
5	KNOB, ADJUSTMENT	160184	1
6	BLOCK, BEARING RAIL (COMP)	160201	2
7	SCREW, HEX HEAD M10-1.5 X 30MM	160202	4
8	WASHER, FLAT, N, M10	160203	4
9	SCREW, HEX HEAD CAP M10 X20MM	160204	8
10	SHIM, 3/8 X 5/8 X .008 STEEL	160205	8
11	CASTING, COVER, BEARING COMP	160207	1
12	KNOB, LOCKING	160210	1
13	SPRING, COMPRESSION	160211	1
14	SCREW, HEX HEAD CAP, M6 X 30MM	160212	4
15	SCREW, PAN HEAD SLOT M6 X 10MM	160214	8
16	WASHER, FLAT M6	160215	8
17	ASSEMBLY, WIPER, MK-212	160216	4
18	STAND-OFF, BEARING SUPPORT BASE	160218	2
19	BRACKET, SPRING SUPPORT	160220	1
20	PIN, SPRING SUPPORT	160221	4
21	SPRING	160222	2
22	BASE, BEARING SUPPORT	160223	1
23	ASSY, CUTTING HEAD PIVOT AXLE	160224	1
24	CLAMP, PIVOT AXLE	160226	2
25	SCREW, SOCKET HEAD CAP M8 X 25MM	160227	5
26	STOP, RUBBER BUMPER	160228	1
27	ARM, MK-212 SWING (LEFT)	160238	1
28	ARM, MK-212 SWING (RIGHT)	160242	1
29	BRACKET, CABLE CARRIER, HD MNT	171877	1

FIGURE 8 MK-212-6 ASSY, SWITCH BOX 30V MK-212-4 P/N 172836-14



ITEM	DESCRIPTION	P/N	QTY.
1	WASHER, LOCK, SPLIT, 1/4	152591	2
2	SCREW, PAN HD, CAP, 1/4-20 X 1/2	155452	2
3	BRACKET, SWITCH MK-212	159864	1
4	CORD, MOTOR, 14/3 SJTW	159907	1
5	WIRE NUT 4#16 (YELLOW)	159968	1
6	CORD, PUMP, 16/3 SJTW, 120V	167302-4	1
7	COVER, 30A SWITCH, PLAS	171264-P	1
8	BOX, SWITCH, COMP MK-212	172835-1	1
9	SWITCH, 30A 120/240-277V 2HP	172840	1
10	CORD, POWER, MK-212 120V	172866	1

FIGURE 9 MK-212-6 ASSY, SWITCH BOX 30V MK-212-6 P/N 172836-16

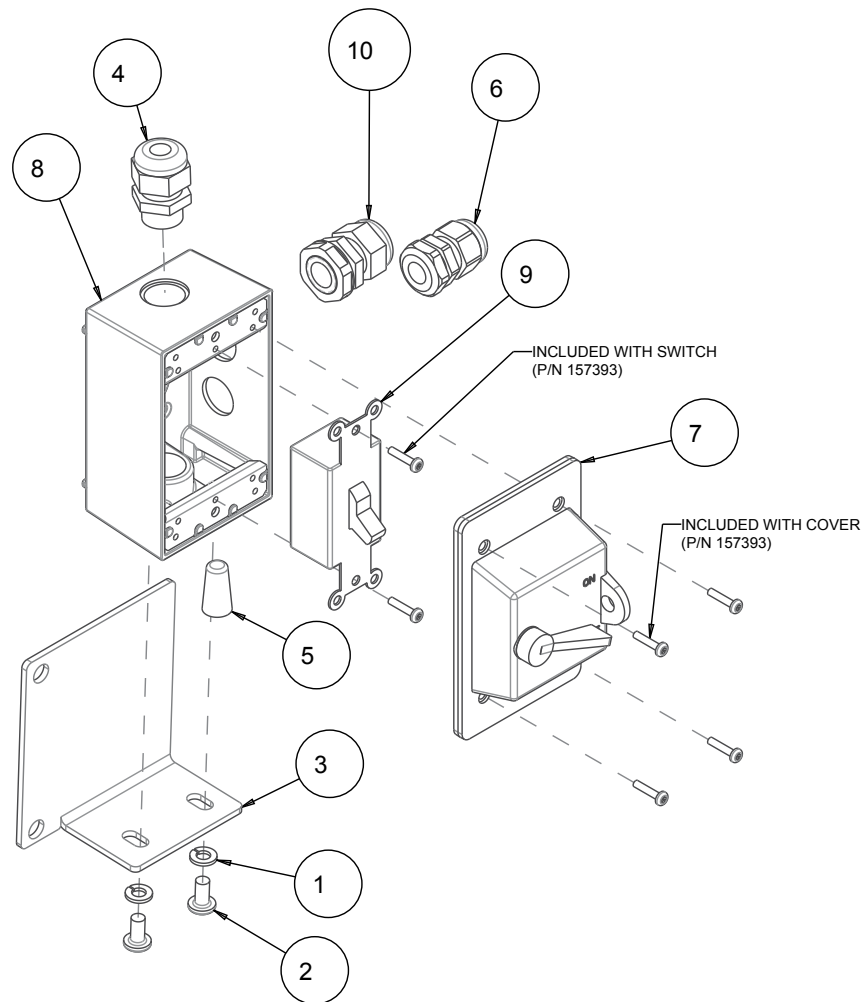

ITEM	DESCRIPTION	P/N	QTY.
1	WASHER, LOCK, SPLIT, 1/4	152591	2
2	SCREW, PAN HD, CAP, 1/4-20 X 1/2	155452	2
3	BRACKET, SWITCH MK-212	159864	1
4	CORD, MOTOR, 14/3 SJTW	159907	1
5	WIRE NUT 4#16 (YELLOW)	159968	1
6	CORD, PUMP, 16/3 SJTW, 120V	167302	1
7	COVER, 30A SWITCH, PLAS	171264-P	1
8	BOX, SWITCH, COMP MK-212	172835-1	1
9	SWITCH, 30A 120/240-277V 2HP	172840	1
10	CORD, POWER, MK-212 120V	172866	1

FIGURE 10 WIRE DIAGRAM

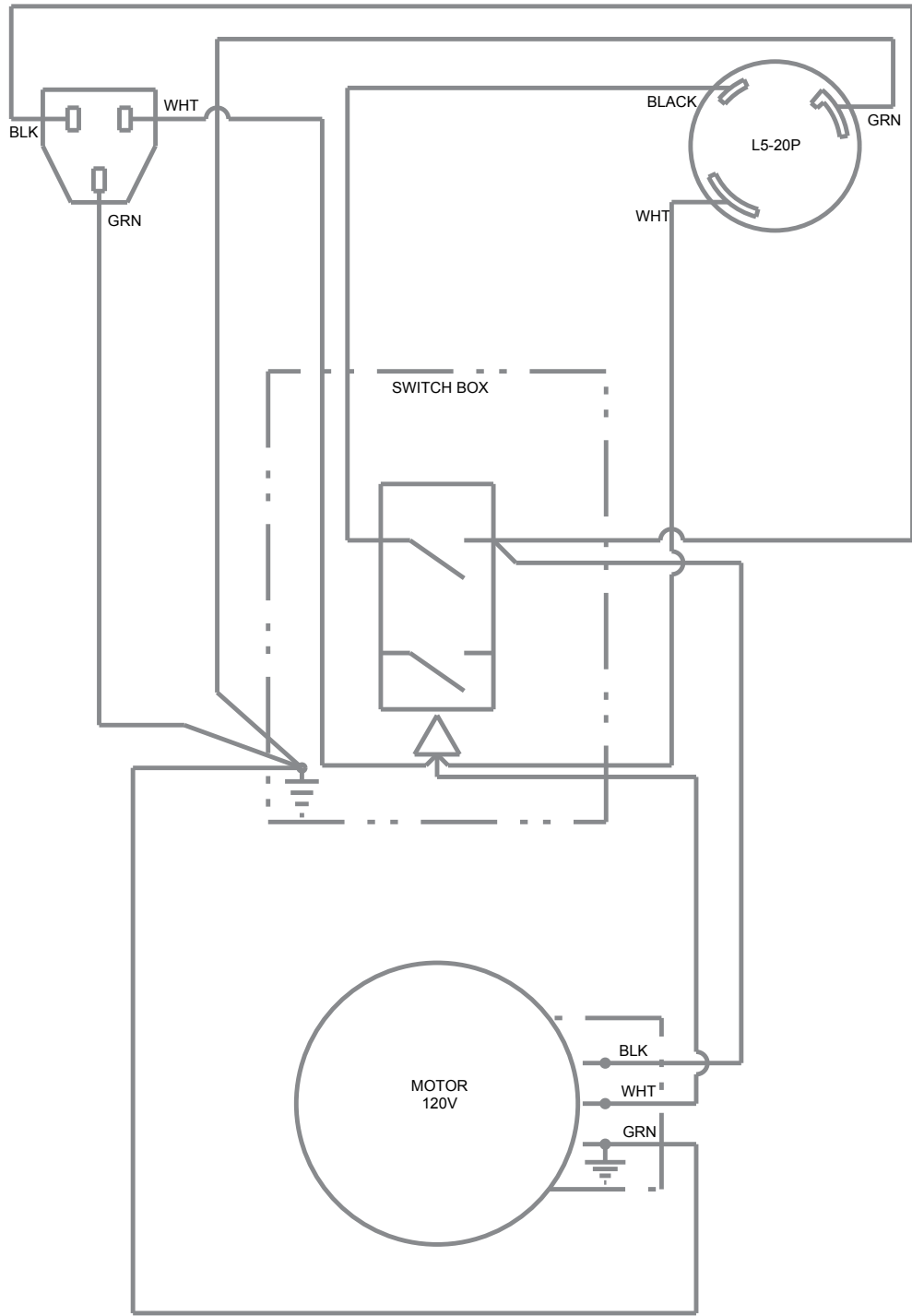
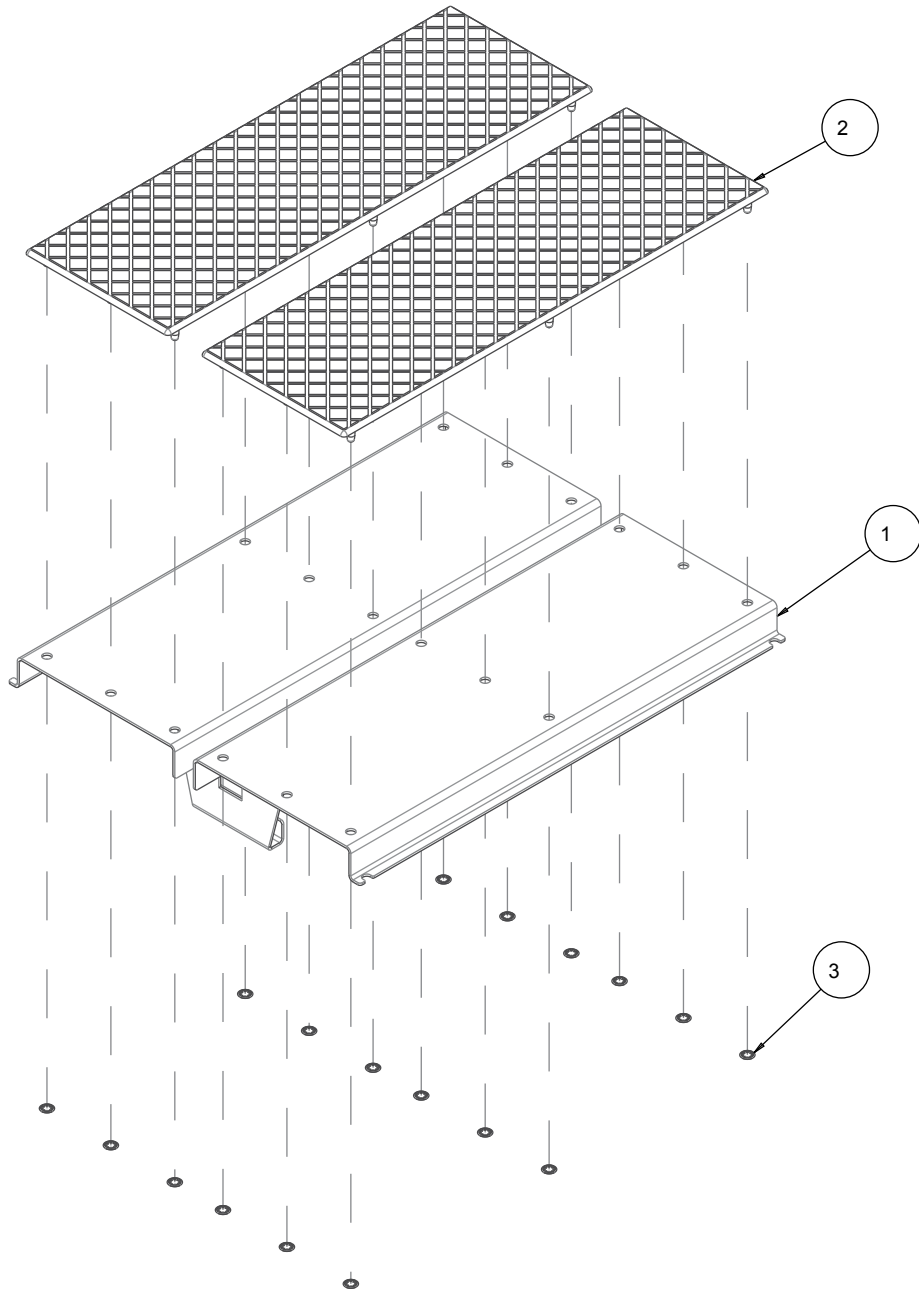
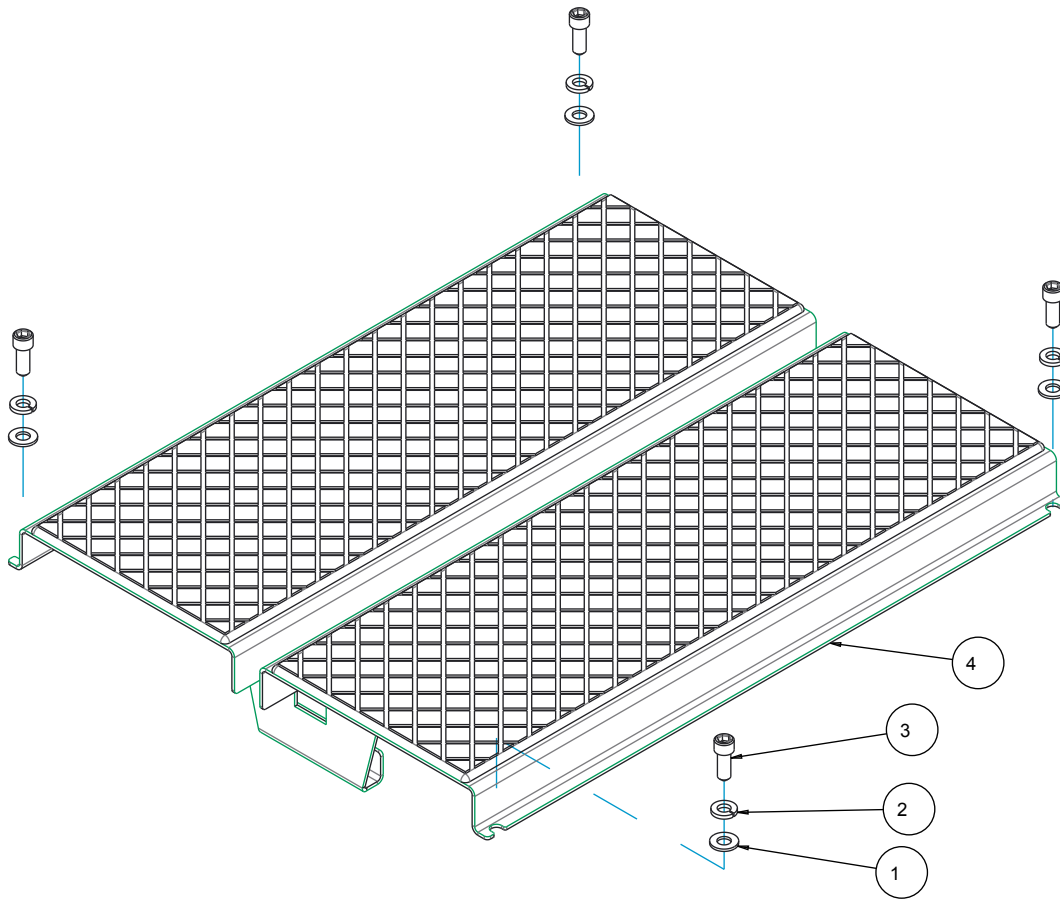

FIGURE 11 MK-212 ASSY, TABLE, MK-212 P/N 167762



ITEM	DESCRIPTION	P/N	QTY.
1	TABLE	159420	1
2	MAT, TABLE, MK-212	166418	2
3	RING, RETAINING, 5/16 SHAFT	171878	18

FIGURE 12 MK-212 ASSY, TABLE, MK-212 P/N 167762-MK



ITEM	DESCRIPTION	P/N	QTY.
1	WASHER, FLAT, SAE, 3/8	150923	4
2	WASHER, LOCK, SPLIT, 3/8	150925	4
3	SCREW, SOCKET HEAD CAP 3/8-16 X 1	156602	4
4	ASSY, TABLE, MK-212	167762	1

FIGURE 13 MK-212 ASSY, TABLE, MK-212 P/N 168054

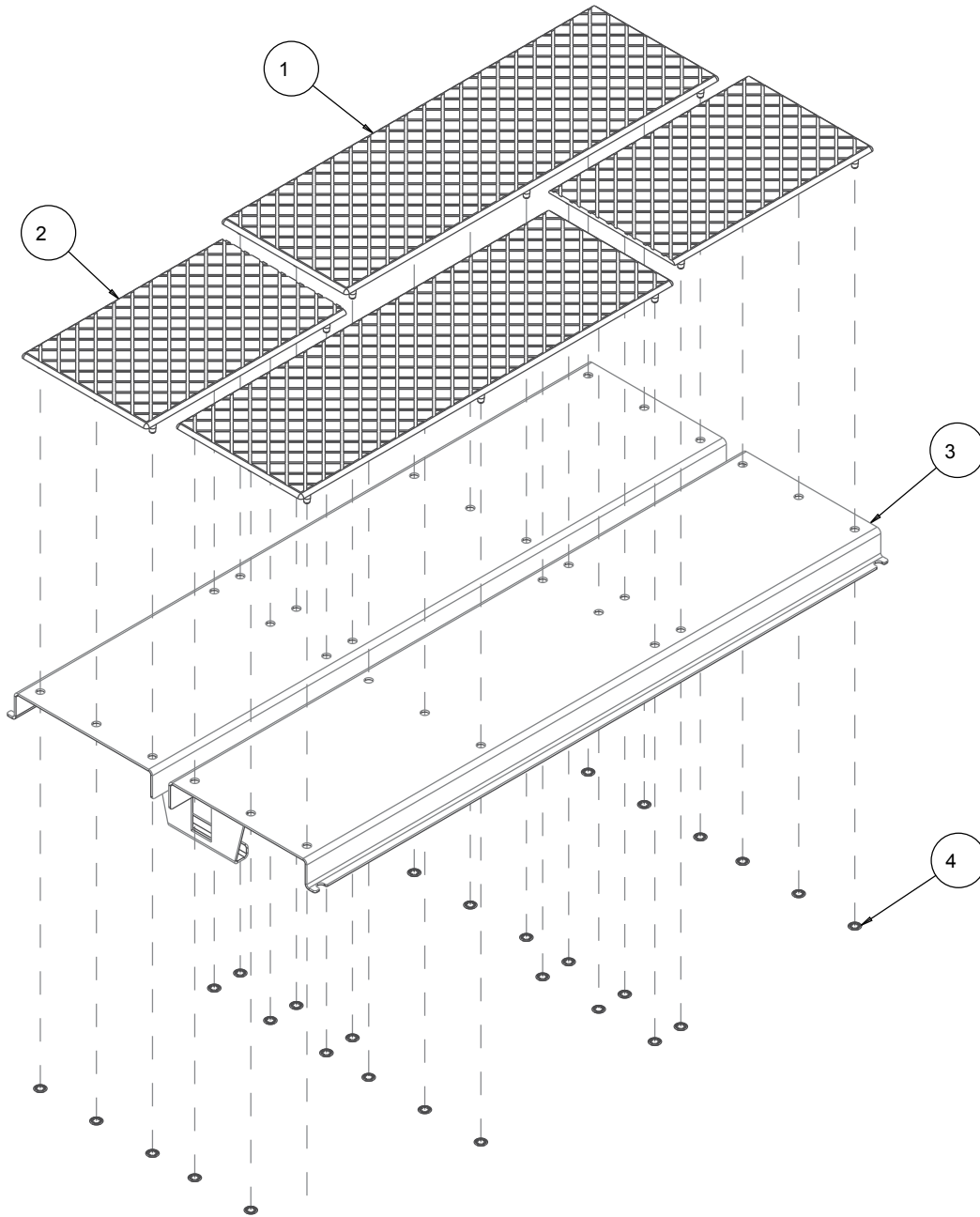

ITEM	DESCRIPTION	P/N	QTY.
1	MAT, TABLE, MK-212	166418	2
2	MAT, TABLE, MK-212-6, MOD	166890	2
3	TABLE, MK-212-6	167937	1
4	RING, RETAINING, 5/16 SHAFT	171878	30

FIGURE 14 MK-212-6, ASSY, TABLE P/N 168054-MK

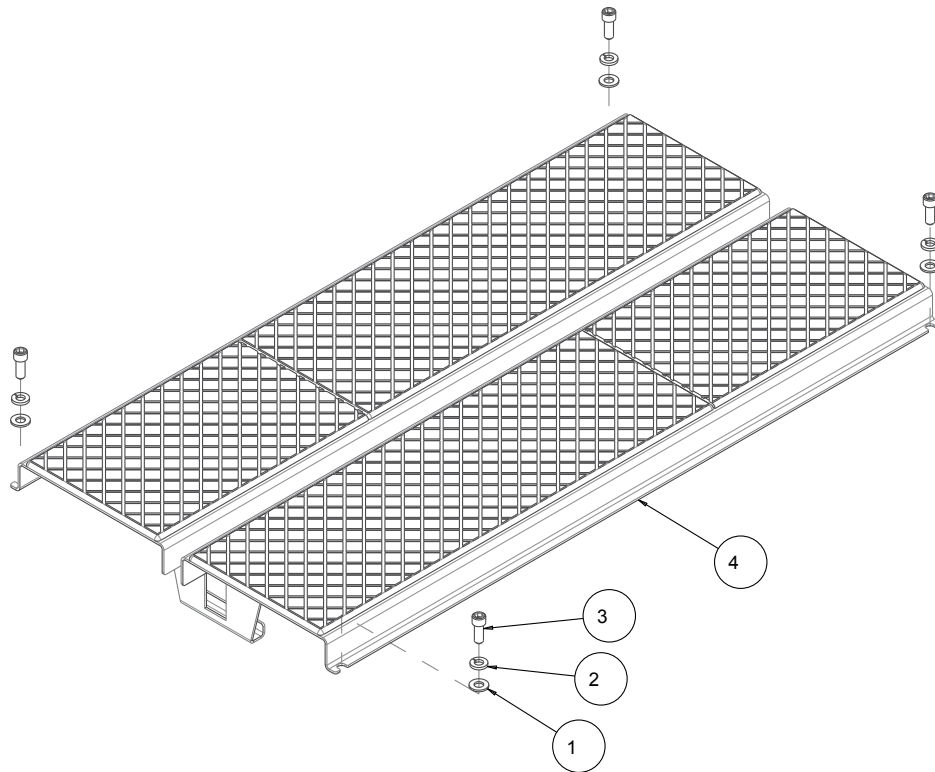

ITEM	DESCRIPTION	P/N	QTY.
1	WASHER, FLAT, SAE, 3/8	150923	4
2	WASHER, LOCK, SPLIT, 3/8	150925	4
3	SCREW, SOCKET HEAD CAP 3/8-16 X 1	156602	4
4	ASSY, TABLE, MK-212-6	168054	1

FIGURE 15 MK-212 ACCESSORY KIT, MK-212 P/N 160688

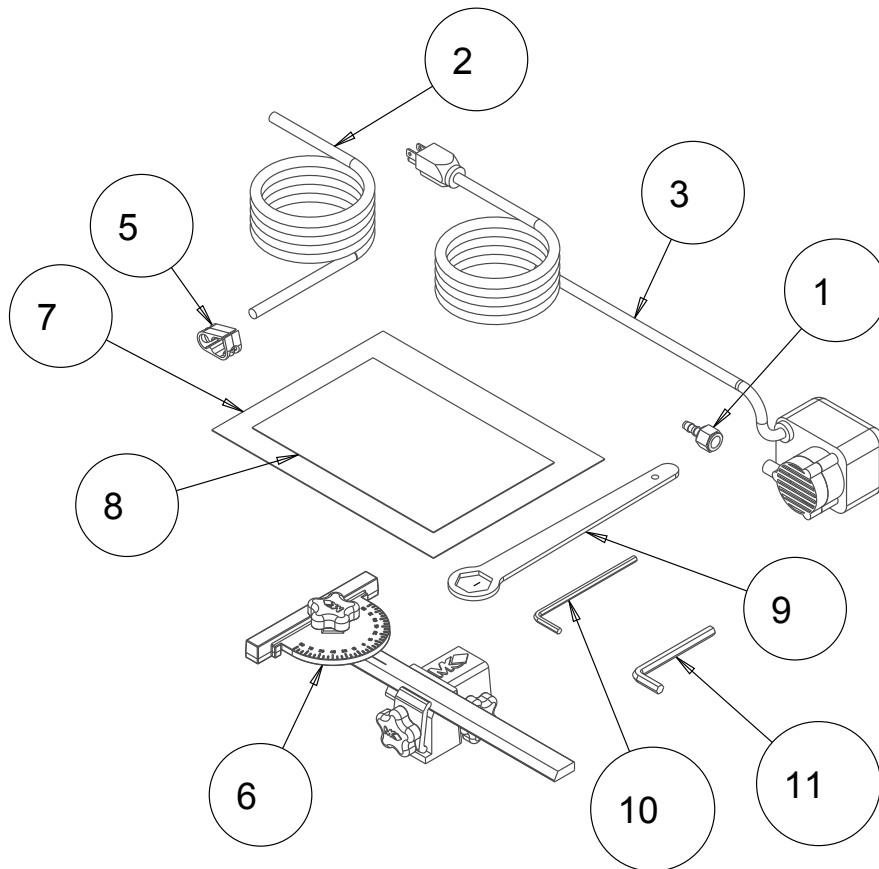

ITEM	DESCRIPTION	P/N	QTY.
1	ADAPTER, PUMP TPF-22 1/4 X 1/4	128397	1
2	HOSE, VINYL, 1/4X 3/8 (6.0')	132951	1
3	PUMP, WATER 115V/60HZ UL/CSA	151271	1
4	CARTON, #13 SHIPPING (8" & 10)	153738	1
5	CLAMP, HOSE, 1/4-1/2 FLOW	154394	1
6	PROTRACTOR ASSEMBLY	159572	1
7	OWNER'S MANUAL, MK-212	159862	1
8	PARTS MANUAL, MK-212	159862-PM	1
9	WRENCH, BOX END, 30MM	159978	1
10	WRENCH, 5MM ALLEN	159979	1
11	WRENCH, 5/16" ALLEN	167679	1