

# Warranty

## CANOGA® EQUIPMENT



MANUFACTURED BY:

MK DIAMOND PRODUCTS, INC.

1315 Storm Parkway

Torrance, CA 90501

Telephone (310) 539-5221 Fax (310) 539-5158

### LIMITED WARRANTY

MK DIAMOND PRODUCTS, INC. will guarantee every CANOGA® machine they build, to be free from defects in material and workmanship for (1) one year from date of purchase.

The obligation of MK DIAMOND PRODUCTS, INC. under this warranty is limited to the repair or replacement of any parts which, under normal use, prove to be defective in material or workmanship. The parts involved or the unit in question should be returned to MK DIAMOND PRODUCTS, INC. or to a point designated by us, transportation prepaid.

This warranty does not obligate us to bear the cost of labor or transportation charges in connection with replacement or repair of defective parts. Likewise, it shall NOT apply to any unit which has been subjected to misuse, neglect or accident. This warranty does NOT apply to any machine which has been repaired or altered outside our factory.

This warranty does NOT obligate MK DIAMOND PRODUCTS, INC. with respect to items not of our manufacture, such as engines, motors, hydraulics, etc., which are subject to their own guarantees and warranties.

We shall in no event be liable for consequential damages or contingent liabilities arising out of failure of any equipment or parts to operate properly.

## CANOGA® EQUIPMENT

MANUFACTURED BY:

MK DIAMOND PRODUCTS, INC.

1315 Storm Parkway

Torrance, CA 90501

Telephone (310) 539-5221 Fax (310) 539-5158

CANOGA® Equipment Model 100

# CANOGA® CONCRETE MIXER

## OWNERS/PARTS MANUAL 100 Series Machines

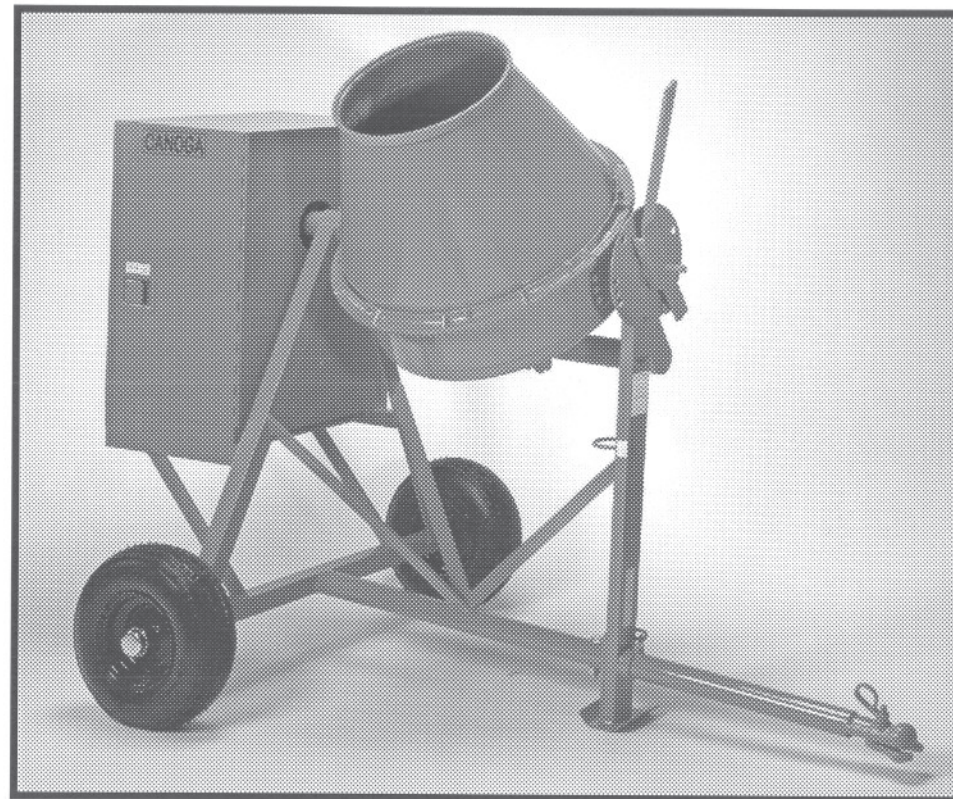

## CANOGA® EQUIPMENT

MANUFACTURED BY:

MK DIAMOND PRODUCTS, INC.

1315 Storm Parkway

Torrance, CA 90501

www.canogamixers.com

CANOGA® Equipment Model 100

## CONGRATULATIONS

You have just purchased the finest machine of its type available. If you follow the maintenance instructions contained in this manual, your machine will last a very long time. Preventative maintenance is always cheaper than unscheduled maintenance where work crews are idled due to the lack of an operating mixer.

## SAFETY INSTRUCTIONS

1. DO NOT operate the mixer before reading the Owners Instruction Manual. Injury can occur from careless use of this equipment.
2. Keep unauthorized and inexperienced people away from the mixer at all times. Children should never be allowed near the mixer.
3. Block the wheels of the mixer when parked on a slope.
4. NEVER reach into the drum opening with hands or foreign objects when the mixer is in operation.
5. Maintain equipment regularly to keep it in a safe operating condition. ALWAYS STOP THE ENGINE DURING MAINTENANCE. Caution must be exercised while servicing this equipment. Rotating blades and moving parts can cause injury if contacted.
6. The engine compartment door should always be closed while the mixer is being used. Dust and sand can damage the engine, belts and gears.
7. DO NOT add fuel or oil without first stopping the engine.
8. STOP THE ENGINE when leaving the equipment. Never leave the mixer unattended when it is in operation.
9. Periodically check all bolts and fasteners on the mixer for tightness and condition. The vibration from the motor when it is in operation could loosen nuts and bolts.
10. Be certain that the safety chain is securely attached before towing the mixer. Be certain that the tow bar bolt and lock nut are secure and in good condition.
11. All warranties are VOID if any unauthorized modifications are made to this equipment.

**DON'T TAKE CHANCES! DON'T BE CARELESS! DON'T CAUSE INJURY!**

**ALWAYS PRACTICE SAFETY**

CANOGA® Equipment Model 100

## Other Equipment Manufactured By Southeast Construction Products, Inc. Under The "CANOGA®" Trademark

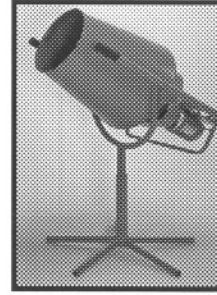

MODEL 80

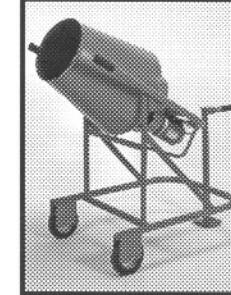

MODEL 90



MODEL 95

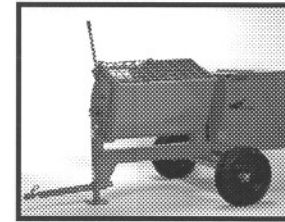

MODEL 1295

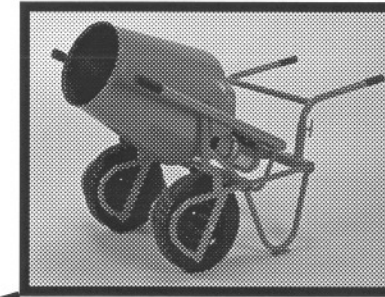

MODEL 70

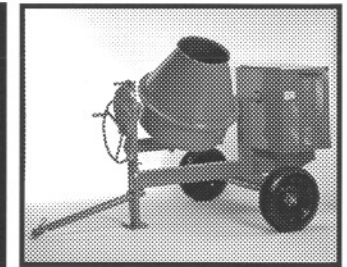

MODEL 300

*Detach the  
Dump by pivoting Dump like a  
on the frame. wheel barrow! frame from the  
Use the frame to  
move material.*

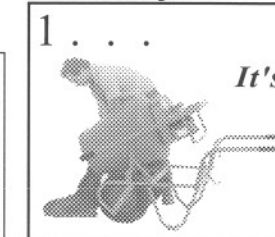

*It's so easy!*

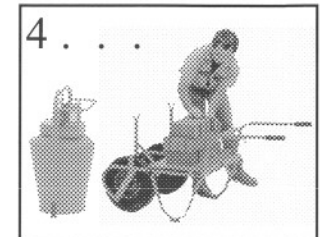
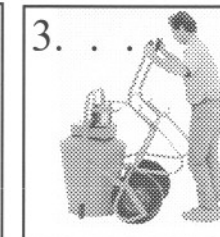

11250-100 = 7-14-04 = P-2

CANOGA® Equipment "Better Because We Build Them Better!"

CANOGA® Equipment Model 100

# IDENTIFYING PART NUMBERS

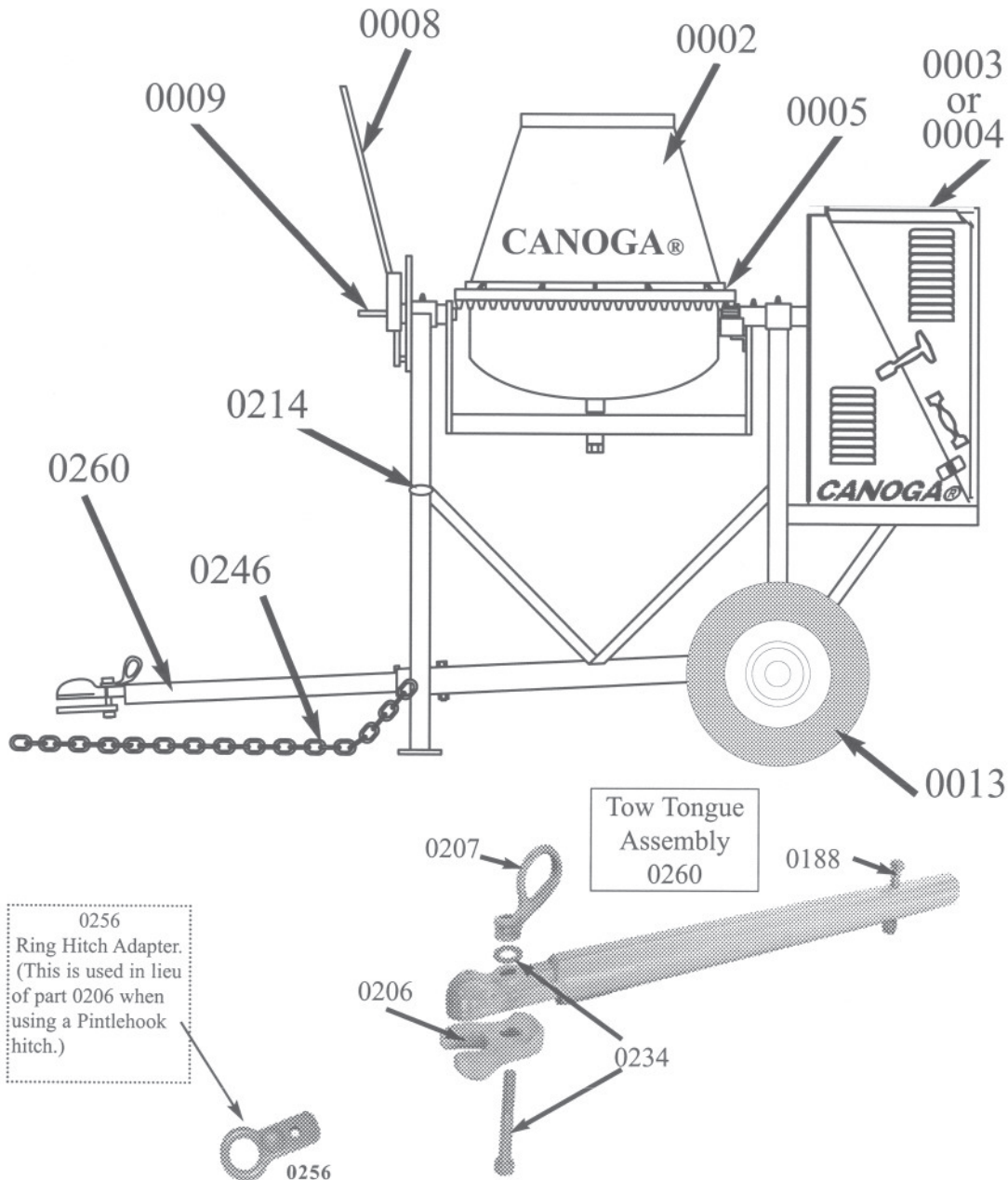

CANOGA® Equipment Model 100

# Safety & Electrical

**CAUTION!**

**ELECTRIC MOTOR MODEL**

**CAUTION!**

THE 100 SERIES CONCRETE MIXER HAS A STANDARD 1/2 H.P. 115/230 ELECTRIC MOTOR. IF IT IS WIRED FOR 115 VOLTS IT REQUIRES 8.4 AMPS. IF IT IS WIRED FOR 230 VOLTS IT REQUIRES 4.2 AMPS. **REMEMBER!** - WARRANTY IS VOID IF YOU DO NOT USE THE PROPER SIZE EXTENSION CORD.

The wire gauge selection will vary with the length of the extension cord from the power source and the amperage required by the motor:

| SIZE OF WIRE | 25 FT. LENGTH | 50 FT. LENGTH | 100 FT. LENGTH | 250 FT. LENGTH |
|--------------|---------------|---------------|----------------|----------------|
| 14-GAUGE     | 15 AMPS       | 15 AMPS       | 13 AMPS        | 7 AMPS         |
| 12-GAUGE     | 20 AMPS       | 20 AMPS       | 15 AMPS        | 11 AMPS        |
| 10-GAUGE     | 30 AMPS       | 30 AMPS       | 20 AMPS        | 18 AMPS        |

**• ATTENTION •**

**If automatic shut-down switch on motor activates, please note:**  
The motor has a manual reset thermal protector. If the motor overheats, the thermal protector will open the motor circuit and the motor will stop running. If this occurs, turn the switch to the motor off and after the motor cools sufficiently, push the reset button on the motor. Listen for a click of the reset button, which indicates that the motor has cooled sufficiently and the thermal protector has closed the motor circuit. The motor can then be restarted by turning on the switch to the motor.

**• WARNING •**

The Motor must be grounded in accordance with the national electrical code and local codes by trained personnel to prevent serious electrical shocks. To service the motor, disconnect the power source from motor and any accessory devices and allow motor to come to a complete stand still.

11250-100 = 7-14-04 = P-3

FOR ASSISTANCE CALL OUR SERVICE DEPARTMENT: 1-800-421-5830

# PERIODIC MAINTENANCE

## 1. MAINTENANCE PERFORMED EVERY DAY.

- A. Lubricate grease fittings as shown per diagram below.
- B. Clean mixer thoroughly after each use.
- C. Check engine oil level per instructions in engine owner's manual.
- D. Visually check all bolts, nuts, etc. for tightness and condition, and tighten with the proper tools.

## 2. MAINTENANCE PERFORMED EVERY 40 HOURS OF OPERATION.

- A. Check V-Belt tension and adjust as necessary.
- B. Check tire pressure. Inflate to pressure recommended on the side-wall of the tire.
- C. Check engine owner's manual for necessary periodic maintenance such as engine oil change, air filter cleaning etc.
- D. Check gear mesh & adjust/replace as necessary (see repair section III).

## 3. MAINTENANCE PERFORMED EACH YEAR.

A. Remove V-Belt(s). Remove bowl shaft cotter pin. Tighten bowl shaft nut until mixing bowl is hard to rotate by hand. If bowl shaft turns when you try to tighten the nut, you will need to tighten the setscrew located near the bowl shaft nut first. Loosen the bowl shaft nut until the mixing bowl rotates easily by hand and the cotter pin can be inserted in the bowl shaft. Install the cotter pin and V-Belts.

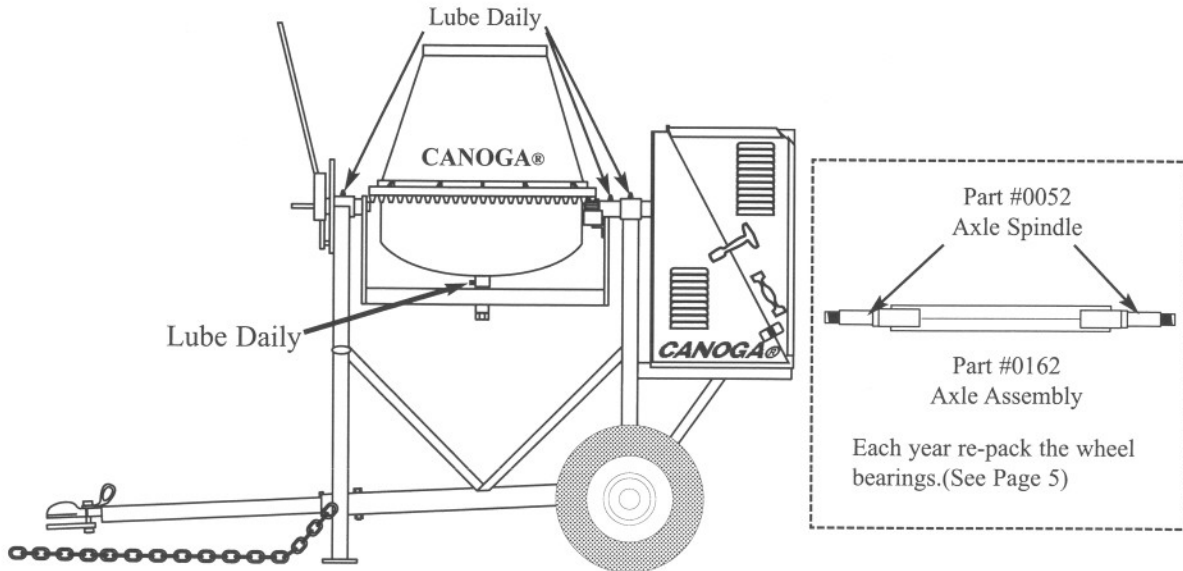

CANOGA® Equipment Model 100

# MODEL 100 PARTS LIST

| Part Number | Description   | Quantity required | Part Number | Description   | Quantity Required |
|-------------|---|-------------------|-------------|---|-------------------|
| 0001        | chassis for model #100B series electric                 | 1                 | 0045        | 1/2 h.p. electric motor                                     | 1                 |
| 0002        | mixing drum (includes paddles)                          | 1                 | 0047        | 4 h.p. Honda Engine   | 1                 |
| 0003        | engine enclosure (gasoline powered)                     | 1                 | 0048        | CANOGA name plate (Not For Sale)                            | 1                 |
| 0004        | engine enclosure (electric powered)                     | 1                 | 0049        | housing for bowl shaft and bearings                         | 1                 |
| 0005        | ring gear (includes fasteners)                          | 1                 | 0050        | yoke nipple   | 1                 |
| 0006        | chassis for model #100B series with gas engine          | 1                 | 0051        | housing for pinion shaft                                    | 1                 |
| 0007        | dump handle (assembly)                                  | 1                 | 0052        | axle spindle  | 2                 |
| 0008        | dump handle (only)                                      | 1                 | 0058        | mixing paddle   | 2                 |
| 0009        | return spring, bolt & nut assembly for dump handle      | 1                 | 0150        | owner's parts manual  | 1                 |
| 0010        | pivot bolt & "self locking" nut for the dump handle     | 1                 | 0151        | 1 gallon paint (CANOGA® orange)                             | 1                 |
| 0011        | wheel assembly  | 2                 | 0156        | 5/16" quick link  | 1                 |
| 0012        | wheel 1700-8 x 3.75 (includes races)                    | 2                 | 0158        | 1" spacing washer   | 1                 |
| 0013        | tire (only) 4.80 x 8"                                   | 2                 | 0159        | toggle switch for electric motor (replacement)              | 1                 |
| 0014        | wheel bearing   | 4                 | 0162        | axle assembly (rigid)                                       | 1                 |
| 0015        | wheel race  | 4                 | 0167        | valve stem  | 2                 |
| 0016        | wheel grease seal                                       | 2                 | 0168        | "U"-ground plug 15 amp.                                     | 1                 |
| 0017        | wheel dust cap  | 2                 | 0169        | "Twist Lock" plug 20 amp.                                   | 1                 |
| 0018        | axle nut  | 2                 | 0170        | cable connector (small)                                     | 1                 |
| 0019        | 1/8" x 2" cotter pin                                    | 3                 | 0172        | power cord-3 wire, 14 gauge, 15 inches long                 | 1                 |
| 0020        | bowl shaft assembly                                     | 1                 | 0173        | ring connector  | 1                 |
| 0021        | bowl shaft  | 1                 | 0174        | spade connector-small                                       | 1                 |
| 0022        | 2-1/2" expansion plug for the inside of the mixing bowl | 1                 | 0175        | spade connector-large                                       | 3                 |
| 0023        | bowl shaft bearings                                     | 2                 | 0176        | "U" drive screw ( to attach CANOGA® serial # tag)           | 2                 |
| 0024        | bowl shaft race   | 2                 | 0177        | serial tag (not for sale)                                   | 1                 |
| 0025        | grease seal for bowl shaft                              | 1                 | 0178        | tank head(26" diameter - 3/16" thick) bottom of mixing drum | 1                 |
| 0026        | 1/8" N.P.T, straight grease fitting                     | 4                 | 0181        | slam door latch   | 1                 |
| 0027        | bowl shaft castle nut                                   | 1                 | 0184        | door hinge (bent) 28" long for gas engine enclosures        | 1                 |
| 0028        | bowl shaft set screw & lock nut                         | 1                 | 0188        | bolt & lock nut to attach tow tongue to chassis             | 1                 |
| 0029        | pinion gear guard                                       | 1                 | 0206        | hitch fork (forged)   | 1                 |
| 0030        | pinion shaft assembly                                   | 1                 | 0207        | hitch wing nut (cast iron)                                  | 1                 |
| 0031        | pinion gear   | 1                 | 0211        | 2" ball hitch body to fit 2" pipe for tow tongue            | 1                 |
| 0032        | pinion shaft  | 1                 | 0213        | rubber latch clamp (door) for gas engine enclosure          | 1                 |
| 0033        | pinion shaft bearing                                    | 2                 | 0214        | 3/8" x 2" hose nozzle ring                                  | 2                 |
| 0034        | pinion shaft race                                       | 2                 | 0216        | tow tongue with "drop pin hitch plate"                      | 1                 |
| 0035        | special 3/4" spacing washer                             | 1                 | 0220        | door pull handle (metal) for gas engine enclosure           | 1                 |
| 0036        | special 1" spacing washer                               | 1                 | 0234        | bolt & washer assembly for hitch fork on tow tongue         | 1                 |
| 0037        | 15" single groove driven pulley for electric motor      | 1                 | 0235        | metal pocket for "Owners Manual"                            | 1                 |
| 0038        | 18" single groove driven pulley for gas engine          | 1                 | 0244        | 5/16" lap link (to attach safety chain to chassis)          | 1                 |
| 0039        | pulley hub H-1  | 1                 | 0246        | safety chain (1/4"x72" long)                                | 1                 |
| 0040        | square drive key 1/4"                                   | 1                 | 0250        | door hinge unbent 28" long for electric motor enclosure     | 1                 |
| 0041        | 2" drive pulley for electric motor                      | 1                 | 0252        | yoke assembly   | 1                 |
| 0042        | 2" drive pulley for gas engines                         | 1                 | 0256        | ring hitch adapter for "Pintle Hook Hitch"                  | 1                 |
| 0043        | V-belt for electric motor                               | 1                 | 0260        | towing tongue for 2" ball hitch (complete)                  | 1                 |
| 0044        | V-belt for gas engine                                   | 1                 |             |   |                   |

11250-100 = 7-14-04 = P-4

CANOGA® Equipment Model 100

## WHEEL-TIRE-AXLE PARTS



0012 Wheel (ONLY)  
with races 0015



4.00 x 8"  
Tire For Model 100  
0013 Tire (ONLY)

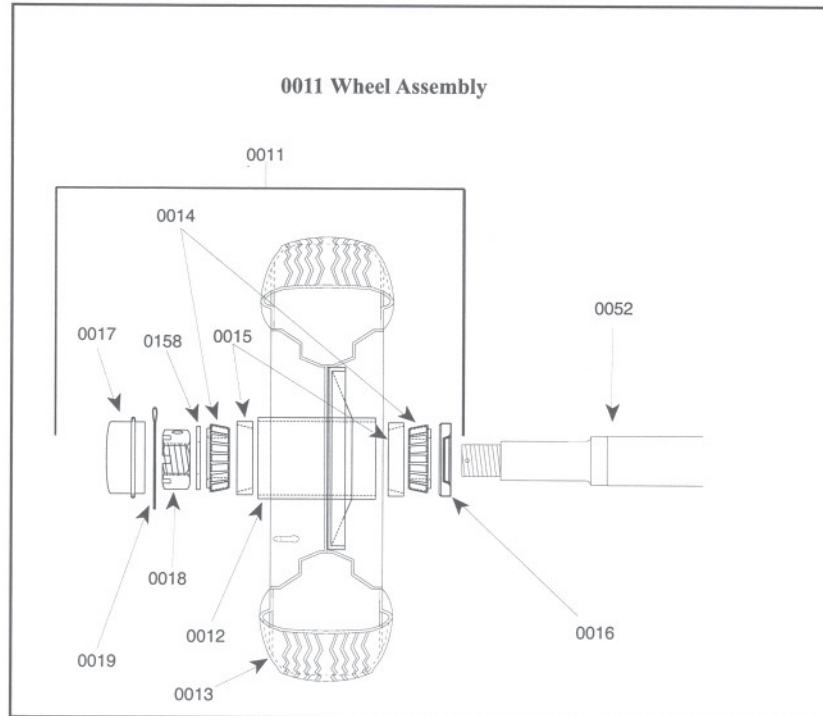

This complete wheel assembly is for Model #100. Part 0052 is not a part of this assembly. (See page 4 "Axle Assembly")

For assistance call our service department. 1-800-421-5830

CANOGA® Equipment Model 100

## MAINTENANCE SECTION (Continued)

• **WHEEL MAINTENANCE PERFORMED EACH YEAR** •  
Grease wheel bearings. Jack up the mixer and remove the dust cap, cotter pin and nut on each wheel. Pull the wheel off the spindle carefully. Avoid letting the outside bearing fall to the ground while removing the wheel. Remove the wheel grease seals. Inspect all bearings and races for wear and replace as necessary. Pack all bearings with automotive wheel bearing grease, Reassemble the wheels, being careful not to let the bearings become contaminated with dirt or other foreign matter. Tighten the spindle nut until the wheel stops rotating freely. Then loosen the nut until the wheel turns freely again and the nut is aligned to the hole in the spindle so that the cotter pin can be installed (usually 1/8 to 1/4 of a turn). Install the dust caps. Check the tire pressure. (Inflate them to the pressure recommended on the side-wall of the tire.)

## HELPFUL HINTS AND INFORMATION

• **HONDA GASOLINE POWERED MIXERS** •  
**SHUT OFF FUEL VALVE ON CARBURETOR**  
**WHEN TOWING MIXER!**  
**IF YOU FAIL TO DO THIS.....**

THE ENGINE CYLINDER MAY FILL WITH GASOLINE MAKING THE ENGINE UNABLE TO START. TO CLEAR THIS, IT MAY BE NECESSARY TO REMOVE THE SPARK PLUG FROM THE ENGINE. PULL THE STARTER CORD SEVERAL TIMES TO FORCE THE RAW FUEL FROM THE PISTON CHAMBER THROUGH THE SPARK PLUG HOLE. REPLACE THE SPARK PLUG AND THE SPARK PLUG WIRE. IN ADDITION, CHECK THE OIL TO MAKE SURE THE FUEL HASN'T SPILLED INTO THE BLOCK, THUS CONTAMINATING THE OIL AND RAISING THE OIL LEVEL. THIS WOULD CAUSE THE ENGINE TO RUN POORLY OR STOP RUNNING. IF THIS HAPPENS, CHANGE THE OIL AND START THE ENGINE BY USING THE USUAL PROCEDURE.

(REFER TO THE ENGINE MANUAL.)

## DEPARTMENT OF MOTOR VEHICLE REGISTRATION?

Check with the Department of Motor Vehicles in your state.

In California, all towable equipment are required to have "Special Equipment" license plates issued by the Department of Motor Vehicles. At present there is a one time fee for the life of the equipment. Applications can be picked up at the DMV office. Also check with the DMV if lights or fenders are required for towing. The *Owner/Operator* of a mixer should contact the Highway Patrol and/or the DMV from time to time to keep current with the codes.

11250-100 = 7-14-04 = P-5

CANOGA® Equipment Model 100

## Repair Section

**CAUTION!** Disconnect the electrical cord on electric mixers or the spark plug on gasoline powered mixers before attempting any maintenance.

### I. BOWL BEARING/SHAFT REPLACEMENT

Remove the V-Belt(s). Tilt the mixing drum so that the mouth of the drum is pointing down. Remove the cotter pin on the mixing drum shaft nut. Loosen the set screw next to the mixing drum shaft nut. Loosen the drum shaft nut two or three turns. Place a wood block or some other object over the nut to protect it from damage. Strike the wood block with a large hammer until the mixing drum shaft breaks free. Loosen the nut further and continue to strike the wood block further and continue striking it until the mixing drum falls free from the yoke. Be sure to have a double saw horse type of platform for the mixing drum to land on safely! **Caution:** It is recommended that another person steady the mixing drum when it falls; otherwise it could fall over on its side and break the ring gear. Place the mixing drum vertically on the ground with the drum opening resting on the ground. Drive the mixing drum shaft through the mixing drum using a bar of steel or a large drift punch. As you drive out the mixing drum shaft, the end will knock out the expansion plug which seals the inside end of the bearing housing. Remove the outside grease seal by prying it out with a large screwdriver. Clean and inspect the bearings and their races: replace as necessary. To remove the bearing races from the bearing housing use a long steel bar and a large hammer. Place the steel bar through the housing from the opposite end of which the race is to be removed. Place the steel bar against the edge of the race and strike the steel bar with a hammer. Repeat the procedure on the opposite side of the race 180° from the initial strike. Alternate from side to side until the race is pounded out. Install the new races making sure the larger opening of the race faces outward. Pack the bearing with wheel bearing grease. Install one bearing in the race on the outside bottom of the mixing drum. Install a grease seal over the bearing. Take the mixing drum shaft and lightly center-punch it 1/2" below the collar that is welded to the end of the drum shaft. This helps to ensure that the bearing will not turn on the shaft. Install the other greased bearing on the shaft and press on the bearing until it bottoms against the welded collar. If you are installing a new shaft, measure where the bottom bearing was located on the old shaft. Lightly center-punch the mixing drum shaft in this area or re-center-punch the shaft if you are using the old shaft. Tilt the yoke so that if the mixing drum were on it, the mouth of the mixing drum would be pointing straight up. Position the mixing drum on the yoke and align the hole for the mixing drum shaft in the mixing drum and the yoke. Insert the mixing drum shaft from the inside. It is recommended that someone steady the mixing drum while the mixing drum shaft is inserted. The shaft can be inserted by hand until the area that is center-punched reaches the bottom bearing. It will now be necessary to drive the shaft the rest of the way with a long steel bar and a hammer. Install the mixing drum shaft nut and lightly tighten the setscrew next to the nut. Tighten the mixing drum shaft nut until the drum becomes hard to turn by hand. **Caution: When turning the mixing drum,** be careful to avoid catching your fingers between the ring gear and the pinion gear! If the drum shaft turns with the nut, tighten the setscrew more. Loosen the mixing drum shaft nut until the mixing drum turns freely and the cotter pin can be inserted into the shaft. Tighten the set screw. Install a new expansion plug inside the mixing drum with the convex side facing out. Expansion plugs cannot be reused. You must use a new one. Using a long steel bar and a hammer, pound on the center area of the expansion plug until it is relatively flat. This will expand the outside diameter of the plug so that it will seal. If you pound on the plug too much and make it concave instead of flat, you will have to install a new plug and try again.

## MODEL 100 PARTS

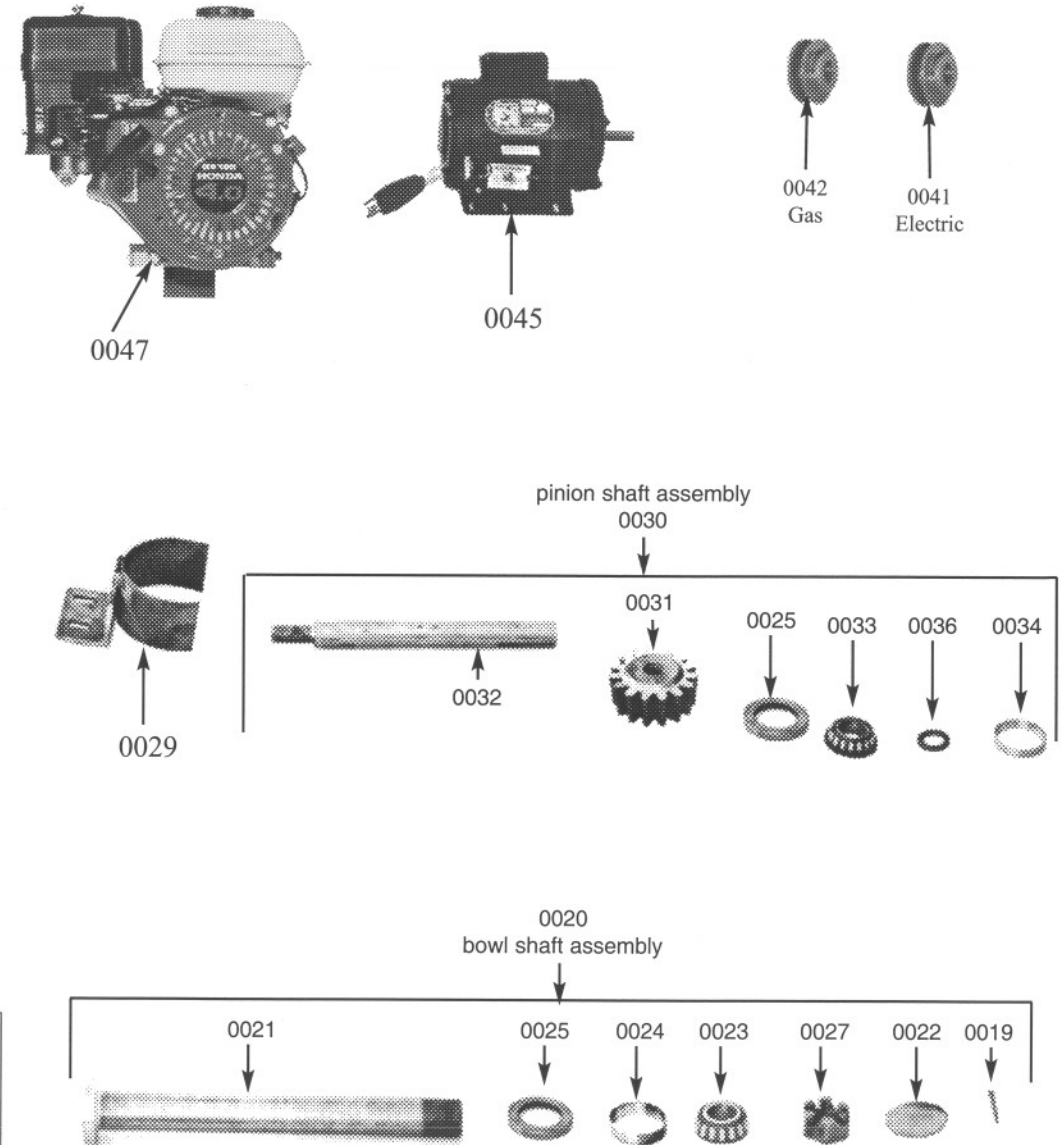

# MODEL 100 PARTS

CANOGA® Equipment

**“Better Because We Build Them Better!”**

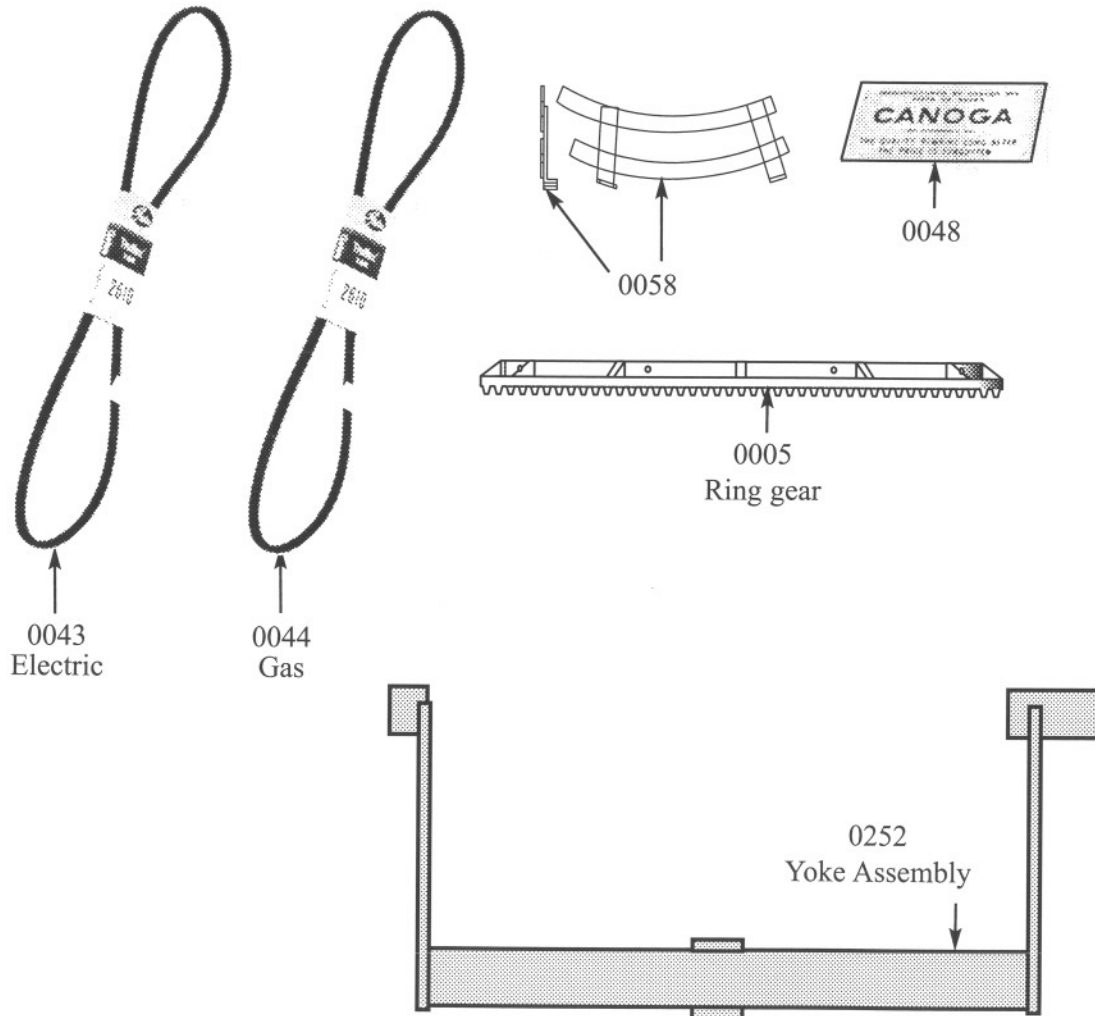

# REPAIR SECTION

## II. PINION GEAR, PINION SHAFT/BEARING REPLACEMENT

Remove the mixing drum as described in paragraph I on the previous page. While someone holds the drive pulley, remove the pinion gear jam nut. The use of an impact wrench might be necessary to loosen the nut. Note: Some model mixers have right-hand threads while others have left-hand threads on the pinion gear/shaft/nut. Determine proper direction before attempting to loosen the pinion gear or nut. While someone holds the pulley, place a pipe wrench on the pinion gear and remove the gear. Remove the screws located on the drive pulley hub. Insert the screws in the threaded holes in the pulley hub flange. Tighten the screws evenly until the pulley becomes loose on the hub. Use a gear puller and remove the pulley/hub assembly. Remove the washers behind the pulley. Drive the pinion shaft out of its bearing housing using a long metal bar or a drift punch. Remove the bearing and seals. Clean all parts and inspect for wear or damage. If removal of the bearing races from the pinion shaft housing is necessary, use a long steel bar and a large hammer. Place the steel bar through the housing from the opposite end from which the race is to be removed. Place the steel bar against the edge of the race and strike the bar with the hammer. Repeat the procedure on the opposite side of the race 180° from the initial strike. Alternate from side to side until the race is pounded out. If you are installing a new pinion shaft, observe the old shaft where it has been center-punched and lightly center-punch the new shaft in the same locations. This will ensure that the bearings will not rotate on the pinion shaft. If you are using the old pinion shaft, re-center-punch the shaft where it was punched previously. Place the pinion shaft in a vice with the threaded end up, leaving approximately 4" above the vice. Pack both bearings with wheel bearing grease. Place the greased bearing on the shaft with the seal up. Place a washer (if there was a washer between the bearing and the pinion gear originally. Some machines do not have a washer.) on top of the bearing. Screw the pinion gear onto the pinion shaft. Use a pipe wrench and tighten the pinion gear onto the pinion shaft. As the pinion gear is screwed on the shaft, it should push the bearing further onto the shaft to its proper location. Install a jam nut and tighten. Remove the pinion shaft assembly from vise. Install the pinion shaft assembly into shaft housing. Install the washers that were in between the pulley and rear bearing on the pinion shaft. Remove and reinstall, in their original holes, the screws that hold the pulley to the hub. Do not tighten these screws at this time. Two or three turns of each screw is sufficient. Place the pulley on the pinion shaft making sure the key-way slots are aligned. Drive the pulley onto the shaft by lightly tapping the pulley hub (not the pulley) with a plastic mallet. Insert the square drive key between the pulley hub and the shaft. Make sure that the pulley is as far onto the shaft as it will go, paying particular attention that there isn't any space between the pulley hub and washers or the washer and the rear bearing. Tighten the screws in the pulley hub evenly. Reinstall the mixing drum as described in paragraph I. Check the ring gear/pinion gear mesh. If it is not satisfactory, read paragraph III and correct as necessary. Reinstall the V-belts.

## REPAIR SECTION

### III. RING GEAR REPLACEMENT/ADJUSTMENT

Remove V-belt(s) from the machine. Remove the old ring gear including the bolts from the mixing drum. On older machines, it is usually easier to torch off the bolts than to try to use wrenches. At the factory, we individually fit each gear to its machine to obtain the best fit possible. Because of this, it is unlikely that the holes in your new gear will match the holes in the mixing drum. Weld up the holes in the mixing drum and grind flush the welds on the outside of the mixing drum. With your new gear you will find a package containing all the necessary mounting, plus four 3/8" bolts. Thread the four 3/8" bolts into your four tapped holes in your new gear a couple of turns.

**CAUTION!** The ring gear is made of cast semi-steel. If you drop, hit or tighten the bolts to hard, you may break the gear. Tip the mixing drum until it is horizontal. Slid the gear onto the drum until it is in the approximate location desired. Make sure that the holes in the gear are *not* located over the previous welded-up holes. Tighten the four 3/8" bolts both evenly and lightly until the same amount of gap between the gear and mixing drum exists all around the mixing drum. The four 3/8" bolts are now used as setscrews to hold the gear in position while holes are drilled in the side of the mixing drum. Tilt the drum until the mouth is pointing straight up. Tap the gear gently near the four 3/8" bolts with a hammer until the gear meshes properly. Proper mesh is obtained by tapping the gear down evenly until the gear starts to bind, then up slightly until it is easy to turn the mixing drum by hand. Select a hole in the gear that *does not* have a 3/8" bolt in it. Using the hole in the gear as a guide, drill a hole in the side of the drum with a drill the same size as the bolts used with your gear to mount it. Flat washer(s) should now be placed between the gear and the drum. If the gap between the gear and the drum is not filled with washers (none to four as required), when you tighten the mounting bolts you will crack the flange of the ring gear. Use a drift punch to align the hole in the drum, that you just drilled, with the hole(s) in the washer(s). Place a bolt from the inside through the hole and install a lock washer and a nut on the outside. Tighten the nut and check the gear mesh. If the gear mesh is incorrect, loosen the nut and tap the gear up or down as necessary, then retighten the nut. Repeat the above nut installing sequence at each hole that *does not* have a 3/8" bolt in it. If you are satisfied that the gear is meshing correctly all of the way around, remove one of the 3/8" bolts and install the correct mounting bolts as described above. Continue to remove one 3/8" bolt at a time and install the mounting bolts as described above. When you are finished, check the entire gear for proper mesh and adjust as necessary. Reinstall V-belts.

*For assistance call our service department. 1-800-421-5830*

## MODEL 100 PARTS

