

A | B | C | D | E | F | G | H | I | J

REVISIONS				
ZONE	REV	DESCRIPTION	DATE	APPROVED
-	-	INITIAL RELEASE - ECO 1073	08/11/04	AJG

NOTES:

1. REMOVE (3) .187 DISCONNECTS FROM WIRE LEADS.
2. ATTACH (1) NEW MALE .250 DISCONNECT (154538) TO BLACK WIRE.
3. ATTACH (2) NEW FEMALE .250 DISCONNECTS (154539) TO YELLOW AND BROWN WIRES.
4. CONNECT NEW MOTOR LEADS TO HARNESS PER DRAWING.

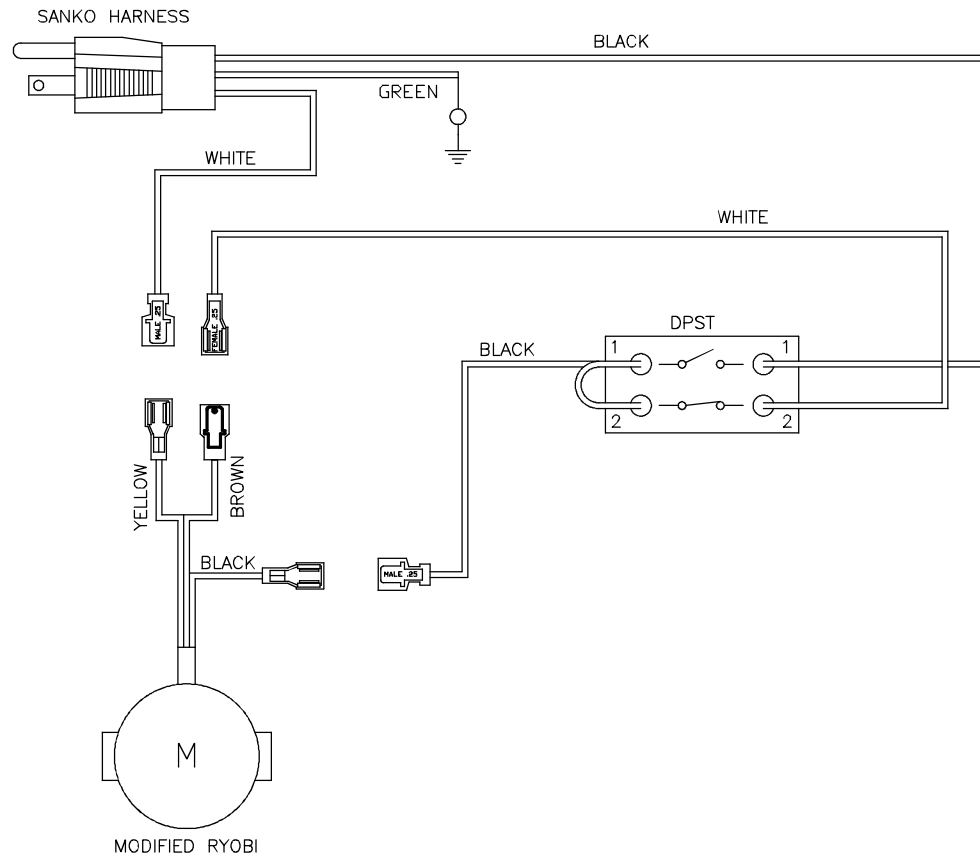
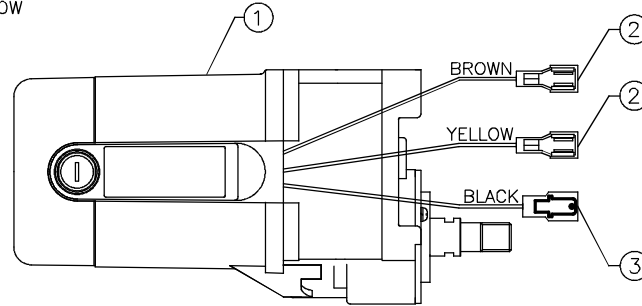

1	154538	TERMINAL, .250 MALE	FULLY INSULATED	3
2	154539	TERMINAL, .250 FEMALE	FULLY INSULATED	2
1	157801-R	MOTOR, RYOBI 15A/120V	NONE	1

QTY. REQ.	PART OR IDENTIFYING NO.	MATERIAL/SPECIFICATION	FINISH	ITEM NO.
PARTS LIST				
TOLERANCES UNLESS OTHERWISE SPECIFIED		DATE	MK DIAMOND PRODUCTS INC. 1315 STORM PARKWAY TORRANCE, CA. 90501	
DIMENSIONS ARE IN INCHES		DRAWN AJG 08/11/04		
<ul style="list-style-type: none"> • WHOLE NO. AND FRACTIONS = ±1/32 • .X = ±.03 • .XX = ±.010 • .XXX = ±.005 • ANGLES = ±1/2° • DRILL = • PUNCH = 		CHECK SMH 08/13/04		
		DESIGN AJG 08/11/04		
		APPROV	MOTOR, SANKO REPLACEMENT INSTRUCTION SHEET	
		NEXT ASSY.		
DO NOT SCALE DRAWING		APPLICATION	SCALE: NONE	REV. -

MK MK DIAMOND PRODUCTS INC.
1315 STORM PARKWAY
TORRANCE, CA. 90501

MOTOR, SANKO REPLACEMENT INSTRUCTION SHEET

SIZE C	PART NO. 157801-IS	REV. -
SCALE: NONE		SHEET: 1 OF 1