



MK-101 w/JCS Stand

**TILE SAW
OWNER'S MANUAL &
OPERATING INSTRUCTIONS**



CAUTION:
Read all safety and
operating instructions
before using this
equipment

Enter the Serial Number of your new saw in the space below. The Serial Number is located on the left side of the blade guard.

SERIAL NUMBER:

NOTE:

For your (1) one year warranty to be effective, complete the warranty card (including the Serial Number and mail it in as soon as possible.

EXPLODED VIEW AND PARTS LIST

EXPLODED VIEW:

See Page 42 for
Sub-Assemblies F-J

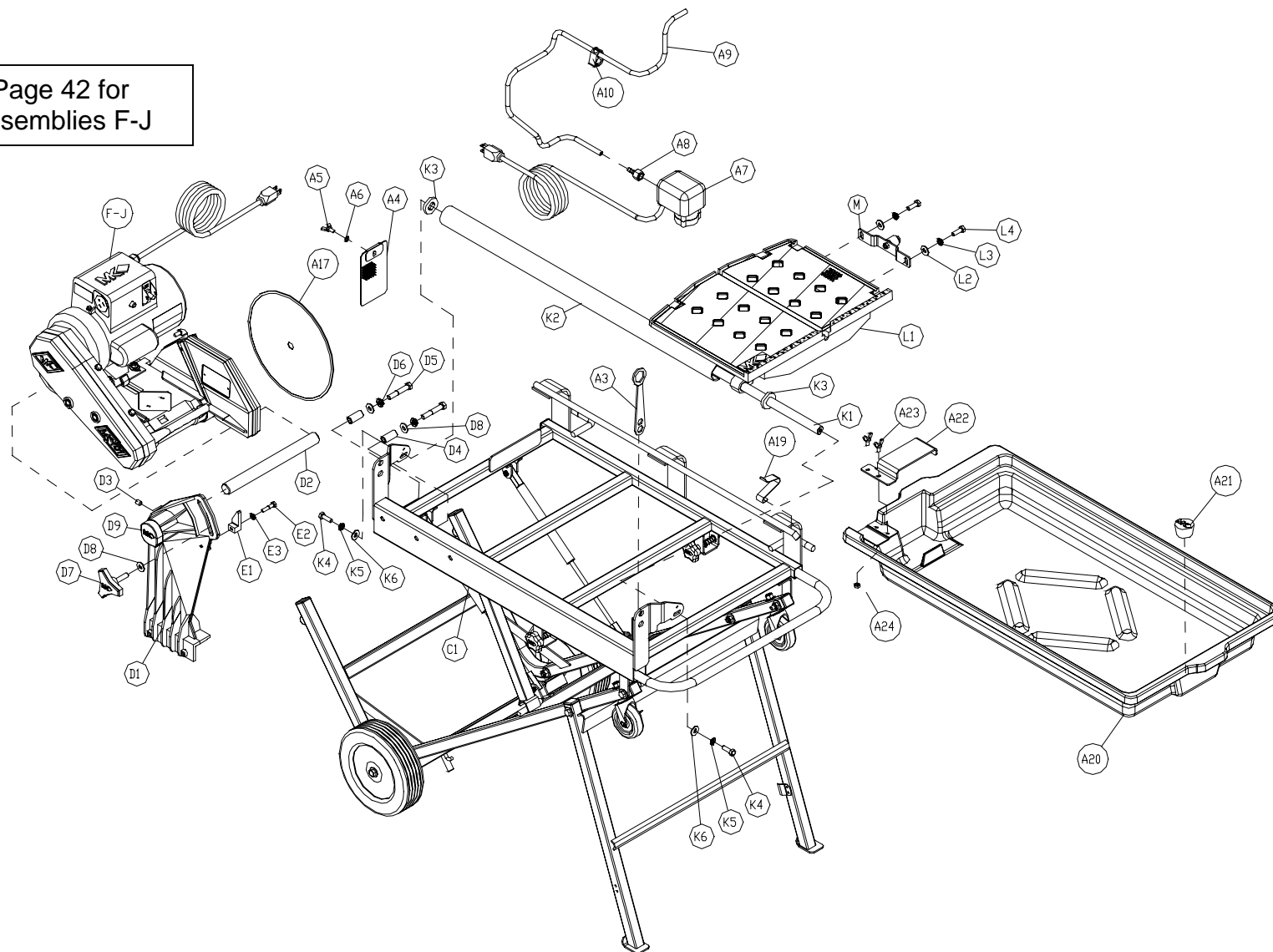

EXPLODED VIEW AND PARTS LIST

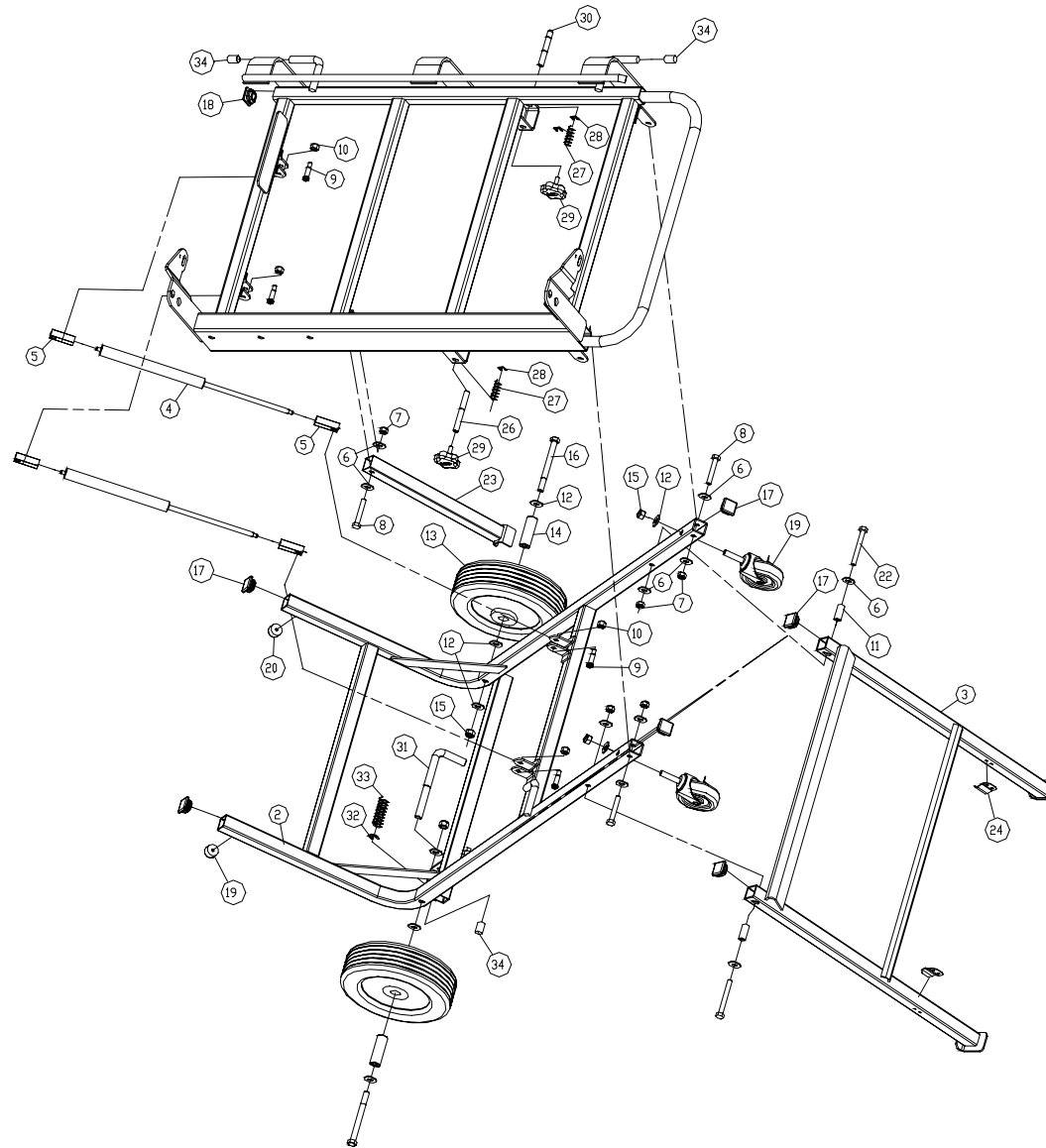

EXPLODED VIEW AND PARTS LIST

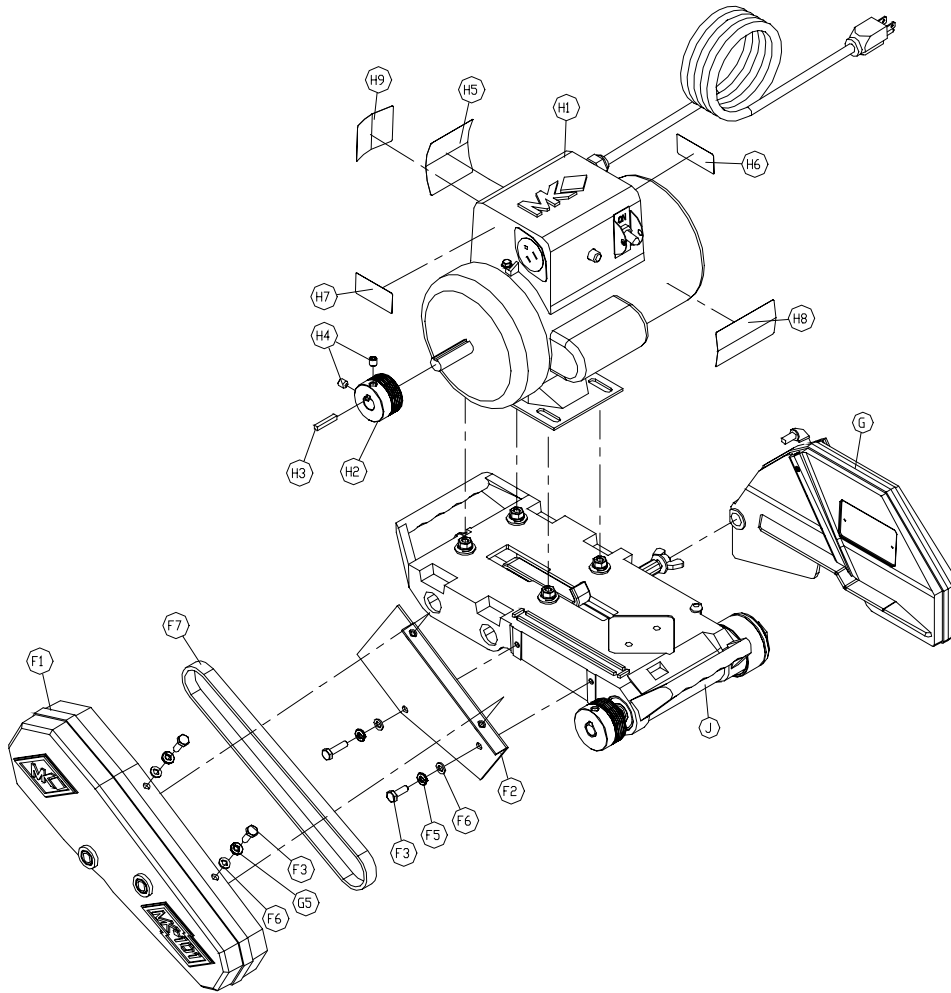

Sub-Assemblies "F" and "G"

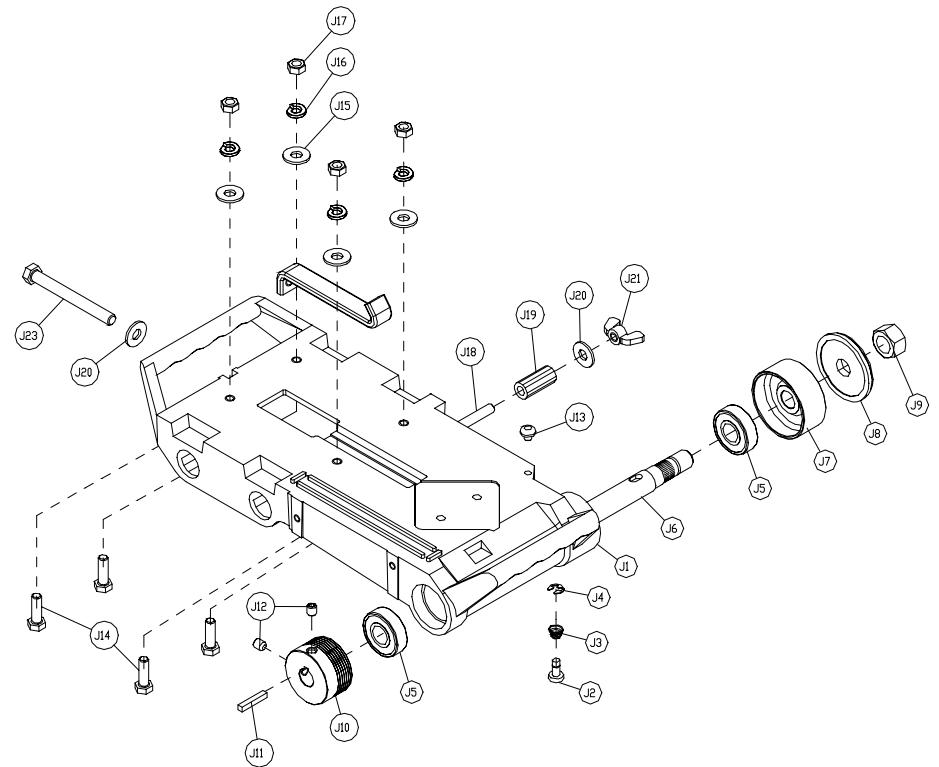

Sub-Assembly "J"

EXPLODED VIEW AND PARTS LIST

PARTS LIST:

Item	Description	Qty	Part #	*Rev
A	Accessories	-	-	-
A1	Carton, Accessory Pack, 10	1	153366	*
A2	Foam, Accessory Pack Carton	1	154022	*
A3	Wrench, 15/16 Closed End	1	134684	*
A4	Guard, Splash	1	160310	*
A5	Wingscrew, 1/4-20 X 1/2	1	151888	
A6	Washer, 1/4 SAE Flat	1	151915	
A7	Pump, Water, G-150A	1	151271	*
A8	Fitting, Plastic, 1/4 FNPT X 1/4 BARB	1	128397	
A9	Hose, Vinyl, 1/4 ID	6'	132951	
A10	Clamp, Flow, 1/4-1/2	1	154394	
A11	Rip Guide, Large Die Cast	1	159751	*
A12	Miter, Large Bullnose	1	153201	*
A13	Owner's Manual, MK-101 Portable Tile Saw	1	162059	*
A14	Card, MK Warranty Registration	1	155037	*
A15	Label, Do Not Return	1	157063	*
A16	Sell Sheet, Tile Accessory	1	156915	*
A17	Blade, MK-100, 10 X 060 X 5/8	1	154380	*
A18	Tag, Serial Number, Blank	1	157500	*
A19	Clip, Table Lock, 30 deg	1	160331-1	*
A20	Pan, Plastic, 101	1	150634	*
A21	Plug, Rubber Drain	1	153439	*
A22	Clamp, Holding , Pump	1	162054	*
A23	Screw, Wing, 1/4-20 x 1/2	2	151888	*
A24	Nut, Hex, 1/4-20	2	151893	*
A25	Sheet, Set Up Instructions (Not shown in Exploded View)	1	162082	
C	Frames	-	-	-
C1	Assembly, Portable Stand	1	160705	*
D	Posts	-	-	-
D1	Post, DC, 101, MK Red	1	158438	*
D2	Shaft, 10.63" Pivot, 101	1	153254	*
D3	Screw, 3/8-16 X 1/2 Socket Head Set	1	153710	*
D4	Spacer, 5/8X.385X1.4	2	160654	*
D5	Screw, 3/8-16 X 2 1/2 Hex Head Cap	2	156030	*
D6	Washer, 3/8 Split Lock	2	150925	*
D7	Knob, 3/8-16 X 1.5 MK Adjustment	1	156770-02	*
D8	Washer, 3/8 SAE Flat	3	150923	*
D9	Plastic Post Cover	1	160157	
E	Stop, Cutting Head			
	Kit, Stop 10" Cutting Head	1	157728-MK	
E1	Stop, 10" Cutting Head	1	157728	*
E2	Screw, 1/4-20 X 1 1/4 Hex Head Cap	1	157145	*
E3	Washer, 1/4 Split Lock	1	152591	*
E4	Sheet, Cutting Head Stop Instruction	1	157728-IS	*
F	Belt Guards	-	-	-
F1	Belt Guard, MK-101	1	158319-01	*
F2	Bracket, Inner Belt Guard, 100/101	1	158611	*
F3	Screw, 1/4-20 x 3/4 Hex Head Cap	3	152370	*
F4	Screw, 1/4-20 x 1 Hex Head Cap	1	152676	*
F5	Washer, 1/4 Split Lock	4	152591	*

EXPLODED VIEW AND PARTS LIST

F6	Washer, 1/4 SAE Flat	4	151915	*
F7	Belt, 260J6 Micro-V	1	158194	*
G	Assembly, Blade Guard	1	152582	
G1	Blade Guard, 101/115	1	153659	*
G2	Tube, Water	2	155389	*
G3	Screw, 5/16-18 X 1/2 Socket Head Set	3	152607	*
G4	Elbow, 1/8 MNPT X 1/4 BARB 90° Brass	1	154652	*
H	Motors	-	-	-
H1	Motor, 1-1/2HP\120V\60Hz	1	160127	*
H2	Pulley, 6J17 X 5/8 Bore	1	158214	*
H3	Key, 3/16 x 3/16 x 1-1/8 Square	1	150344	*
H4	Screw, 5/16-18 X 3/8 Socket Head Set, Cup Point	2	157083	*
H5	Label, Warning most motor..., 2 3/4 X 2 7/16	1	155672	*
H6	Label, Caution, GFCI, 1 X 2 1/8	1	155678	*
H7	Label, Caution, 5 Amp Max., 1 X 2-1/8	1	154822	*
H8	Label, Warning, Read Owner's Manual, 1-3/4 X 3-3/8	1	155806	*
H9	Label, MK Service Info., 2 1/8 X 1-13/16	1	155038	*
J	Assembly, Cutting Head	1	158191	-
J1	Cutting Head, DC, 100/101, MK Red	1	158224	*
J2	Pin, Blade Shaft Lock	1	158200	*
J3	Spring, Blade Guard Lock	1	158201	*
J4	E-Ring, 1/4 Retaining	1	158202	*
J5	Bearing, 17mm X 40mm X 12mm Ball (6203-2NSE)	2	137711	*
J6	Shaft, Blade 100/101	1	158222	*
J7	Flange, 2-3/8 Inner	1	137737	*
J8	Flange, 2-3/8 Outer	1	135830	*
J9	Nut, 5/8-18 Hex	1	135848	*
J10	Pulley, 6J19 X 5/8 Bore	1	158199	*
J11	Key, 3/16 x 3/16 x 1 1/8 Square	1	150344	*
J12	Screw, 5/16-18 X 3/8 Socket Head Set, Cup Point	2	157083	*
J13	Bumper, 1/2 Dia Rubber	1	152674	*
J14	Screw, 5/16-18 X 1 Hex Head Cap	4	151743	*
J15	Washer, 5/16 SAE Flat	4	151754	*
J16	Washer, 5/16 Split Lock	4	151747	*
J17	Nut, 5/16-18 Hex	4	101196	*
J18	Screw, 5/16-18 x 2 1/2 Hex Head Cap, Full Thread	1	151748	*
J19	Pivot, Blade Guard	1	153208	*
J20	Washer, 3/8 SAE Flat	2	150923	*
J21	Wingnut, 5/16-18 Nylock	1	151746	*
J22	Strap, Motor Adjustment	1	152673	*
J23	Screw, 3/8-16 X 3 1/2 Hex Head Full Thread	1	153147	*
K	Guide Bars	-	-	-
K1	Bar, 3/4 X 32 Guide, 101	1	134759	*
K2	Cover, Guide Bar, 120° X 35"	1	158403	*
K3	Spacer, Guide Bar Cover, 101	2	152393	*
K4	Screw, 5/16-18 X 1 Hex Head Cap	2	151743	*
K5	Washer, 5/16 Split Lock	2	151747	*
K6	Washer, 5/16 SAE Flat	2	151754	*
L	Tables	-	-	-
L1	Table, 100/101	1	157660	*
L2	Washer, 5/16 SAE Flat	2	151754	*

EXPLODED VIEW AND PARTS LIST

L3	Washer, 5/16 Split Lock	2	151747	*
L4	Screw, 5/16-18 X 1 Hex Head Cap	2	151743	*
M	Assembly, Roller Wheel	1	151756	-0-
M1	Bracket, Roller Wheel	1	154021	*
M2	Wheel, Roller	1	151799	*
M3	Screw, 1/4-20 X 1 1/2 Hex Head Cap	1	151914	*
M4	Washer, 1/4 SAE Flat	1	151915	*
M5	Nut, 1/4-20 Hex	1	151893	*

PARTS LIST FOR JCS STAND (SHOWN IN PAGE 41):

Item	Description	Qty	MK p/n
-	Assembly, Portable Stand, MK100/101/770EXP	1	160705
1	Weldment, Integrated Frame	1	160690
2	Weldment, Rear Support	1	160693
3	Weldment, Front Support	1	160700
4	Spring, Gas, 600N	2	160696
5	Fitting, End, Gas Spring	4	160695
6	Washer, 5/16 SAE	10	151754
7	Nut, Hex, Nylok, 5/16-18	5	158289
8	Screw, Hex, 5/16-18x2	3	155494
9	Screw, Shoulder, 5/16x3/4	4	160726
10	Nut, Hex, Nylok, 1/4-20	4	159857
11	Spacer, 1/2x5/16x1-1/8	2	160732
12	Washer, 3/8 SAE	8	150923
13	Wheel, 8x2-1/4	2	155986
14	Spacer, 3/4x3/8x2-1/4	2	160728
15	Nut, Hex, Nylok, 3/8-16	4	152505
16	Screw, Hex Hd, 3/8-16x4	2	153531
17	Plug, Plastic, 1 SQ., 10-14 Ga	6	160727-2
18	Plug, Plastic, 1 SQ., 14-20 Ga	1	160727-1
19	Caster, Swivel, 3" w/ 3/8-16 Stem	2	160735
20	Bumper, Rubber	2	159855
21	Rivet, Dome Style, 3/16 Dia x.251-.375 Grip	2	160729-3
22	Screw, Hex Hd, 5/16-18x2-3/4	2	152520
23	Weldment, Vertical Support	1	160934
24	Plate, Spring	1	160694
25	Rivet, Dome Style, 5/32 Dia x.063-.125 Grip	4	161226-1
26	Pin, Locking	1	160936
27	Spring, 1/2x.04x1.75	1	160697
28	Ring, Retaining, 3/8x.035	1	161171
29	Knob, Plastic	1	159428-1
30	Pin, Frame Locking	1	162055
31	Pin, Wheel Locking	1	162051
32	Ring, Retaining, 1/2x.042	1	162053
33	Spring, .600x.045x2.25	1	162052
34	Cap, Vinyl, 1/2-9/16x3/4	3	162057