

MK-100 TILE SAW OWNER'S MANUAL PARTS LIST & OPERATING INSTRUCTIONS

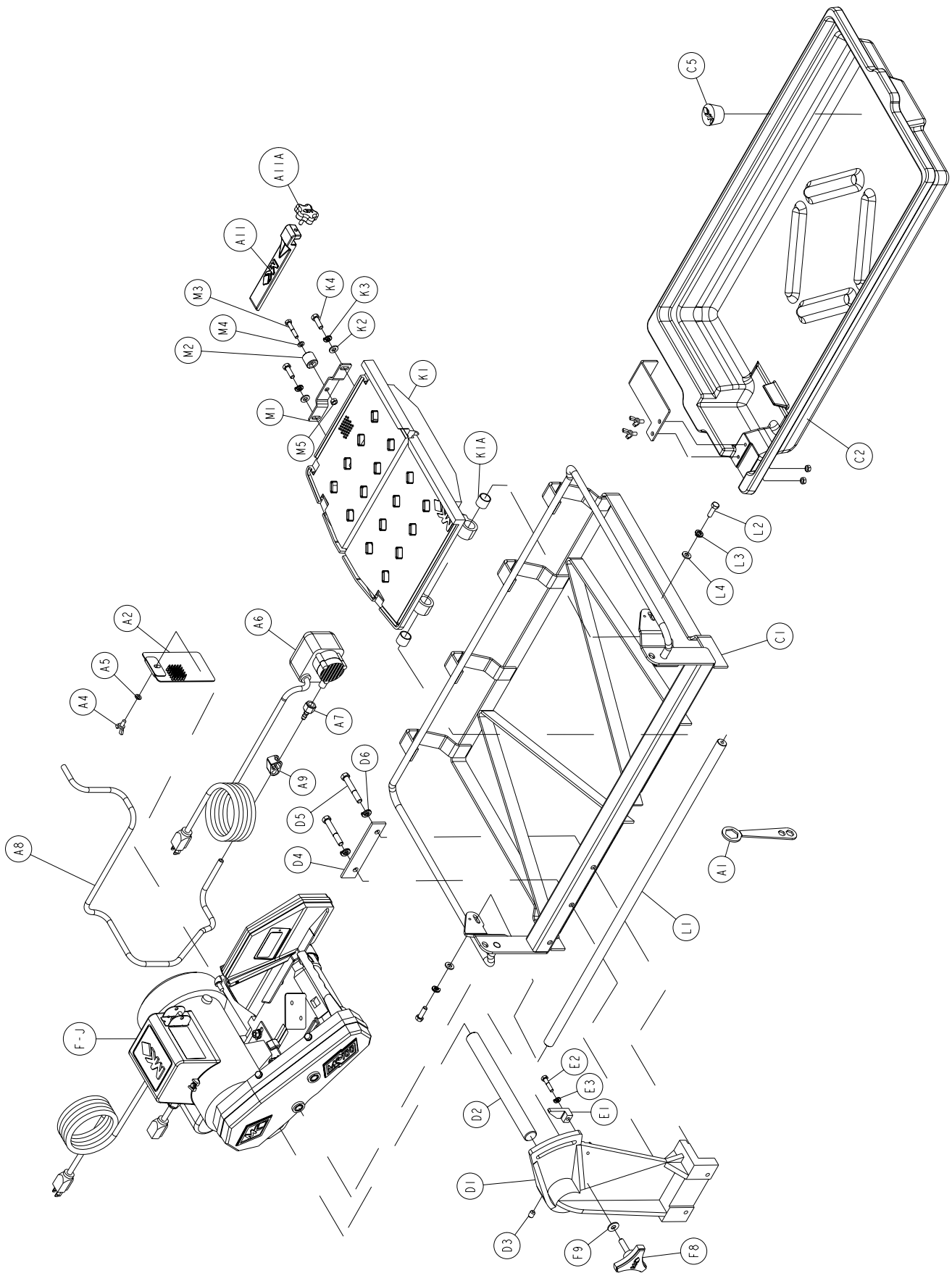

Revision 100	08.2011
Manual Part# 158192	

Caution: Read all safety and operating instructions before using this equipment. This parts list **MUST** accompany the equipment at all times.



Item	Description	Qty	Part#
A	ACCESSORY PACK		N/A
A1	WRENCH, 15/16 CLOSED END	1	134684
A2	CURTAIN, SPLASH	1	160310
A3	BRACKET, SPLASH CURTAIN	1	152571
A4	WINGSCREW, 1/4 - 20 X 1/2	1	151888
A5	WASHER, 1/4 SAE FLAT	1	151915
A6	PUMP, 115V WATER	1	151271
A7	FITTING, PLASTIC, 1/4 FNPT X 1/4 BARB	1	128397
A8	HOSE, VINYL, 1/4 ID	2	132951
A9	CLAMP, FLOW, 1/4 - 1/2	1	154394
A10	OWNER'S MANUAL, WATER PUMP	1	155745
A11	RIP GUIDE	1	159751
A12	BLADE, MK-100, 10 X .060 X 5/8	1	154380
A13	OWNER'S MANUAL, MK-100	1	158192
A14	CARTON, ACCESSORY PACK, 101	1	153366
A15	FOAM, ACCESSORY PACK CARTON	1	154022
A16	CARD, MK WARRANTY REGISTRATION	1	155037
A17	LABEL, DO NOT RETURN	1	157063
B	CARTON		166621
B1	ASSEMBLY, CARTON, MK-100	1	160679
B2	COVER, CARTON, MK-100	1	160679-01
B3	TRAY, CARTON, MK-100	1	160679-02
B4	SUPPORT, CORNER, CARTON, MK-100	6	160679-03
B5	INSERT, CARTON, CUTTING HEAD	1	158542-1
B6	INSERT, CARTON, ACCESSORY PACK	1	158542-2
C-E	ASSEMBLY, FRAME		N/A
C1	FRAME, 101	1	153003
C2	PAN, PLASTIC, 101	1	150634
C3	PIN, 3/16 X 3/8 ROLL (NOT SHOWN)	2	151783
C4	PLATE, ADJUSTMENT OBSOLETE (NOT SHOWN)	2	151758
C5	PLUG, RUBBER DRAIN	1	159529
D	POST		N/A
D1	POST, DC, 101, MK RED	1	158438
D2	SHAFT, 10.63" PIVOT, 101	1	153254
D3	SCREW, 3/8 - 16 X 1/2 SCOKET HEAD SET	1	153710
D4	PLATE, SUPPORT	1	155671
D5	SCREW, 3/8 - 16 X 2-1/2	2	156030
D6	WASHER, 3/8 SPLIT LOCK	2	150925
D7	CASTING POST COVER, PLASTIC	1	160157
E	STOP, CUTTING HEAD		157728-MK
E1	STOP, 10" CUTTING HEAD	1	157728
E2	SCREW, 1/4 - 20 X 10 1/4 HEX HEAD CAP	1	157145
E3	WASHER, 1/4 SPLIT LOCK	1	152591
E4	SHEET, CUTTING HEAD STOP INSTRUCTION	1	157728-IS
F-J	ASSEMBLY, 115V CUTTING HEAD, MK-100	1	158225
F	BELT GUARD	1	N/A
F1	BELT GUARD, MK-100	1	158319-00
F2	BRACKET, INNER BELT GUARD	1	158611
F3	SCREW, 1/4 - 20 X 3/4 HEX HEAD CAP	3	152370
F4	SCREW, 1/4 - 20 X 1 HEX HEAD CAP	1	152676
F5	WASHER, 1/4 SPLIT LOCK	4	152591
F6	WASHER, 1/4 SAE FLAT	4	151915
F7	BELT, 260J6 MICRO-V	1	158194
F8	KNOB, 3/8 - 16 X 1.5 MK ADJUSTMENT	1	156770-2
F9	WASHER, 3/8 SAE FLAT	1	150923

Item	Description	Qty	Part#
G	BLADE GUARD		N/A
G1A	SCREW, HEX HEAD (NOT SHOWN)	1	162473
G1	BLADE GUARD, 110/115	1	162481
G2	ELBOW, 1/8 MNPT X 1/4 BARB 90° BRASS	1	154652
G3	TUBE, WATER	2	155389
G4	SCREW, 5/16 - 18 X 1/2 SOCKET HEAD SET	3	152607
G5	LABEL, TILE SAW SERIAL NUMBER	1	157249-01
H	SUBASSEMBLY, 115V CUTTING HEAD, MK-100	1	158191
H1	HEAD, 10" CUTTING	1	158224
H2	PIN, BLADE SHAFT LOCK	1	158220
H3	SPRING, BLADE GUARD LOCK	1	158201
H4	E-RING, 1/4 RETAINING	2	158202
H5	BEARING, 17MM X 40MM X 12MM BALL (6203 - 2NSSE)	2	137711
H6	SHAFT, BLADE 880/101/108-	1	158222
H7	FLANGE, 2 - 3/8 INNER	1	137737
H8	FLANGE, 2 - 3/8 OUTER	1	135830
H9	NUT, 5/8 18 HEX	1	135848
H10	PULLEY, 6J19 X 5/8 BORE	1	158199
H11	KEY, 3/6 X 3/16 X 1-1/8 WQUARE	1	150344
H12	SCREW, 5/16 - 18 X 3/8 SOCKET HEAD SET, CUP POINT	2	157083
H13	BUMPER, 1/2 DIA. RUBBER	1	152674
H14	SCREW, 5/16 -18 X 1 HEX HEAD CAP	4	151743
H15	WASHER, 5/16 SAE FLAT	4	151754
H16	WASHER, 5/16 SPLIT LOCK	4	151747
H17	NUT, 5/16 - 18 HEX	4	101196
H18	SCREW, 5/16 -18 X 2-1/2 HEX HEAD CAP, FULL THREAD	1	151748
H19	PIVOT, BLADE GUARD	1	153208
H20	WASHER, 3/8 SAE FLAT	2	150923
H21	WINGNUT, 5/16 - 18 NYLOCK	1	151746
H22	STRAP, MOTOR ADJUSTMENT	1	152673
H23	SCREW, 3/8 - 16 X 3 - 1/2 HEX HEAD FULL THREAD	1	153174
J	ASSEMBLY, 1/5HP/115V/60HZ GE MOTOR		N/A
J1	MOTOR, 1/5HP/115V/60HZ GE	1	168022
J2	CASTING, CONDUIT BOX	1	168969
J3	GASKET, CONDUIT BOX/MOTOR	1	158213
J4	SCREW, #12 X 5/8 INDENTEDHEX WASHER SLOTTED B	2	158335
J5	CORD, 14/3 SJTW X 5 - 15P X POWER	1	158205
J6	CORD, 18/3 SJTW X 5 - 15R PUMP	1	158253
J7	SWITCH, 20A DPST TOGGLE, W/QD TERMINALS	1	154310
J8	PLATE, TOGGLE SWITCH LOCKOUT	1	158211
J9	BOOT, TOGGLE SWITCH	1	154301
J10	PULLEY, 6J17 X 5/8 BORE	1	158214
J11	KEY, 3/16 X 3/16 X 1 - 1/8 SQUARE	1	150344
J12	SCREW, 5/16 - 18 X 3/8 SOCKET HEAD SET, CUP POINT	2	157083
J13	LABEL, WARNING, READ OWNER'S MANUAL, 1 - 3/4 X 3 - 3/8	1	155806
J14	LABEL, CAUTION, GFCI, 1 X 2 - 1/8	1	155678
J15	LABEL, CAUTION, 5 AMP MAX, 1 X 2 - 1/8	1	154822
J16	LABEL, MK SERVICE INFORM 2 1/8 X 1 - 13/16	1	155038
J17	SCREW, 10 - 32 X 1 SOCKET HEAD SET, CUP POINT	1	158254
J18	WASHER, #10 INTERNAL TOOTH LOCK	2	158336
J19	TIE, 12 X #10 CLAMP	1	158210
J20	SCREW, 10 - 32 X 1 SOCKET HEAD SET, CUP POINT	2	157083
J21	NUT, 10 - 32 HEX	2	156269
J22	WASHER, 1/2 INTERNAL TOOTH LOCK	1	158337
J23	CAPACITOR, RUN	1	160528
J24	CAPACITOR, START	1	164131
J25	SWITCH, OVERLOAD PROTECTION	1	168105

Item	Description	Qty	Part#
K-M	ASSEMBLY, TABLE		
K	TABLE		
K1	TABLE, 100	1	157660
K1A	BEARING, 3/4 ID MULTILUBE	2	152227
K2	WASHER, 5/16 SAE FLAT	2	151754
K3	WASHER, 5/16 SPLIT LOCK	2	151747
K4	SCREW, 5/16 - 18 X 1 HEX HEAD CAP	2	151743
L	GUIDE BAR		N/A
L1	BAR, 3/4 X 32 GUIDE, 101	1	134759
L2	SCREW, 5/16 - 18 X 1 HEX HEAD CAP	2	151743
L3	WASHER, 5/16 SPLIT LOCK	2	151747
L4	WASHER, 5/16 SAE FLAT	2	151754
M	ASSEMBLY, ROLLER WHEEL		151756
M1	BRACKET, ROLLER WHEEL	1	154021
M2	WHEEL, ROLLER	1	151799
M3	SCREW, 14/ - 20 X 1 - 1/2 HEX HEAD CAP	1	151914
M4	WASHER, 1/4 SAE FLAT	1	151915
M5	NUT, 1/4 - 20 HEX	1	151893

THEORY OF DIAMOND BLADES

Diamond blades do not really cut; they grind the material through friction. Diamond crystals, often visible at the leading edge and sides of the rim/segment, remove material by scratching out particles of hard, dense materials, or by knocking out larger particles of loosely bonded abrasive material. This process eventually cracks or fractures the diamond particle, breaking it down into smaller pieces. As a result, a diamond blade for cutting soft, abrasive material must have a hard metal matrix composition to resist this erosion long enough for the exposed diamonds to be properly utilized. Conversely, a blade for cutting a hard, non-abrasive material must have a soft bond to ensure that it will erode and expose the diamonds embedded in the matrix. These simple principles are the foundation of “controlled bond erosion”



Types of Cutting

There are two basic types of cutting-Dry or Wet. The choice of which type of blade to use depends on:

- The requirements of the job
- The machine/tool utilizing the Diamond Blade
- The preference of the operator

In the case of DRY cutting, the overwhelming popularity and quantity of hand-held saws and the flexible nature of MK Diamond blades to professionally handle most ceramic, masonry, stone and concrete materials, make the DRY cutting blade a very attractive tool. When using a DRY blade, the user must be aware of distinct operating practices to ensure optimum performance. DRY cutting blades require sufficient airflow about the blade to prevent overheating of the steel core. This is best accomplished by shallow, intermittent cuts of the material with periods of “free-spinning” (for several seconds) between each cut, to maximize the cooling process.

For WET cutting applications, MK has the exact blade to compliment both the material to be cut and the wet cutting machine to be used. During cutting operations, liberal amounts of water act as a coolant to support the cutting effectiveness and longevity of the WET blade. Additionally, using water adds to the overall safety of cutting operations by keeping the dust signature down.

KNOW ALL YOU CAN ABOUT THE MATERIAL YOU WISH TO CUT

ITEM	NUMBER	DESCRIPTION	
1.	137166	MK-200, 10 x 5/8 Arbor Premium grade Diamond Blade for smooth, chip-free cutting on tile.	
2.	128074	MK-215, 10 x 5/8 Arbor Supreme grade diamond blade for hard materials	
3.	153252	MK-315, 10 x 5/8 Arbor Supreme super hi-rim diamond blade	
4.	134577-MK	Dual 45° Flat Angle Guide	
5.	153201-MK (large)	45° Bullnose Miter	
6.	134569-MK	90° Protractor	
7.	152792	Dressing Stone	
8.	152610	Ground Fault Circuit Interrupter	
9.	151889	Stand for 10" Tile Saw	

ORDERING INFORMATION

You may order MK Diamond products through your local MK Diamond distributor or, you may order direct from MK Diamond.

NOTE: There is a \$25.00 minimum order when ordering direct from MK Diamond. All purchases must be made using VISA, MasterCard or American Express.

When ordering direct from MK Diamond, please have the following information ready before calling:

- The Model Number of the saw
- The Serial Number of the saw
- Where the saw was purchased and when
- The Part Number for the part(s) being ordered
- The Part Description for the part(s) being ordered

All parts may be ordered by calling toll free to – (800) 421-5830 or (310) 539-5221 and asking for Customer Service. For technical questions, call – (800) 474-5594.

RETURN MATERIALS POLICY

To expedite the service relative to the return of a product purchased through MK Diamond, please observe the following:

NOTE: When returning all items, they must have been purchased within the previous twelve (12) months.

- Have the Model Number of the saw
- Have the Serial Number of the saw
- Have the location of where the saw was purchased
- Have the date when the saw was purchased
- Contact Customer Service for approval to return the item(s)
- Obtain a Returned Goods Number (RGA) authorizing the return
- Follow the packaging instructions in the following section
- Ensure your item(s) are prepaid to the destination

For returned items, call toll free to – (800) 421-5830 or (310) 539-5221 and ask for Customer Service. For technical questions, call – (800) 474-5594 or (310) 257-2845.

PACKAGING INSTRUCTIONS

- Remove the Blade guard and Support Angle Assembly
- Dry the saw before shipping
- When packing, include the following: MK-100, Diamond Blade, Blade guard and Support Angle Assembly and Adjustable Cutting Guide (Other Accessories are not required)
- Package the unit in its original container or one of comparable size (do not ship the unit partially exposed)
- Ensure all parts are secured in the packaging to prevent moving

AUTHORIZED SERVICE CENTERS

For quicker repair time, you may contact MK Diamond Customer Service, toll free, at (800) 421-5830 or (310) 539-5221 for the Authorized Service Center closest to you or visit our web site at www.mkdiamond.com. For technical questions, call – (800) 474-5594.

MK-100 TILE SAW
OWNER'S MANUAL & OPERATING INSTRUCTIONS



MK Diamond Products, Inc.

MK Diamond Products, Inc.
1315 Storm Parkway
Torrance, CA 90501

Toll-Free: (800) 421-5830
Phone: (310) 539-5221
Fax: (310) 539-5158
www.mkdiamond.com