

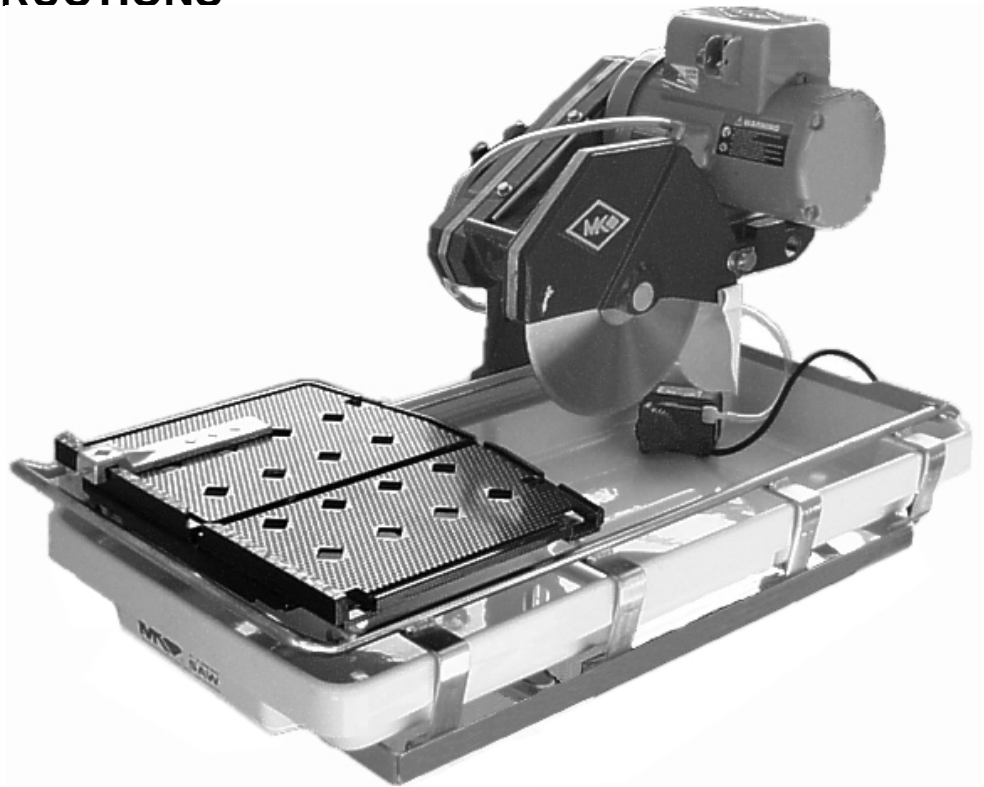

# MK-101 TRACKER

**TILE SAW  
OWNER'S MANUAL &  
OPERATING INSTRUCTIONS**



**CAUTION:**  
Read all safety and  
operating instructions  
before using this  
equipment

Enter the Serial Number of your new saw in the  
space below. The Serial Number is located on the  
left side of the blade guard.

**SERIAL NUMBER:**

**NOTE:**

For your (1) one year warranty to be effective,  
complete the warranty card (including the Serial  
Number and mail it in as soon as possible.

## INTRODUCTION

We at MK Diamond want to congratulate you on selecting the MK-101 TRACKER Tile Saw. We are certain that you will be pleased with your purchase. MK Diamond takes pride in producing the finest products in the industry.

Operated correctly, your MK-101 TRACKER should provide you with years of quality service. In order to help you, we have included this manual. This owner's manual contains information necessary to operate and maintain your MK-101 TRACKER safely and correctly. Please take a few minutes to familiarize yourself with the MK-101 TRACKER by reading and reviewing this manual.

If you should have questions concerning your MK-101 TRACKER, please feel free to call our friendly customer service department at: 800 421-5830

Regards,

MK Diamond

# TABLE OF CONTENTS

	<b>Page</b>
<b>SAFETY:</b>	4
Safety Messages	4
Damage Prevention Message	4
General Safety Precautions and Hazard Symbols	4
California Proposition 65 Message	6
Electrical Requirements and Grounding Instructions	7
Safety Label Locations	9
Tile Saw Specific Warnings	9
Product Specifications	10
<b>UNPACKING, TRANSPORT, UNIVERSAL STAND, and ASSEMBLY</b>	
Unpacking	11
Contents	11
Transport	11
Universal Stand	12
Assembly	13
<b>SETUP, ADJUSTMENT AND OPERATION</b>	
Setup	15
Adjustment and Operation	18
Cleanup	24
<b>MAINTENANCE AND TROUBLESHOOTING</b>	
Maintenance	26
Troubleshooting	33
<b>EXPLODED VIEW AND PARTS LIST</b>	
Exploded View	37
Parts List	39
<b>THEORY</b>	
Theory of Diamond Saws	42
<b>ACCESSORIES</b>	
Accessories	43
<b>ORDERING and RETURN INSTRUCTIONS</b>	
Ordering Information	44
Return Material Policy	44
Packaging Instructions	44
Authorized Service Centers	44

## SAFETY

Read and follow all safety, operating and maintenance instructions. Failure to read and follow these instructions could result in injury or death to you or others. Failure to read and follow these instructions could also result in damage and/or reduced equipment life.

### **SAFETY MESSAGES:**

Safety messages inform the user about potential hazards that could lead to injury, death and/or equipment damage. Each safety message will be preceded by one of the following (3) three words that identify the severity of the message.

#### **▲ DANGER**

Not following instructions **WILL** lead to **DEATH** or **SERIOUS INJURY**

#### **▲ WARNING**

Not following instructions **COULD** lead to **DEATH** or **SERIOUS INJURY**

#### **▲ CAUTION**

Not following instructions **CAN** lead to injury

### **DAMAGE PREVENTION AND INFORMATION MESSAGES:**

A Damage Prevention Message is to inform the user of important information and/or instructions that could lead to equipment or other property damage if not followed. Information Messages convey information that pertains to the equipment being used. Each message will be preceded by the word NOTE, as in the example below.

#### NOTE:

Equipment and/or property damage may result if these instructions are not followed.

### **GENERAL SAFETY PRECAUTIONS AND HAZARD SYMBOLS:**

In order to prevent injury, the following safety precautions and symbols should be followed at all times!

#### **Safety Precautions:**

##### KEEP GUARDS IN PLACE.



In order to prevent injury, keep guards in place and in working order at all times.

##### REMOVE ADJUSTING KEYS AND WRENCHES.

Form a habit of checking to see that keys and adjusting wrenches are removed from the power tool before it is turned on.

##### KEEP WORK AREA CLEAN.

Cluttered work areas and benches invite accidents.

##### DO NOT USE IN DANGEROUS ENVIRONMENTS.

Do not use power tools in damp or wet locations nor expose them to rain. Always keep the work area well lighted.

##### KEEP CHILDREN AWAY.

All visitors and children should be kept a safe distance from work area.

##### MAKE THE WORKSHOP KID PROOF.

Make the workshops kid proof by using padlocks, master switches or by removing starter keys.

##### DO NOT FORCE THE TOOL.

A power tool will do a job better and safer operating at the rate for which it was designed.

##### USE THE RIGHT TOOL.

Do not force a tool or an attachment, to do a job that it was not designed to do.

## SAFETY

### USE THE PROPER EXTENSION CORD.

If using an extension cord, make sure it is in good condition first. When using an extension cord, be sure to use one heavy enough to carry the current your product will draw. An undersized cord will cause a drop in line voltage that will result in a loss of power and overheating. TABLE 1, Page 7 shows the correct AWG size to use depending on cord length and nameplate ampere rating. If in doubt, use the next heavier gage. The smaller the gage number, the heavier the cord.

### WEAR PROPER APPAREL.

Do not wear loose clothing, gloves, neckties, rings, bracelets, or other jewelry that may be caught in moving parts. Non-slip footwear is recommended. Wear protective hair covering to contain long hair.

### ALWAYS USE SAFETY GLASSES.



Safety glasses should always be worn when working around power tools. In addition, a face, dust mask or respirator should be worn if a cutting operation is dusty. Everyday eyeglasses only have impact resistant lenses and may not prevent eye injury; they are NOT safety glasses.

### SECURE WORK.

Clamps or a vise should be used to hold work whenever practical. Keeping your hands free to operate a power tool is safer.

### DO NOT OVERREACH.

Keep proper footing and balance at all times by not overreaching.

### MAINTAIN TOOLS WITH CARE.

Keep tools clean for the best and safest performance. Always follow maintenance instructions for lubricating, and when changing accessories.

### DISCONNECT TOOLS.

Power tools should always be disconnected before servicing or when changing accessories, such as blades, bits, cutters, and the like.

### REDUCE THE RISK OF UNINTENTIONAL STARTING.



Make sure the switch is in the OFF position before plugging in the saw.

### USE RECOMMENDED ACCESSORIES.

Consult the owner's manual for recommended accessories. Using improper accessories may increase the risk of personal or by-stander injury.

### NEVER STAND ON THE TOOL.

Serious injury could occur if a power tool is tipped, or if a cutting tool is unintentionally contacted.

### CHECK FOR DAMAGED PARTS.

Before using a power tool, check for damaged parts. A guard or any other part that is damaged should be carefully checked to determine it would operate properly and perform its intended function. Always check moving parts for proper alignment or binding. Check for broken parts and mountings and all other conditions that may affect the operation of the power tool. A guard, or any damaged part, should be properly repaired or replaced.

### DIRECTION OF FEED.

Always feed work into a blade or cutter against the direction of rotation. A blade or cutter should always be installed such that rotation is in the direction of the arrow imprinted on the side of the blade or cutter.

### NEVER LEAVE A TOOL RUNNING UNATTENDED – TURN POWER OFF.

Do not leave a tool until it comes to a complete stop. Always turn a power tool OFF when leaving the work area, or, when a cut is finished.

## SAFETY

### Hazard Symbols:

#### ELECTRICAL SHOCK!



Never touch electrical wires or components while the motor is running. Exposed, frayed or worn electrical motor wiring can be sources of electrical shock that could cause severe injury or burns.

#### ACCIDENTAL STARTS!



Make sure the switch is in the OFF position before plugging in the saw.

#### ROTATING OR MOVING PARTS!



Keep hands, feet, hair, and clothing away from all moving parts to prevent injury. Never operate a power tool with covers, shrouds, or guards removed.

#### **▲WARNING**

Sawing and drilling generates dust. Excessive airborne particles may cause irritation to eyes, skin and respiratory tract. To avoid breathing impairment, always employ dust controls and protection suitable to the material being sawed or drilled; See OSHA (29 CFR Part 1910.1200). Diamond Blades improperly used are dangerous. Comply with American National Standards Institute Safety Code, B7.1 and, Occupational Safety and Health Act covering Speed, Safety Guards, Flanges, Mounting Procedures, General Operating Rules, Handling, Storage and General Machine Conditions.

### **CALIFORNIA PROPOSITION 65 MESSAGE:**

---

#### **▲WARNING**

Some dust created by power sanding, sawing, grinding, drilling, and other construction activities contain chemicals known [to the State of California] to cause cancer, birth defects or other reproductive harm. Some examples of these chemicals are:

- Lead, from lead-based paints
- Crystalline silica, from bricks and cement and other masonry products
- Arsenic and chromium, from chemically treated lumber

For further information, consult the following sources:

<http://www.osha-slc.gov/sltc/silicacrystalline/index.html>

[http://www.oehha.org/prop65/out\\_of\\_date/6022kLstA.html](http://www.oehha.org/prop65/out_of_date/6022kLstA.html)

Your risk from these exposures varies depending on how often you do this type of work. To reduce your exposure to these chemicals, work in a well-ventilated area, and work with approved safety equipment, such as those dust masks that are specially designed to filter out microscopic particles.

## SAFETY

### ELECTRICAL REQUIREMENTS AND GROUNDING INSTRUCTIONS:

In order to prevent potential electrical shock and injury, the following electrical safety precautions and symbols should be followed at all times!

#### ⚠ WARNING



In case of a malfunction or breakdown, grounding provides a path of least resistance for electric current to reduce the risk of electric shock. This tool is equipped with an electric cord having an equipment-grounding conductor and a grounding plug. The plug must be plugged into a matching outlet that is properly installed and grounded in accordance with all local codes and ordinances.

- Do not modify the plug provided – if it will not fit the outlet; have the proper outlet installed by a qualified electrician
- Improper connections of the equipment-grounding conductor can result in a risk of electric shock. The equipment-grounding conductor is the insulated conductor that has an outer surface that is green, with or without yellow stripes. If repair or replacement of the electric cord or plug is necessary, do not connect the equipment-grounding conductor to a live terminal
- Check with a qualified electrician or service personnel if the grounding instructions are not completely understood, or if in doubt as to whether the tool is properly grounded
- Use only 3-wire extension cords that have 3-prong grounding plugs and 3-pole receptacles that accept the tool's plug
- Repair or replace a damaged or worn cord immediately

⚠ WARNING This tool is intended for use on a circuit that has an outlet that looks like the one shown in Sketch A of Figure 1. The tool has a grounding plug that looks like the plug illustrated in Sketch A of Figure 1. A temporary adapter, which looks like the adapter illustrated in sketches B and C,

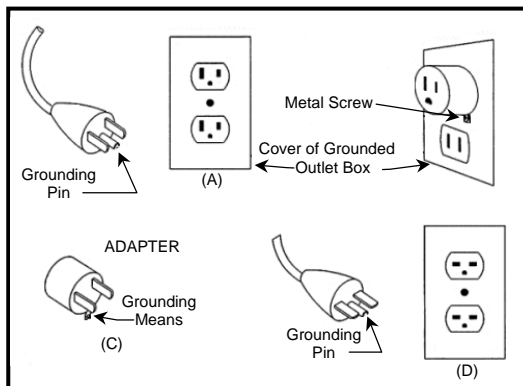

may be used to connect this plug to a 2-pole receptacle as shown in Sketch B, if a properly grounded outlet is not available. The temporary adapter should be used only until a properly grounded outlet can be installed by a qualified electrician. The green-colored rigid ear, lug, and the like, extending from the adapter, must be connected to a permanent ground such as a properly grounded outlet box.

NOTE: Use of a temporary adapter is not permitted in Canada.

FIGURE 1

⚠ WARNING To reduce the risk of electrocution, keep all connections dry and off the ground.



A Ground Fault Circuit Interrupter (GFCI) should be provided on the circuit(s) or outlet(s) to be used for the Saw. Receptacles are available having built-in GFCI protections and may be used for this measure of safety.

When using an extension cord, the GFCI should be installed closest to the power source, followed by the extension cord and lastly, the saw.

⚠ WARNING The pump requires a GFCI. To reduce risk of electric shock when operating the saw with the pump plugged into the 3-pole receptacle on the motor, connect the saw to a GFCI outlet. See the pump manual and informational tags enclosed separately for all pump information.

⚠ CAUTION Shock Hazard. For replacement, use only an identical MK pump, model PE1 part #151271.

NOTE: Do not run the pump dry. Also, be sure to disconnect and remove the pump when cutting dry.

# SAFETY

**⚠ WARNING**

When using the water pump plugged into the water pump receptacle, the saw must be plugged into a properly installed and grounded GFCI outlet See Sketch A of Figure 2. If a GFCI outlet is not available, MK Diamond has available as an accessory item, a plug-in GFCI that may be plugged into a properly installed and grounded 3-pole outlet. See Sketch A of Figure 2.

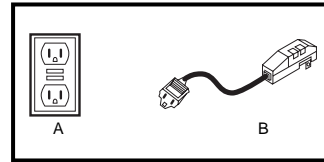

FIGURE 2

**⚠ WARNING**



To avoid the possibility of the appliance plug or receptacle getting wet, position the saw to one side of a wall mounted receptacle. This will prevent water from dripping onto the receptacle or plug. A "drip loop," shown in Figure 3, should be arranged by the user to properly position the power cord relative to the power source.

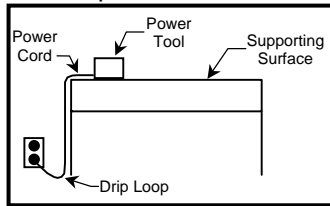

FIGURE 3

The "drip loop" is that part of the cord below the level of the receptacle, or the connector, if an extension cord is used. This method of positioning the cord prevents the travel of water along the power cord and coming in contact with the receptacle.

If the plug or receptacle gets wet, DO NOT unplug the cord. Disconnect the fuse or circuit breaker that supplies power to the tool. Then unplug and examine for presence of water in the receptacle.

**⚠ WARNING**



Use only extensions cords that are intended for outdoor use. These extension cords are identified by a marking "Acceptable for use with outdoor appliances; store indoors while not in use." Use only extension cords having an electrical rating not less than the rating of the product. Do not use damaged extension cords. Examine extension cords before using and replace if damaged. Do not abuse extension cords and do not yank on any cord to disconnect. Keep cords away from heat and sharp edges. Always disconnect the extension cord from the receptacle before disconnection the product form the extension cord.

To reduce the risk of electrocution, keep all connections dry and off the ground. Do not touch the plug with wet hands.

**⚠ WARNING**



Use of undersize extension cords result in low voltage to the motor that can result in motor burnout and premature failure. MK Diamond warns that equipment returned to us showing signs of being run in a low voltage condition, through the use of undersized extension cords will be repaired or replaced totally at the customer's expense. There will be no warranty claim.

To choose the proper extension cord,

- Locate the length of extension cord needed in TABLE 1 below.

Once the proper length is found, move down the column to obtain the correct AWG size required for that length of extension cord.

**Extension Cord Minimum Gage for Length**

Volts	Total Length of Cord in Feet			
	25 ft.	50 ft.	100 ft	150 ft.
120V	AWG 14	AWG 12	AWG Not Recommended	AWG

TABLE 1

**LOCK OUT METHOD:**

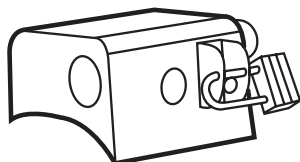

In order to help prevent accidental starting and to help make your workshop "Kidproof," this saw is provided with a means to deactivate the functioning of the motor switch. The switch is equipped with a Lockout plate that can be used with a lock to prevent the movement of the toggle switch. With the toggle switch unable to move the motor cannot be turned on. Removing the lock reactivates the switch.



# SAFETY

## SAFETY LABEL LOCATIONS:

Safety labels are located according to Figures 1 through 4 below. The labels contain important safety information. Please read the information contained on each safety label. These labels are considered a permanent part of your saw. If a label comes off or becomes hard to read, contact MK Diamond or your dealer for a replacement

Item	Location	Description	Part No.
1.	Motor Front	Warning Read and Follow Operating Instructions	155806
2A.	Motor Side	Caution Receptacle for Pump Only	154822
2A.	Blade Side	Saw Serial Number Specifications	157249-01
3A	Motor Rear	Service or Warranty Information	155038
3B	Motor Rear	Extension Cord Warnings	155038
3C	Motor Rear	Motor Specifications	N/A
4A	Pump Left Side	Warning Connect to Grounded Receptacle	N/A
4B	Pump Right Side	Pump Specifications	N/A

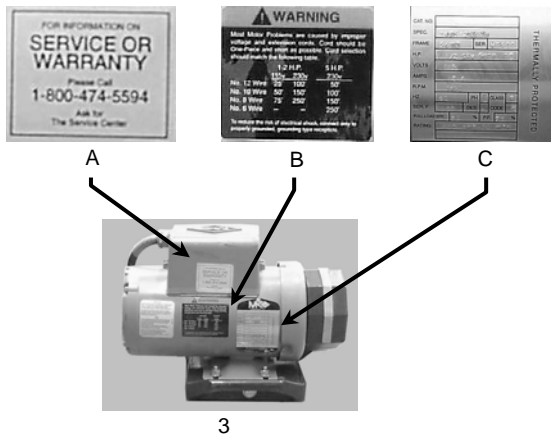
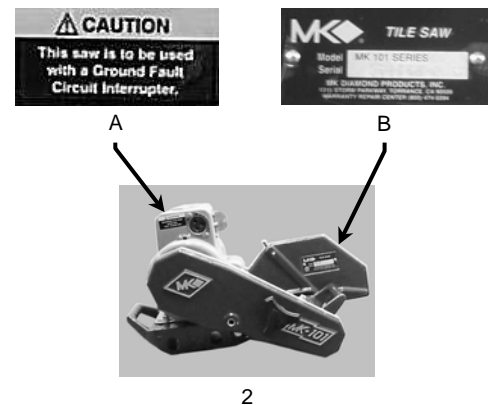

## TILE SAW SPECIFIC WARNINGS:

### ⚠️WARNING

Wear eye protection.

Disconnect saw before servicing, when changing cutting blades, and cleaning.

Use tool only with smooth edge cutting blades free of openings and grooves.

Replace damaged cutting blade before operating.

## SAFETY

### PRODUCT SPECIFICATIONS:

The MK-101 TRACKER is a versatile Tile Saw. Operated and used according to this manual, the MK-101 TRACKER will provide years of dependable service.

#### General Description:

The MK-101 TRACKER Tile Saw is engineered as a tabletop or stand mounted wet tile saw. The saw includes a powerful 115v totally enclosed capacitor start Baldor motor with a thermal protective overload. The saw is capable of cutting tile up to twenty (20) inches in length, or diagonal cutting tile up to fourteen (14) inches. The saw can cut an object three and one-half (3-1/2) inches thick in one pass.

#### Motor Specifications:

Motor specifications for the MK-101 TRACKER are listed in Table 2 below.

Voltage	115 v
Overall Amperage	13 a
Motor Only Amperage	12.4 a
Frequency	60 Hz
RPM	3450 rpm
Horse Power	1.5 hp
Weight	107 lbs

Table 2

#### Thermal Overload Protection:

The motor is protected by a thermal overload equipped with a manual reset.

#### Blade Capacity:

The MK-101 TRACKER uses a ten (10) inch (254mm) diameter, wet cutting continuous rim, MK Diamond blade with a one-sixteenth 1/16 inch (1.5875 mm) cutting width and a five-eighths (5/8) inch (15.875 mm) arbor.

#### Tile Types:

The MK-101 TRACKER can cut a variety of tile types including Porcelain, Terracotta, Marble, Quarry and Slate, or almost any other non-ferrous material.

#### NOTE:

The MK-101 TRACKER is not designed to cut plastic or ferrous (metals) material.

# UNPACKING, TRANSPORT, UNIVERSAL STAND and ASSEMBLY

## UNPACKING:

Your MK-101 TRACKER has been shipped from the factory thoroughly inspected. Only minimal assembly is required.

**CAUTION** Use proper lifting techniques when lifting the MK-101 TRACKER.

## CONTENTS:

In your container, you will find one (1) MK-101 TRACKER frame and water basin, one (1) MK-101 TRACKER Cutting Head, one (1) MK-101 TRACKER removable cutting table, one (1) 10-inch wet cutting continuous rim diamond blade, one (1) adjustable cutting guide, one (1) electric water pump, one (1) pump discharge fitting, one (1) cooling transfer tube, one (1) flow adjusting clamp, one (1) drain plug, one (1) blade wrench, one (1) splash guard, one (1) owners manual, one (1) pump manual and one (1) warranty card.



MK-101 TRACKER  
Frame  
and Water Basin



MK-101 TRACKER  
Cutting Head

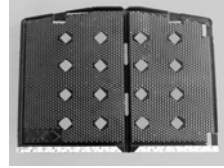

Removable Cutting  
Table



Diamond Blade

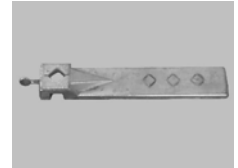

Adjustable  
Cutting Guide



Electric  
Water Pump



Pump  
Discharge Fitting



Cooling  
Transfer Tube



Flow  
Adjusting Clamp



Drain Plug



Wrench



Splash  
Guard



Owners  
Manual



Pump  
Manual



Warranty  
Card

## TRANSPORT:

- CAUTION**
1. The MK-101 TRACKER weighs approximately one hundred and seven (107) pounds.
  2. Never transport the MK-101 TRACKER with water in the Water Basin.

The MK-101 TRACKER is designed with a rigid frame removable Cutting Head and Cutting Table. Two people are required to transport the MK-101 TRACKER with the Cutting Head installed. Remove the Cutting Table before transport. Remove the Cutting Head if one person is transporting the saw (see Cutting Head Installation and Removal in the following section).

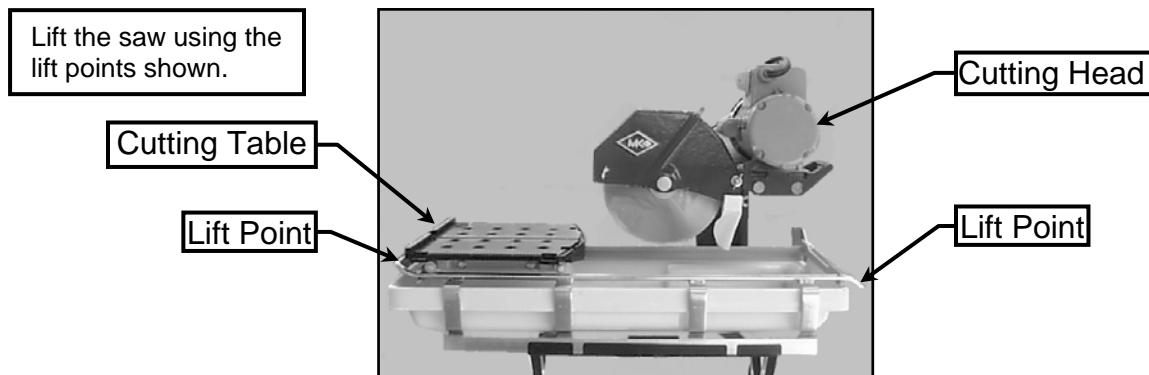

# UNPACKING, TRANSPORT, UNIVERSAL STAND and ASSEMBLY

## UNIVERSAL STAND:

**CAUTION** The MK-101 TRACKER weighs approximately one hundred and seven (107) pounds; follow the guidelines for transport in the TRANSPORT section, when placing it on the stand.

Note: If using the MK Diamond, Universal Stand, follow the following steps.

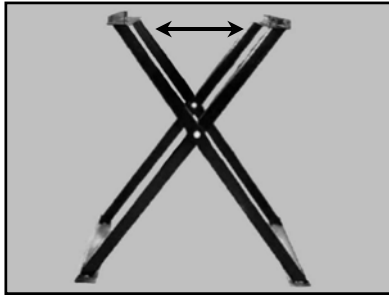

(A)  
Open the Universal Stand  
and place on flat surface

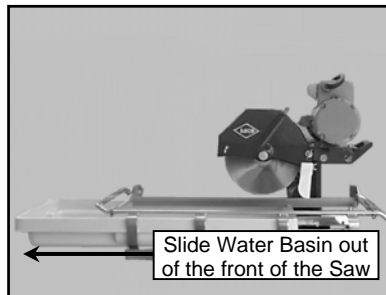

(B)  
Remove Water Basin

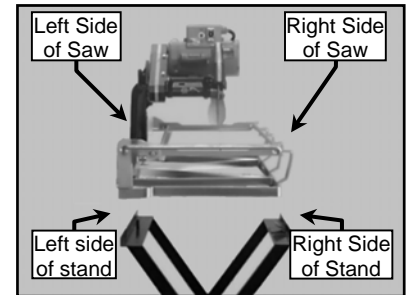

(C)  
Orient the Saw  
to the Stand

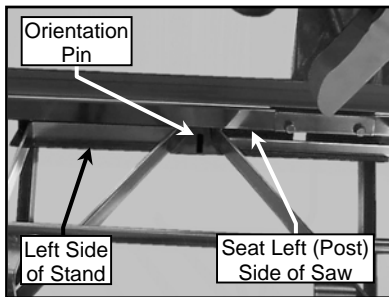

(D)  
Seat Left (Post) Side of saw  
onto stand between stand  
Orientation Pin

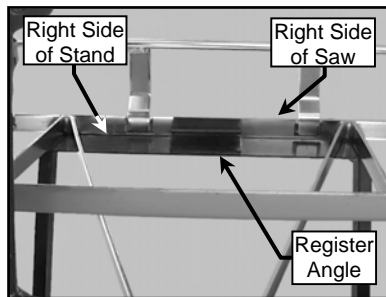

(E)  
Seat Right Side of saw onto  
stand between stand and  
Register Angle

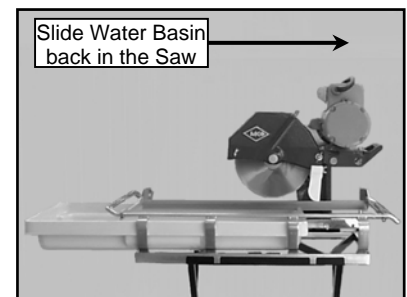

(F)  
Reinstall the Water Basin

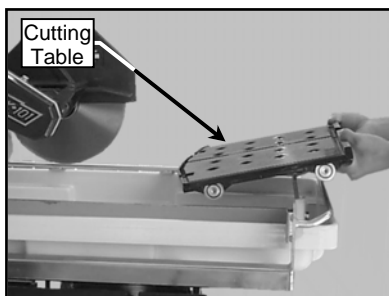

(G)  
Install the Cutting Table  
(See Cutting Table Installation)

# UNPACKING, TRANSPORT, UNIVERSAL STAND and ASSEMBLY

## ASSEMBLY:

Follow the assembly instructions to prepare your MK-101 TRACKER for operation.

### 1. Diamond Blade Installation:

NOTE: When installing the Retaining Screw, do not "cross-thread" and DO NOT over tighten the screw.

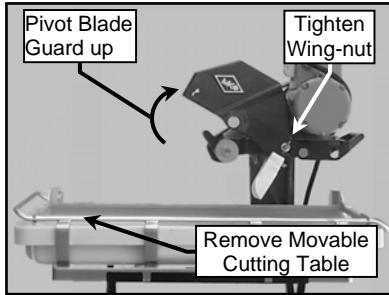

(A)

Remove the Movable Cutting Table from the saw and raise the Blade Guard

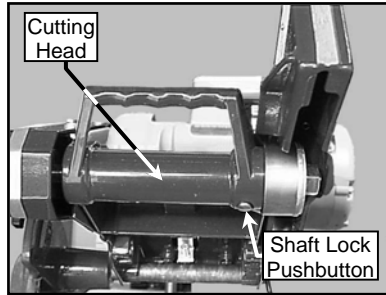

(B)

Locate the Shaft Lock pushbutton on the underside of the Cutting Head

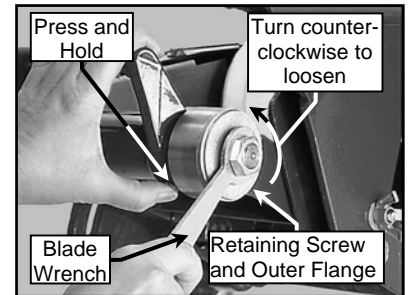

(C)

Depress and hold the Shaft Lock pushbutton and remove Retaining Screw and Outer Flange using the Blade Wrench

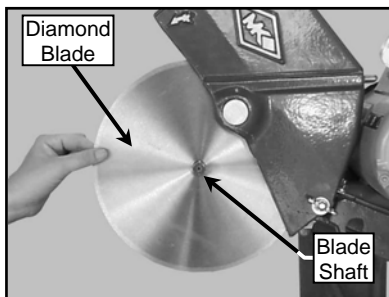

(D)

Install Diamond Blade onto Blade Shaft

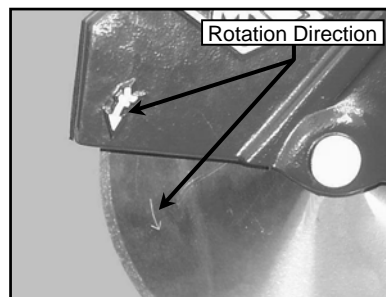

(E)

Verify the Blade is seated on the Blade Shaft and direction of rotation is correct

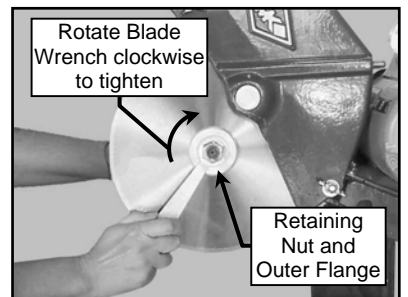

(F)

Install Retaining Nut and Outer Flange, depress and hold the Shaft Lock pushbutton and Tighten

### 2. Movable Cutting Table Installation:

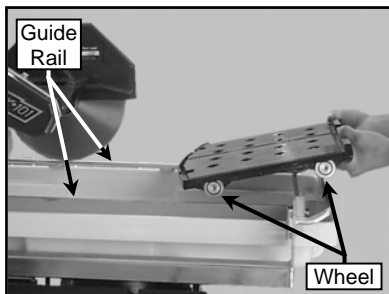

(A)

Align the four (4) wheels of the Movable Cutting Table to the saw Guide Rails

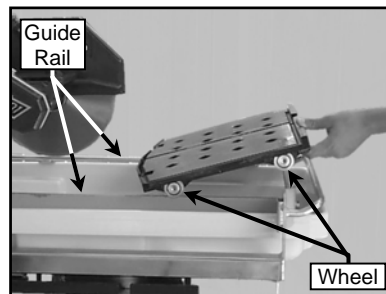

(B)

Seat all four (4) wheels onto the Guide Rails

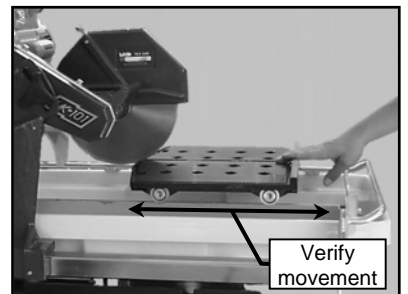

(C)

Verify movement of the Movable Cutting Table

## UNPACKING, TRANSPORT, UNIVERSAL STAND and ASSEMBLY

### 3. Adjustable Cutting Guide Installation:

NOTE: The Adjustable Cutting Guide can be used on either side of the Diamond Blade.

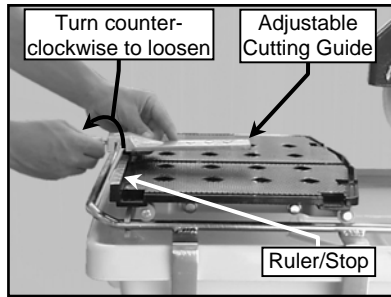

(A)

Loosen Adjustable Cutting Guide retaining thumbscrew and place it over the Movable Cutting Table Ruler/Stop

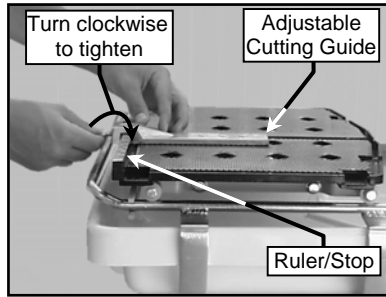

(B)

Place the Adjustable Cutting Guide onto the Movable Cutting Table Ruler/Stop and tighten the retaining thumbscrew

### 4. Splash Guard Installation:

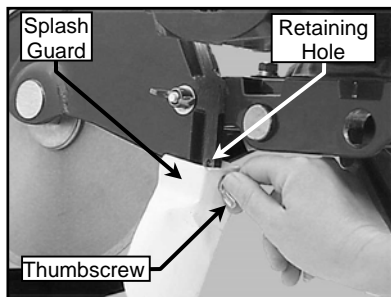

(A)

Install the retaining thumbscrew through the washer and Splash Guard then align to the hole found on back of the Blade Guard

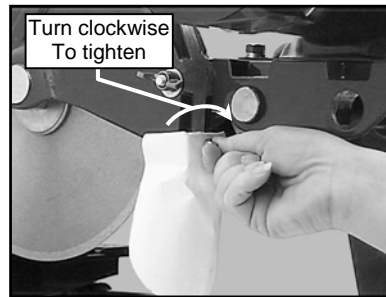

(B)

Install the Splash Guard onto the Blade Guard

### 5. Water Pump Preparation:

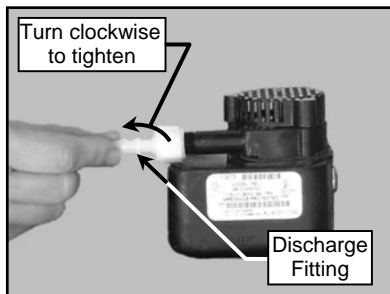

(A)

Install Water Pump Discharge Fitting

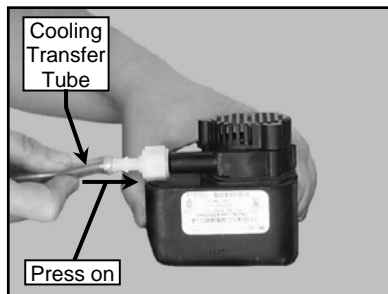

(B)

Press one end of the Cooling Transfer Tube onto the Water Pump Discharge Fitting

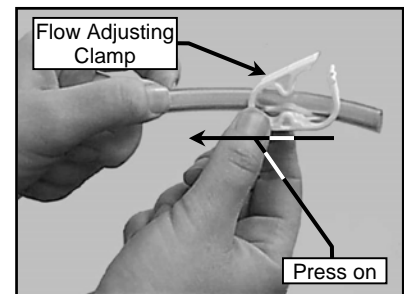

(C)

Slide Cooling Flow Adjusting Clamp onto the Cooling Transfer Tube

# SETUP, ADJUSTMENT and OPERATION

## SETUP:

### 1. Pre-start Inspection:

Prior to beginning work, a pre-start inspection of the saw should be performed.

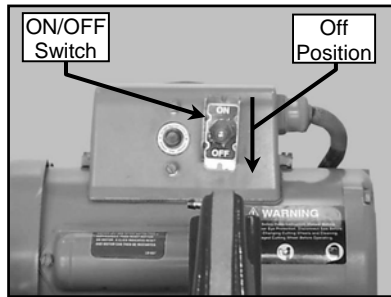

(A)  
Ensure the ON/OFF Switch is in the OFF position

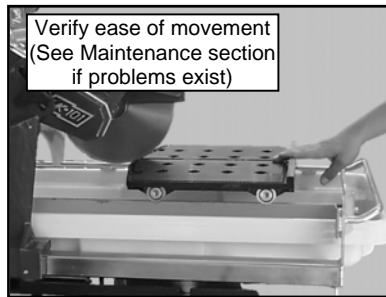

(B)  
Verify the Movable Cutting Table moves freely

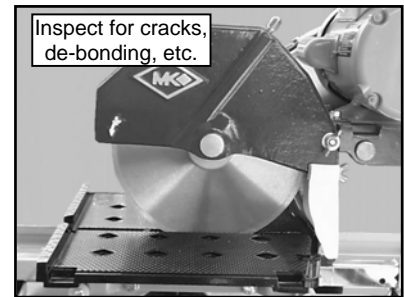

(C)  
Inspect the Diamond Blade for damage – verify the blade is correct for the material being cut

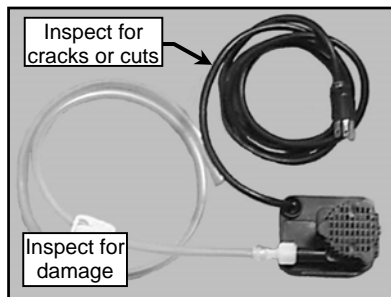

(D)  
Inspect the Pump Assembly for damage – ensure the cord is free of cracks or cuts

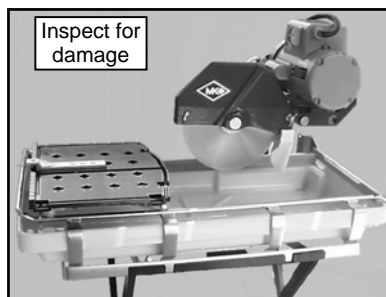

(E)  
Inspect the MK-101 TRACKER for damage – ensure the cord is free of cracks or cuts

### 2. Connecting the Water Pump:

- ⚠ WARNING 1.** To prevent the possibility of electrical shock, the MK-101 TRACKER **MUST** be de-energized when connecting the Water Pump.
- 2.** To prevent the possibility of electrical shock, use only MK Diamond qualified replacement parts

**NOTE:** To prevent pump damage, the Water Pump must be disconnected if cutting with a Dry Blade.

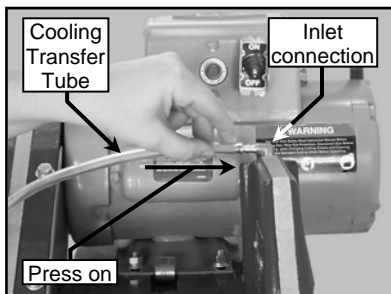

(A)  
Connect the Cooling Transfer Tube to the inlet connection of the Blade Guard

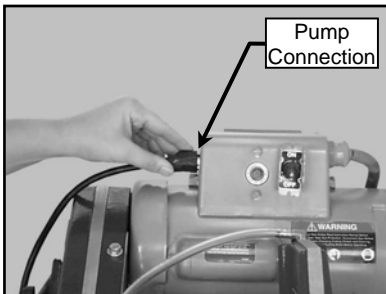

(B)  
Connect the Water Pump power cord to the connection found on the back of the motor

## SETUP, ADJUSTMENT and OPERATION

### 3. Water Pump Setup for Operation:

The Water Pump can be setup for operation in two ways, External Water Source or Re-circulation.

NOTE: If using a dry blade for operation, DO NOT connect the water pump.

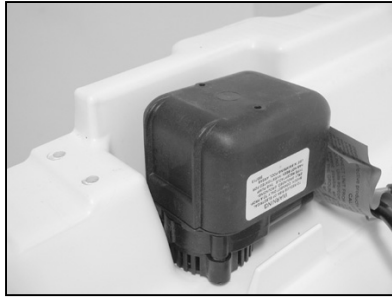

(A)  
Place Water Pump in Water Pan



(B)  
Place Water Pump Clamp as shown



(C)  
Secure Clamp with ¼-20 wingscrews and nuts.

#### I. External Water Source:

This is the preferred method of cooling.

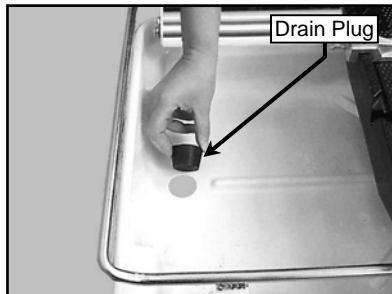

(A)  
Remove the Drain plug

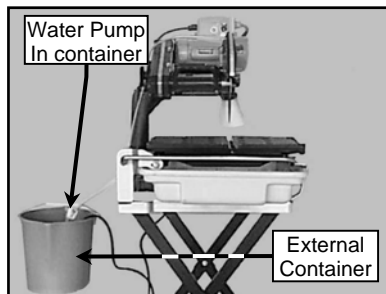

(B)  
Place the Water Pump In an external container

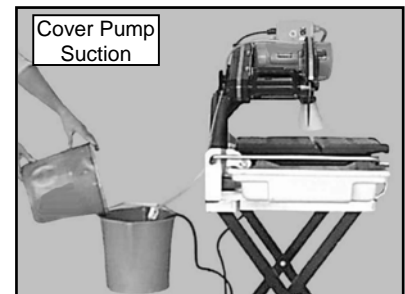

(C)  
Fill the external container until water completely covers the Water Pump suction

#### II. Re-circulation:

NOTE: When using the re-circulation method, the water should be changed often for longer pump life.

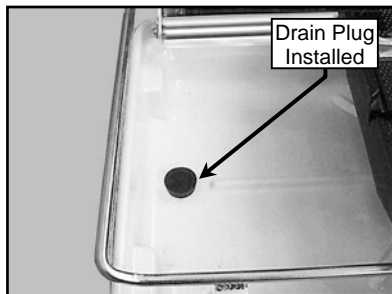

(A)  
Ensure the Drain Plug is Installed in the Water Basin

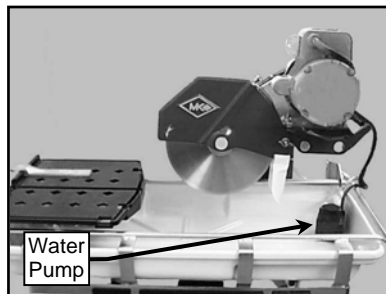

(B)  
Place the Water Pump in the back of the Water Basin.

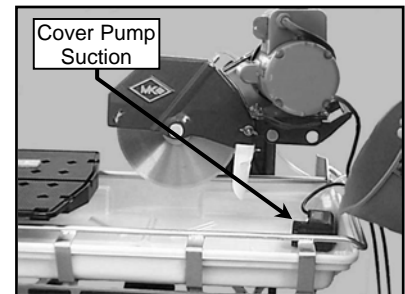

(C)  
Fill the Water Basin until water completely covers the Water Pump suction



# SETUP, ADJUSTMENT and OPERATION

## 4 MK-101 TRACKER Setup for Operation:

- ⚠CAUTION** 1. Before powering or starting, check for damage that could prevent this equipment from proper operation or performing its intended function. Check for binding and alignment of moving parts. Check for damaged, broken, or missing parts.
2. Verify the On/Off switch is in the OFF position.
3. Before connecting the MK-101 TRACKER to a power supply, be sure the voltage, cycle and phase of the job site power source meet the requirements of TABLE 3

VOLTAGE:	115v
CYCLE:	60hz
PHASE:	1-phase

TABLE 3

4. If using an extension power cord, made sure, the length and wire gauge correspond to the requirements listed in TABLE 1 on page 9. An extension power cord that is too small in wire gauge (diameter), or too long in length, will cause the motor to overheat and could cause premature failure.
5. Use an approved Ground Fault Circuit Interrupter (GFCI)
6. Do not cover the motor vents as this could lead to motor overheating.

NOTE: In order to avoid breaker tripping, a 20-amp circuit breaker should be used.

### Portable Generator:

If using a portable generator, ensure the generator meets the following minimum requirements:

5 KW

120/240 volts

41.7/20.8 amps

Single Phase

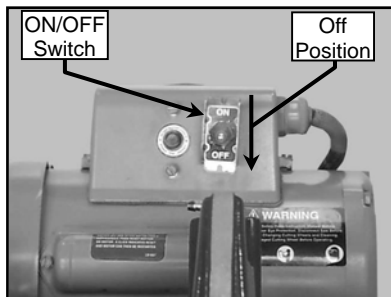

(A)  
Ensure the ON/OFF Switch is in the OFF position

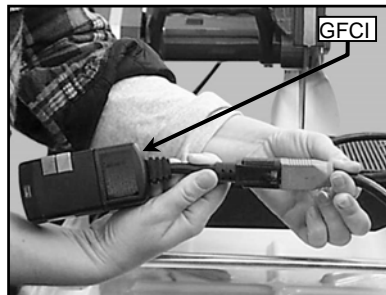

(B)  
Plug MK-101 TRACKER into the GFCI

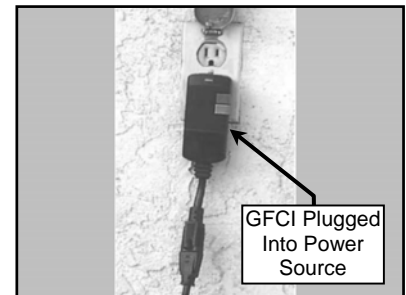

(C)  
Plug the GFCI into the Power source \*

## 5. Set Cutting Depth:

**⚠CAUTION** When loosening the Cutting Head Adjusting Knob, the Cutting Head will pivot down unless held.

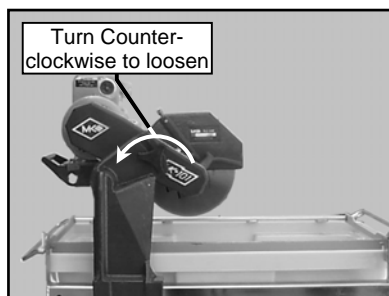

(A)  
Loosen Cutting Head Adjusting Knob



(B)  
Set cutting depth approximately 1/4 to 1/2 inch below the surface of the Movable Cutting Table

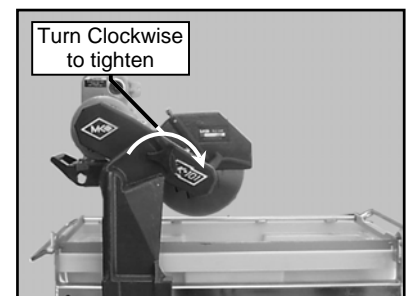

(C)  
Ensure the Adjusting Knob is tight

\* A GFCI wall socket is the preferred protective device.

# SETUP, ADJUSTMENT and OPERATION

## ADJUSTMENT and OPERATION:

### 1. Cutting Straight Edges:

**⚠CAUTION DO NOT FORCE THE TOOL.** It will do the job better and safer at the rate for which it was designed.

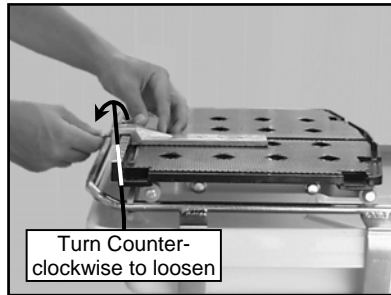

(A)  
Loosen the Adjustable Cutting Guide retaining thumbscrew

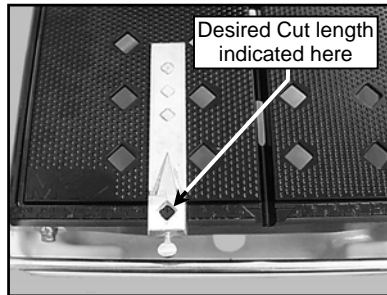

(B)  
Position the Adjustable Cutting Guide to desired cut length indicated inside the diamond

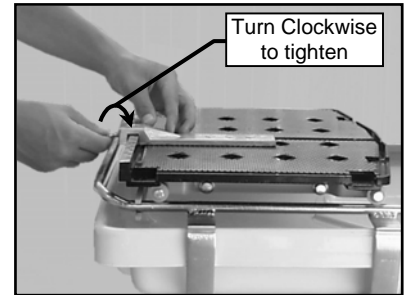

(C)  
Tighten the retaining thumbscrew

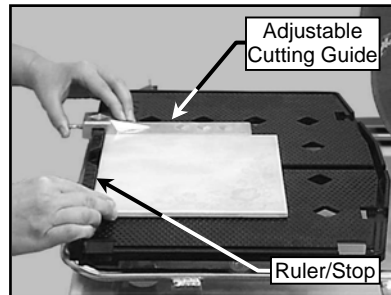

(D)  
Place the tile against the Ruler/Stop and Cutting Guide

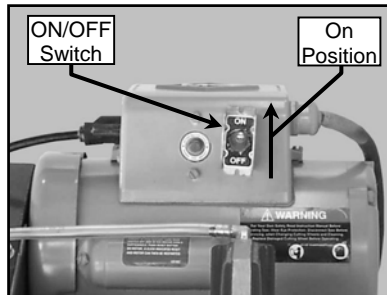

(E)  
Turn the motor ON

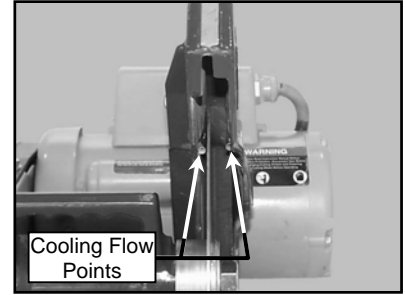

(F)  
Verify proper cooling flow on both sides of the blade (See Maintenance Section to increase/decrease flow)

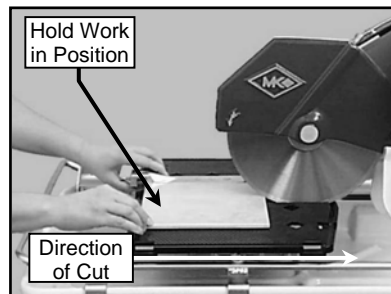

(G)  
Perform the cut

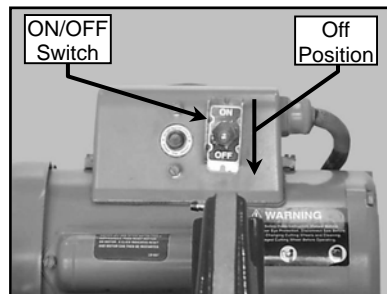

(H)  
Turn the motor OFF when work is complete

# SETUP, ADJUSTMENT and OPERATION

## 2. Diagonal Cutting:

NOTE: To cut diagonal, the Dual 45° Flat Angle Guide (MK Diamond Part No. 134557-MK) should be used.

**⚠CAUTION** DO NOT FORCE THE TOOL. It will do the job better and safer at the rate for which it was designed.

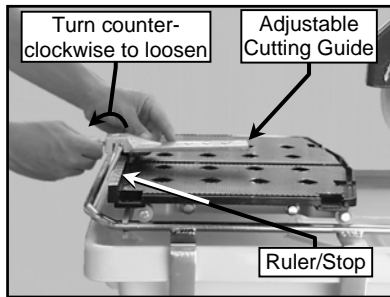

(A)  
Remove the Adjustable Cutting Guide

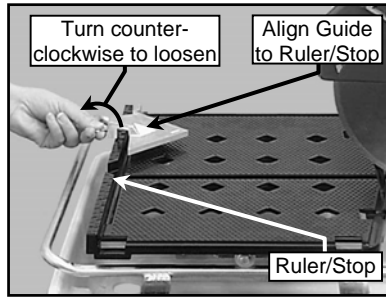

(B)  
Place the Dual 45° Flat Angle Guide on the Ruler/Stop

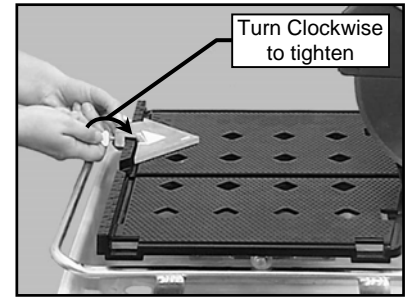

(C)  
Position the Dual 45° Flat Angle Guide and tighten the retaining thumbscrew

NOTE: If Cutting the tile in two equal halves, align the tile in the V-notch of the Movable Cutting Table Ruler/Stop.

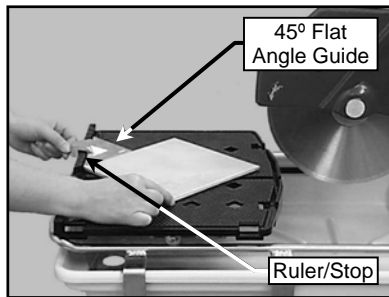

(D)  
Position the tile against the Dual 45° Flat Angle Guide and the Ruler/Stop

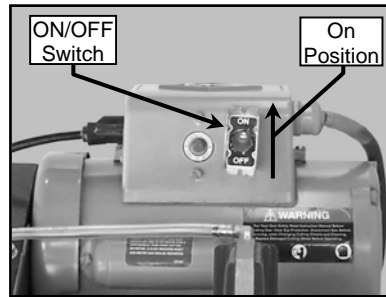

(E)  
Turn the motor ON

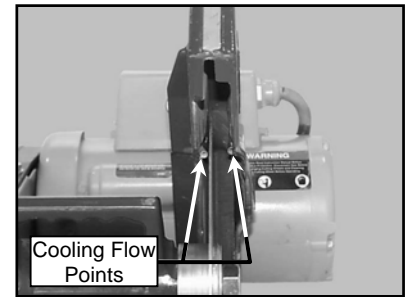

(F)  
Verify proper cooling flow on both sides of the blade (See Maintenance Section to increase/decrease flow)

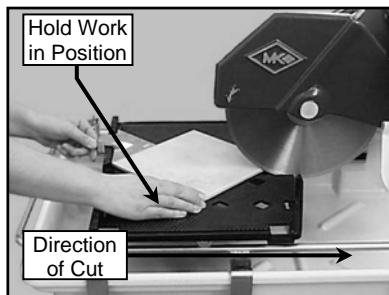

(G)  
Perform the cut

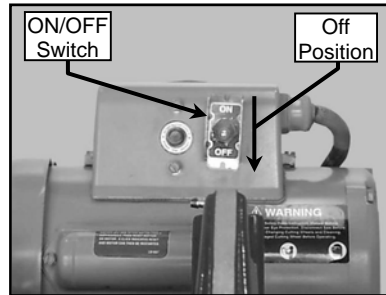

(H)  
Turn the motor OFF when work is complete

# SETUP, ADJUSTMENT and OPERATION

## 3. 45° Miter Cutting:

NOTE: To cut 45° Miters, the 45° Bullnose Miter Guide (MK Diamond Part No. 134585-MK) should be used.

**⚠ CAUTION DO NOT FORCE THE TOOL.** It will do the job better and safer at the rate for which it was designed.

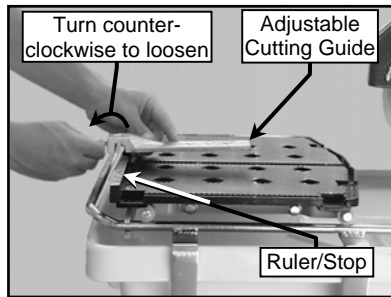

(A)  
Remove the Adjustable Cutting Guide

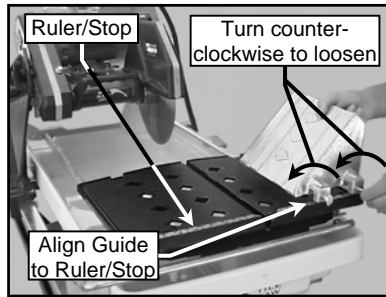

(B)  
Place the 45° Bullnose Miter Guide on the Ruler/Stop

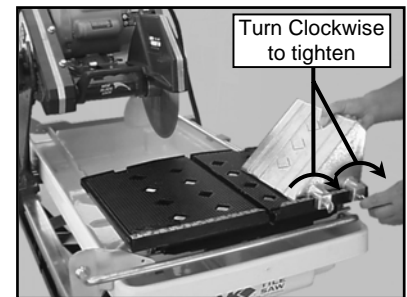

(C)  
Position the 45° Bullnose Miter Guide and tighten the retaining thumbscrew

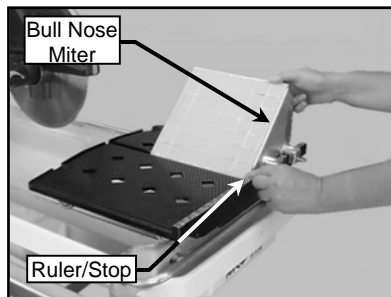

(D)  
Position the tile on the 45° Bullnose Miter Guide and the Ruler/Stop

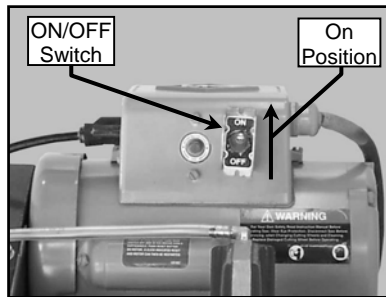

(E)  
Turn the motor ON

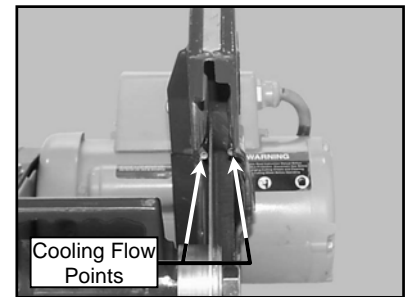

(F)  
Verify proper cooling flow on both sides of the blade (See Maintenance Section to increase/decrease flow)

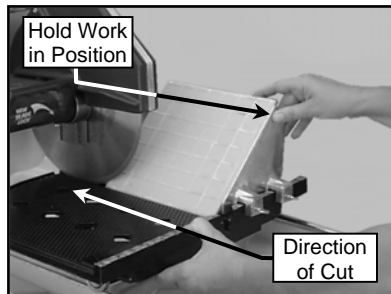

(G)  
Perform the cut

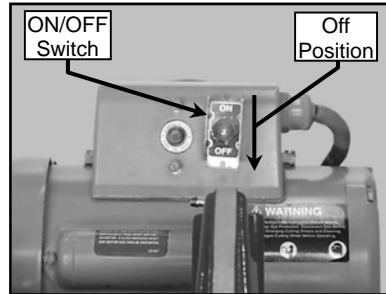

(H)  
Turn the motor OFF when work is complete

# SETUP, ADJUSTMENT and OPERATION

## 4. Off-angle Cutting:

NOTE: To cut angles other than 45° angles or Miters, a 90° Protractor (MK Diamond Part No. 134569-MK) should be used.

**CAUTION** DO NOT FORCE THE TOOL. It will do the job better and safer at the rate for which it was designed.

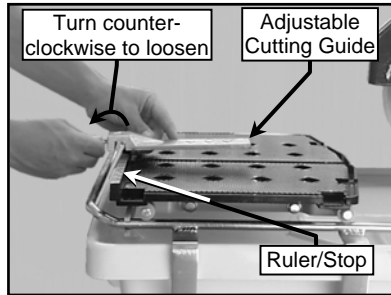

(A)  
Remove the Adjustable Cutting Guide

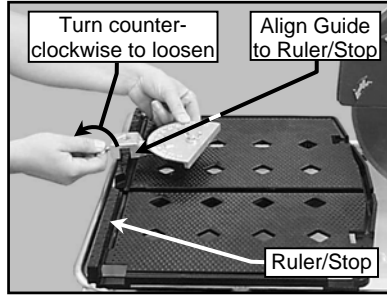

(B)  
Place the 90° Protractor on the Ruler/Stop

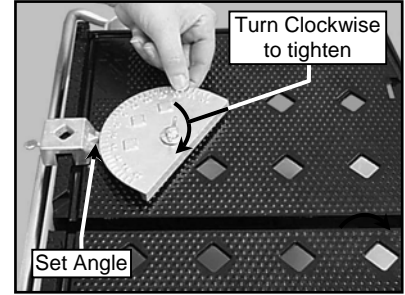

(C)  
Set the desired angle and tighten the thumbscrew

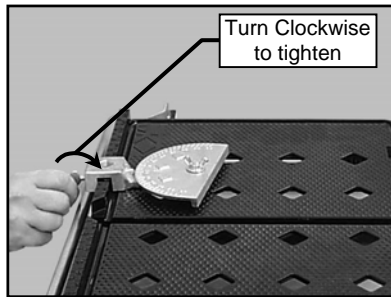

(D)  
Position the 90° Protractor and tighten the retaining thumbscrew

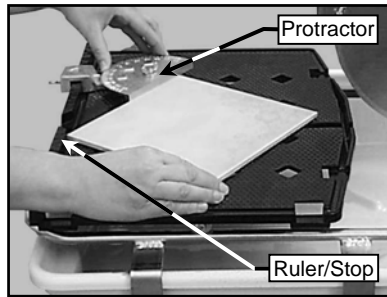

(D)  
Position the tile against the 90° Protractor and the Ruler/Stop

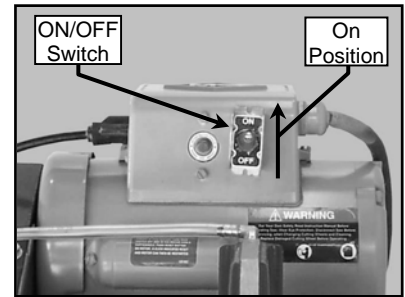

(E)  
Turn the motor ON

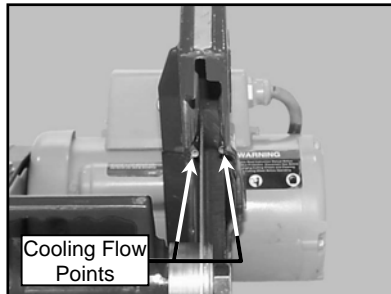

(F)  
Verify proper cooling flow on both sides of the blade (See Maintenance Section to increase/decrease flow)

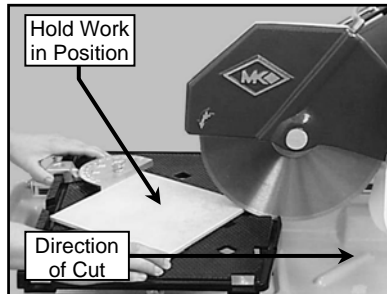

(G)  
Perform the cut

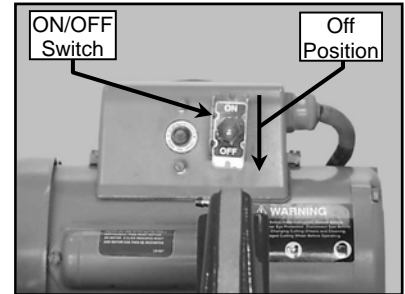

(H)  
Turn the motor OFF when work is complete

## SETUP, ADJUSTMENT and OPERATION

### 5. Adjusting the Cutting Head:

**⚠CAUTION** The Cutting Head is heavy! Care must be used when changing the position of the Cutting Head.

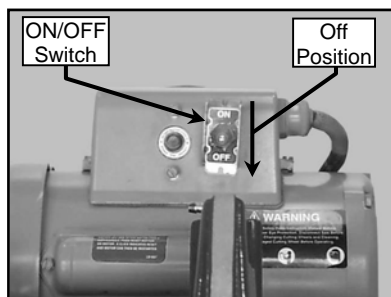

(A)  
Ensure the ON/OFF Switch is in the OFF position

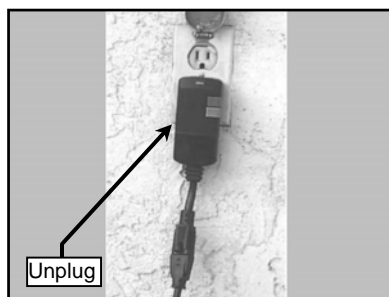

(B)  
Unplug the GFCI from the power source\*

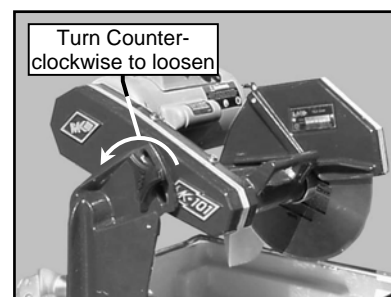

(C)  
Remove Adjusting Knob

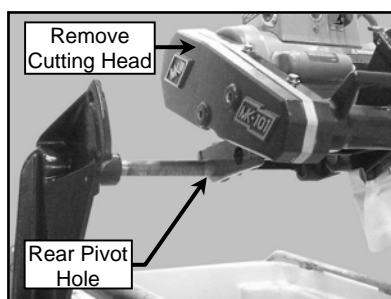

(D)  
Remove the Cutting Head from The rear pivot hole

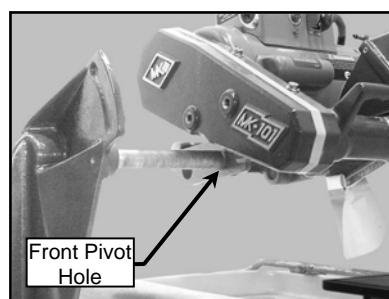

(E)  
Install the Cutting Head onto the front pivot hole

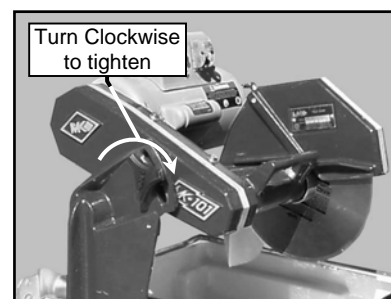

(F)  
Install the Adjusting Knob

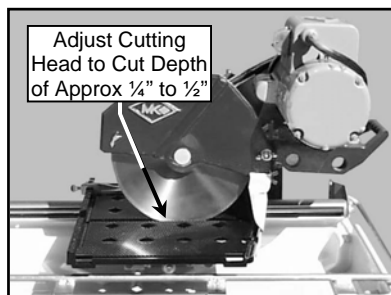

(G)  
Set cutting depth approximately 1/4 to 1/2 inch below the surface of the Movable Cutting Table

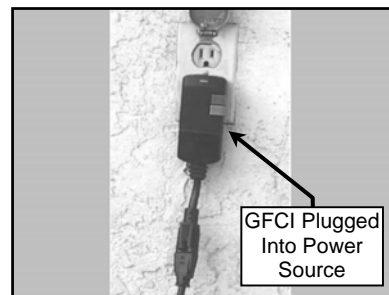

(H)  
Plug the GFCI into the power source\*

\* A GFCI wall socket is the preferred protective device.

# SETUP, ADJUSTMENT and OPERATION

## 6. Adjusting the Post for Maximum Cutting Length:

**⚠CAUTION** The Cutting Head and Post are heavy! Use care when changing the position of the Cutting Head.

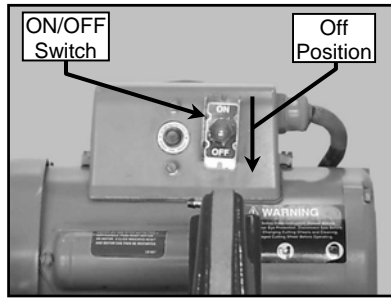

(A)  
Ensure the ON/OFF Switch is in the OFF position

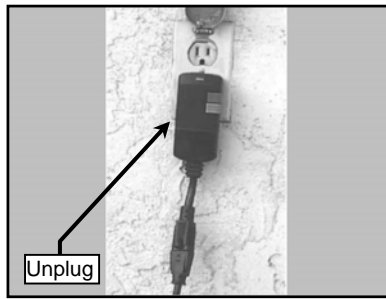

(B)  
Unplug the GFCI from the power source\*

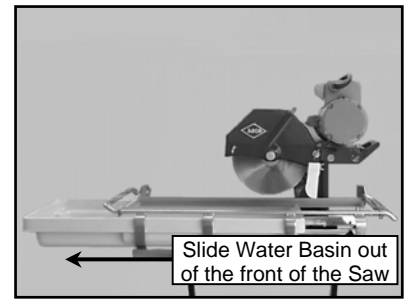

(C)  
Remove Water Basin

**⚠CAUTION** Hold the Post when removing the Post Support Plate.

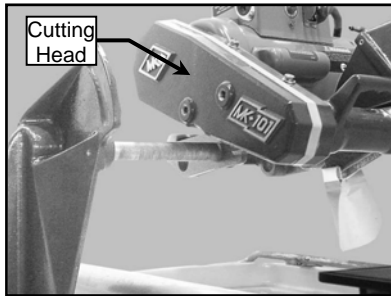

(D)  
Remove the Cutting Head (See Adjusting the Cutting Head)

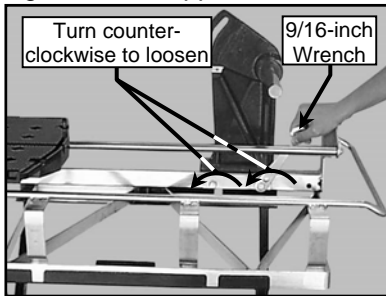

(E)  
Loosen the Post Support Plate and retaining bolts

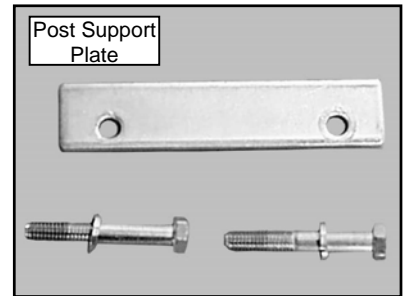

(F)  
Remove the Post Support Plate and retaining bolts

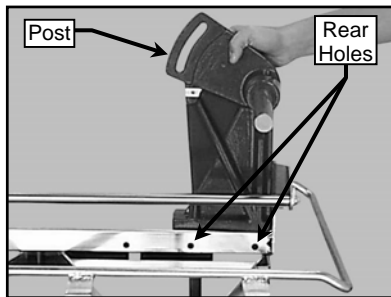

(G)  
Relocate the Post to the rear Post retaining holes

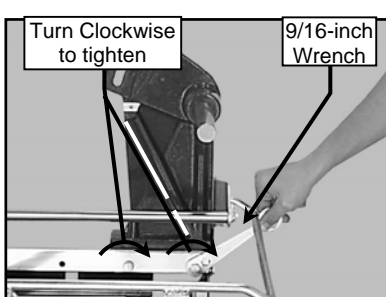

(H)  
Install and tighten the Post Support Plate and retaining bolts

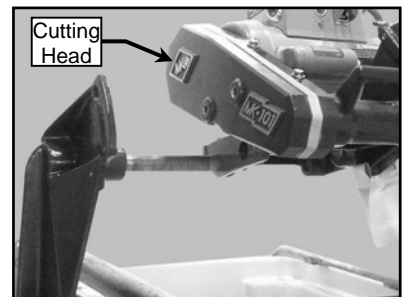

(I)  
Install the Cutting Head (See Adjusting the Cutting Head)

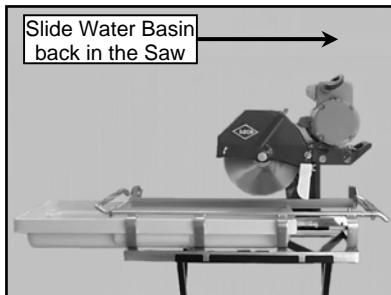

(J)  
Install the Water Basin

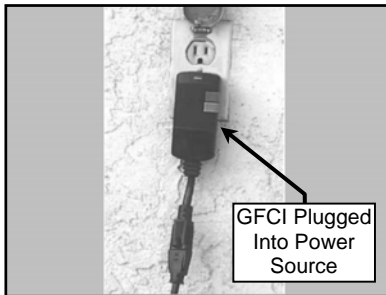

(K)  
Plug the GFCI into the power source\*

\* A GFCI wall socket is the preferred protective device.

# SETUP, ADJUSTMENT and OPERATION

## 7. Cleanup:

- NOTES: 1. If an external water source was used, steps A through C may be skipped.  
2. Dispose of wastewater in accordance with applicable Federal, State and Local laws.

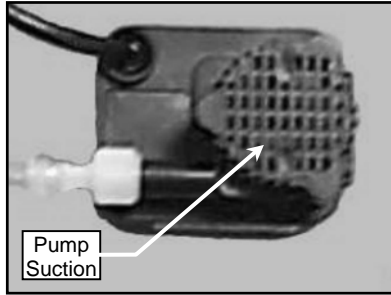

(A)  
Clean the Water Pump suction of all debris

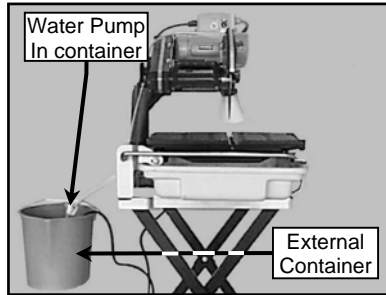

(B)  
Place the Water Pump in an external container

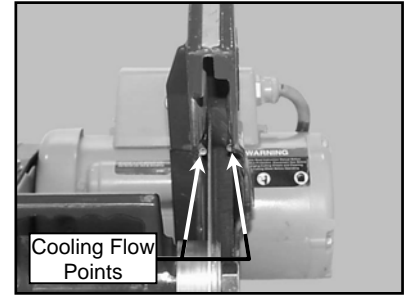

(C)  
Run the MK-101 TRACKER until clear water is seen at the blade

**CAUTION** Ensure the saw is disconnected before completing the remainder of the cleanup process.

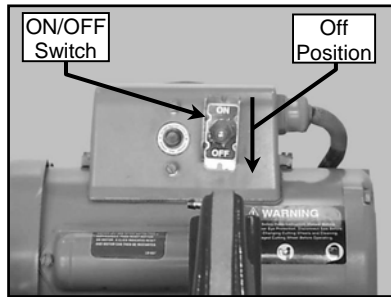

(D)  
Ensure the ON/OFF Switch is in the OFF position

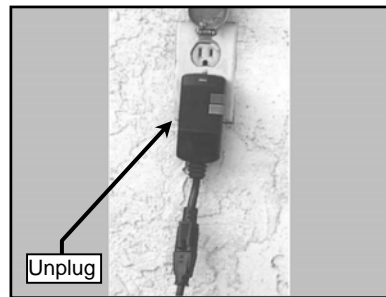

(E)  
Unplug the GFCI from the Power source

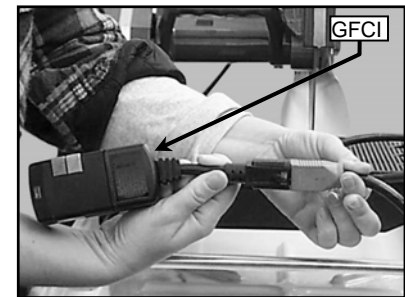

(F)  
Unplug MK-101 TRACKER from the GFCI

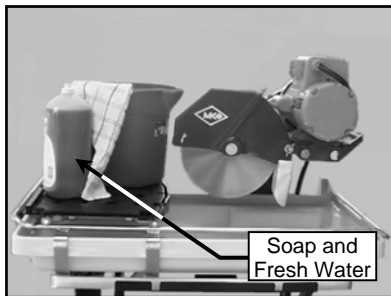

(G)  
Clean the MK-101 TRACKER with soap and clean water

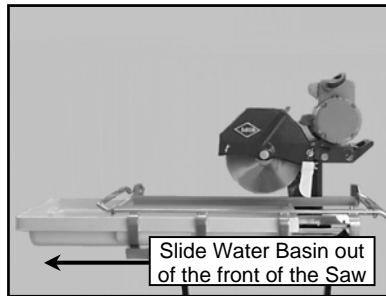

(H)  
Remove the Water Basin from the MK-101 TRACKER

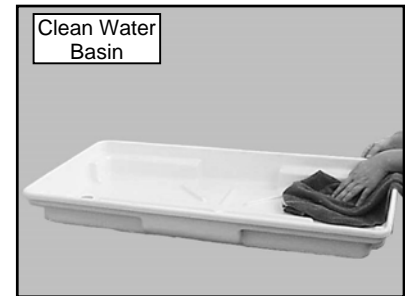

(I)  
Clean the Water Basin

\* A GFCI wall socket is the preferred protective device.



## SETUP, ADJUSTMENT and OPERATION

**⚠CAUTION** Ensure water is not forced into the motor casing when cleaning.

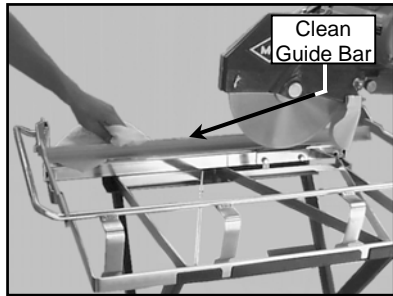

(J)  
Clean the Movable Cutting  
Table Guide Bar

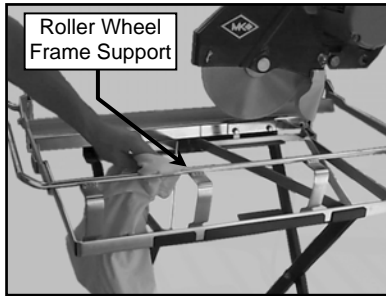

(K)  
Clean the Movable Cutting  
Table Roller Wheel Frame  
Support

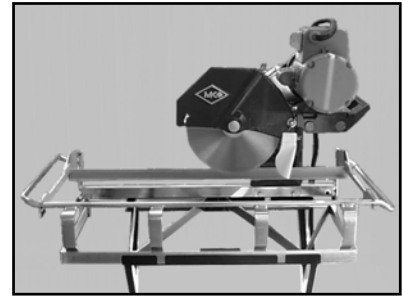

(L)  
Clean the remainder of the  
MK-101 TRACKER

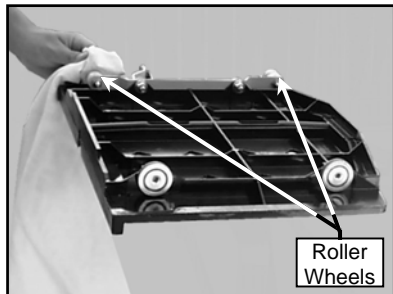

(M)  
Clean the Movable Cutting  
Table Roller Wheels

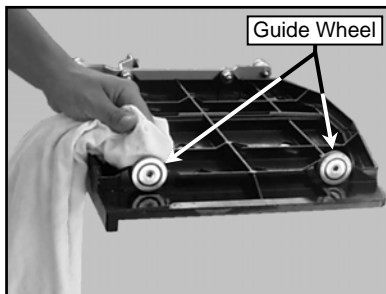

(N)  
Clean the Movable Cutting  
Table Guide Wheels

# MAINTENANCE AND TROUBLESHOOTING

## MAINTENANCE:

### 1. New Maintenance:

Perform the following after initial purchase and operation of the MK-101 TRACKER.

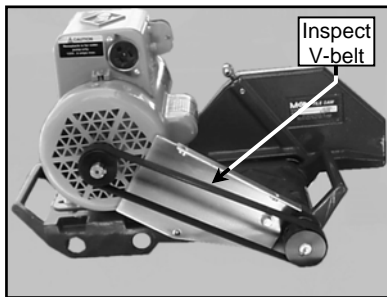

(A)

Check and adjust V-belt tension Following 1<sup>st</sup> 48 hours of operation (See V-belt Inspection)

### 2. Maintenance Following Use:

To extend the life of the MK-101 TRACKER, the following procedure should be performed after each use. Lubricate all points listed below with light oils such as, 3 in 1, WD-40, etc.

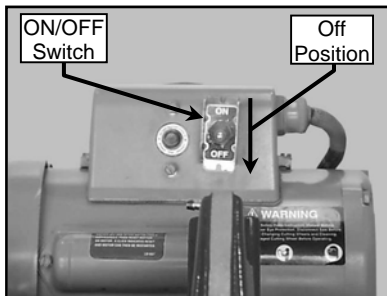

(A)

Ensure the ON/OFF Switch is in the OFF position

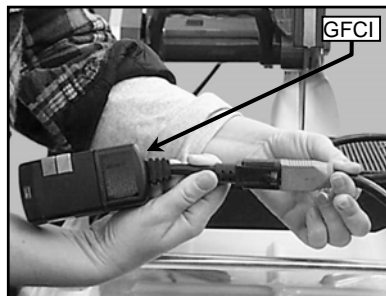

(B)

Unplug MK-101 TRACKER\*

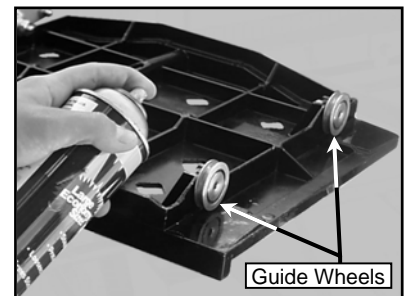

(C)

Lubricate the Guide Wheels

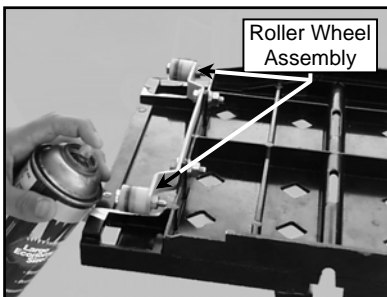

(A)

Lubricate the Roller Wheel Assembly

\* A GFCI wall socket is the preferred protective device.

## MAINTENANCE AND TROUBLESHOOTING

### 3. Monthly Maintenance:

The following maintenance should be performed monthly.

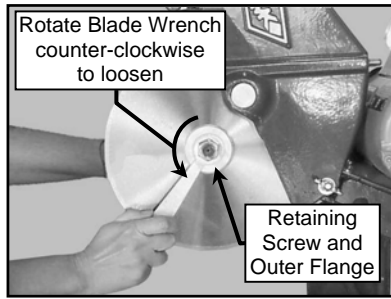

(A)  
Remove the Diamond Blade

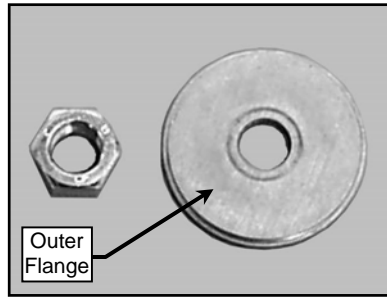

(B)  
Lubricate the Outer Flange and Retaining-nut

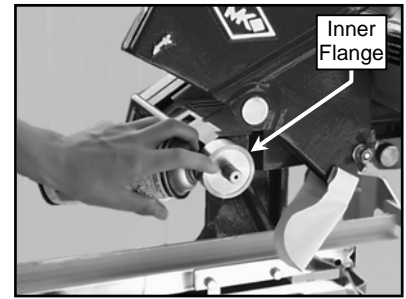

(C)  
Lubricate the Inner Flange

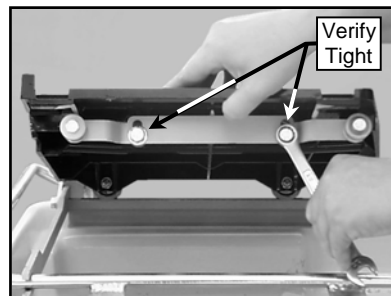

(D)  
Verify the Roller Wheel Assembly is tight and in good condition

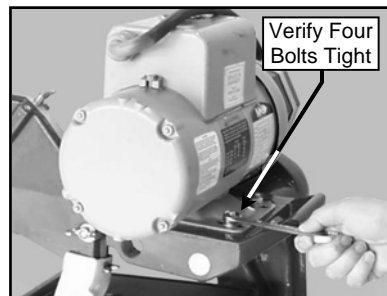

(E)  
Verify all motor mounting Bolts are tight

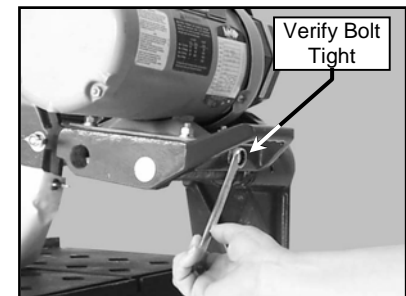

(F)  
Verify the Motor Adjustment Strap is tight

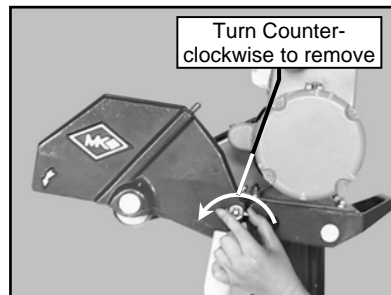

(G)  
Remove the Blade Guard

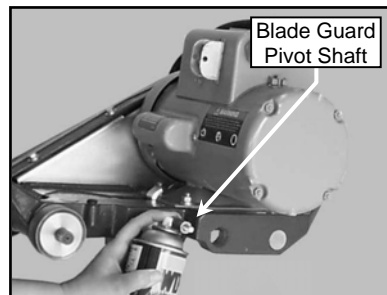

(H)  
Lubricate the Blade Guard Pivot Shaft

## MAINTENANCE AND TROUBLESHOOTING

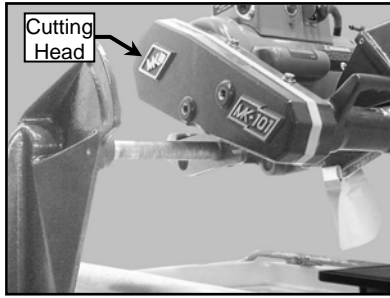

(I)  
Remove the Cutting Head (See  
Adjusting the Cutting Head)

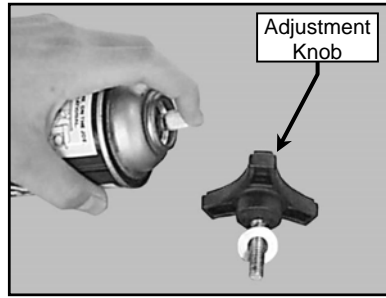

(J)  
Lubricate the Cutting Head  
Adjustment Knob

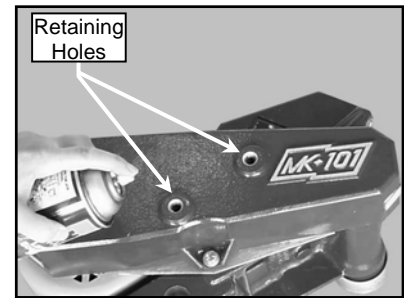

(K)  
Lubricate the Cutting Head  
Adjustment Knob retaining holes

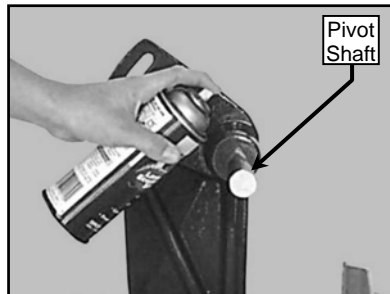

(L)  
Lubricate the Cutting Head  
Pivot Shaft

### 4. Flow Adjustment:

NOTE: If flow to the diamond blade requires adjustment, perform the following actions.

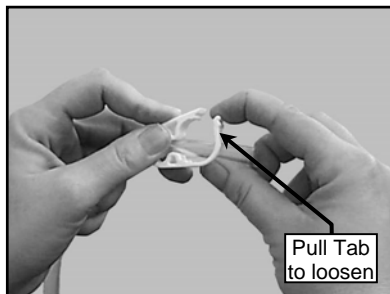

(D)  
Increase cooling flow by  
releasing the Flow Adjusting  
Clamp

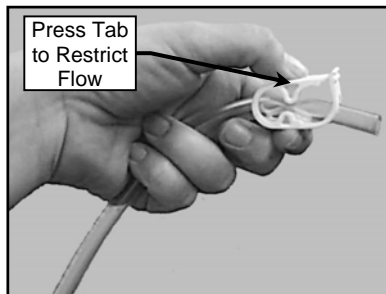

(E)  
Reduce cooling flow by  
Pressing down on the Flow  
Adjusting Clamp

# MAINTENANCE AND TROUBLESHOOTING

## 1. Blade Dressing:

Like most cutting instruments, a diamond blade performs best when it is dressed. Over time and use, diamonds on the outer edge of the blade will become smoothed or “glazed” over. This will reduce grinding efficiency and may cause the blade to “wander” or bend giving the illusion of an alignment problem. When this occurs, the blade will need to be dressed. The diamond blade can be dressed using the MK Dressing Stick (part number 152972) and by following the steps below.

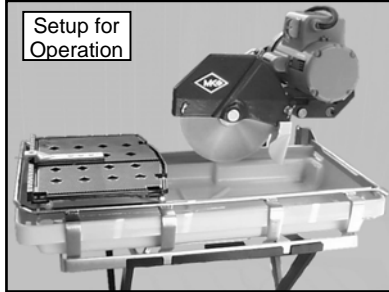

(A)  
Setup the MK101 for operation  
(See Setup, Adjustment  
and Operation)

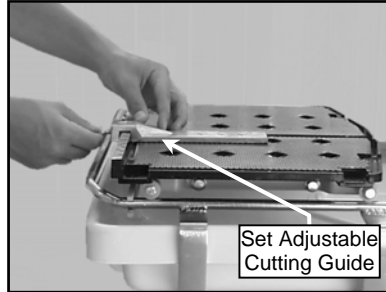

(B)  
Set the Adjustable Cutting Guide  
to cut a 1/16-strip

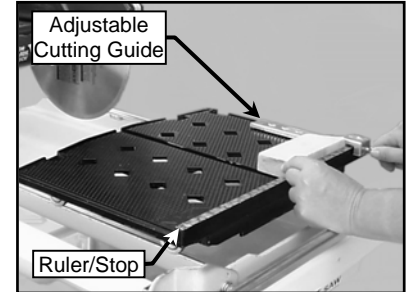

(C)  
Position the Dressing Stick

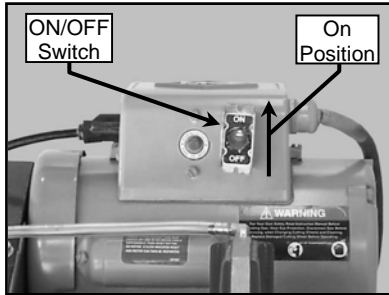

(D)  
Turn the motor ON

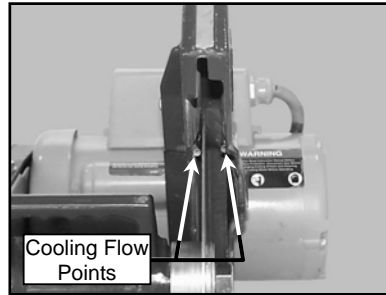

(E)  
Verify proper cooling flow on  
both sides of the blade (See  
Maintenance Section to  
increase/decrease flow)

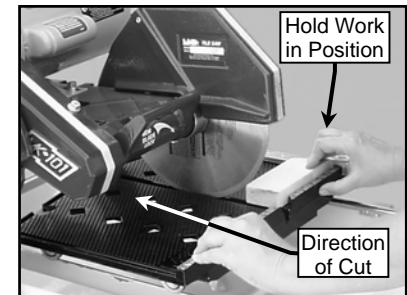

(F)  
Cut the Dressing Stick 7 or 8  
times to dress the Blade

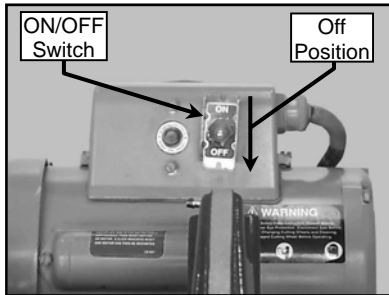

(G)  
Ensure the ON/OFF Switch  
is in the OFF position

## MAINTENANCE AND TROUBLESHOOTING

### 2. Diamond Blade Change-out:

NOTE: When installing the Retaining Screw, do not "cross-thread" and DO NOT over tighten the screw.

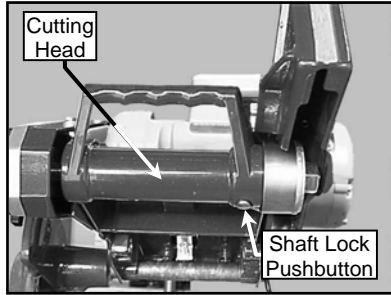

(A)  
Locate the Shaft Lock pushbutton on the underside of the Cutting Head

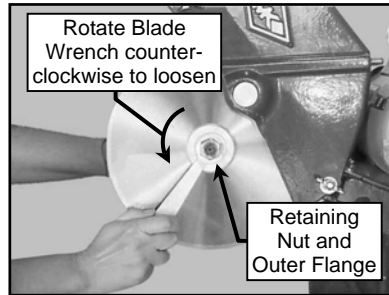

(B)  
Remove Retaining Nut and Outer Flange, depress and hold the Shaft Lock pushbutton and loosen

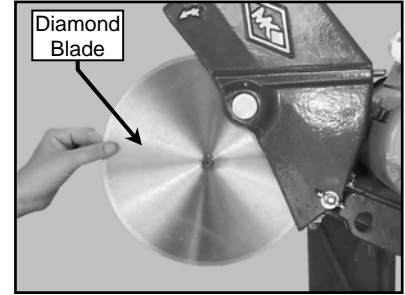

(C)  
Remove the Diamond Blade

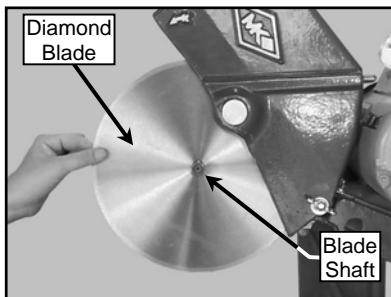

(D)  
Install the Diamond Blade onto Blade Shaft

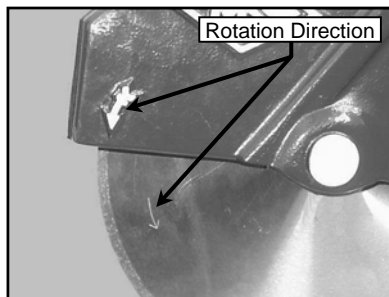

(E)  
Verify the Blade is seated on the Blade Shaft and direction of rotation is correct

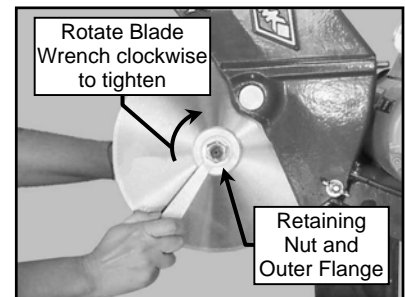

(F)  
Install Retaining Nut and Outer Flange, depress and hold the Shaft Lock pushbutton and tighten

### 3. Cutting Head Stop Installation:

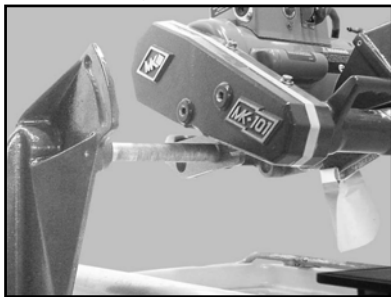

(A)  
Remove the Cutting Head (See Adjusting the Cutting Head)

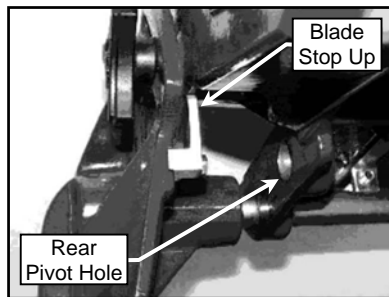

(B)  
Install Head Stop UP, when the Cutting Head is installed on the rear Pivot Hole

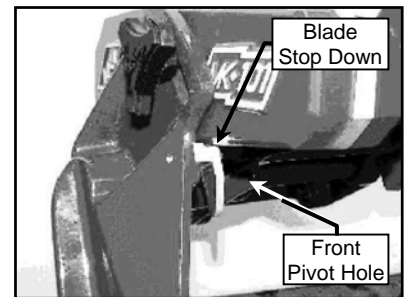

(C)  
Install Head Stop DOWN, when the Cutting Head is installed on the forward Pivot Hole

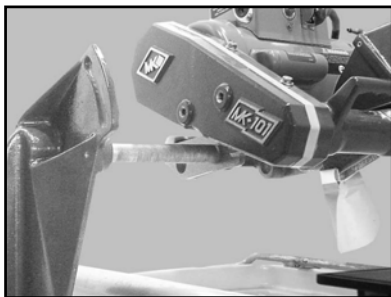

(D)  
Reinstall the Cutting Head (See Adjusting the Cutting Head)

## MAINTENANCE AND TROUBLESHOOTING

### 4. V-Belt Inspection, Adjustment and Replacement:

The MK-101 TRACKER is designed with a power transmission V-belt. In order to ensure the MK-101 TRACKER operates at peak efficiency, the V-belt should be inspected monthly, and changed if the V-belt shows damage and/or excessive wear.

NOTE: 1. When a new belt is installed, it should be inspected and re-tensioned after the first forty-eight (48) hours of operation.

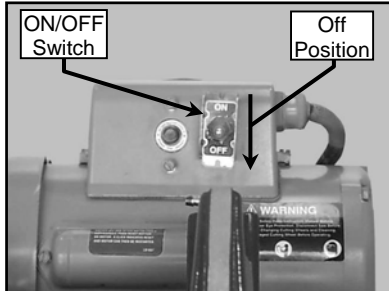

(A)  
Ensure the ON/OFF Switch is in the OFF position

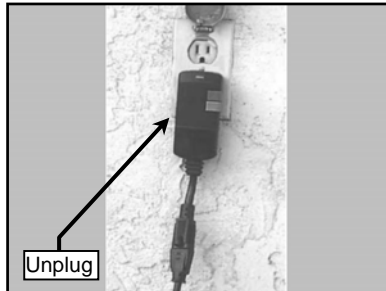

(B)  
Unplug the GFCI from the Power source\*

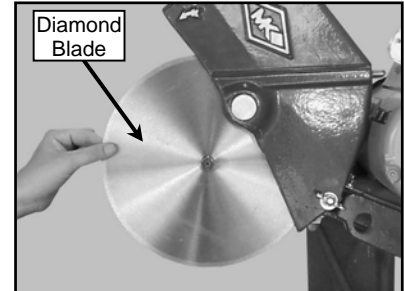

(C)  
Remove the Diamond Blade

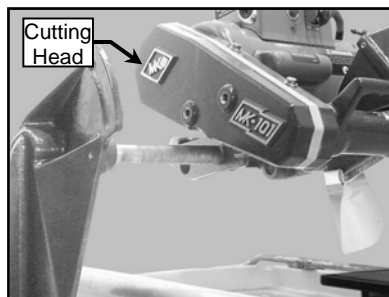

(D)  
Remove the Cutting Head (See Adjusting the Cutting Head)

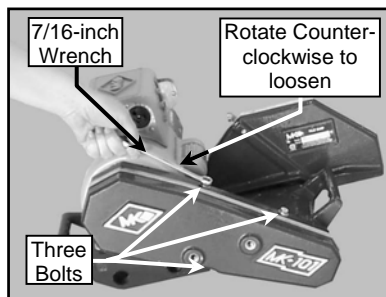

(E)  
Remove the Belt Guard

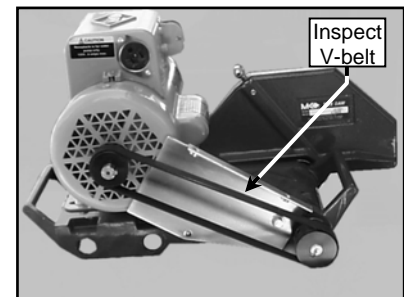

(F)  
Inspect the V-belt for cracks, Fraying, separation and wear. Go to step H if replacement required

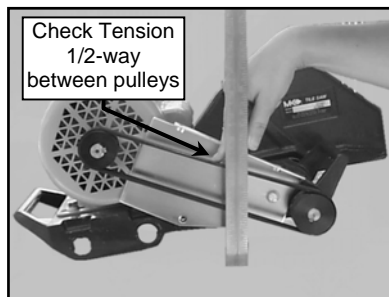

(G)  
Check the belt for proper tension if tension is correct, go to step R (proper tension 1/8-inch)

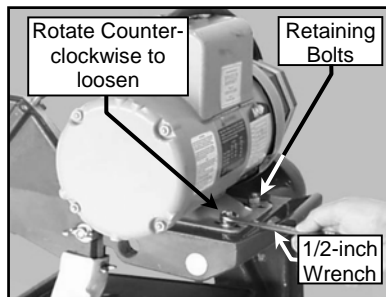

(H)  
Loosen the motor mounting bolts, if re-tensioning only, go to step N

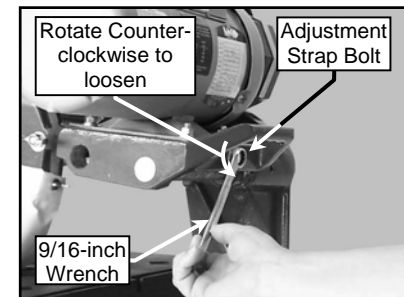

(I)  
Loosen the Motor Adjustment Strap

\* A GFCI wall socket is the preferred protective device.

## MAINTENANCE AND TROUBLESHOOTING

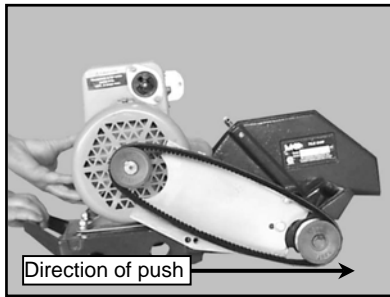

(J)  
Push the motor toward the front of the Cutting Head to loosen the V-belt

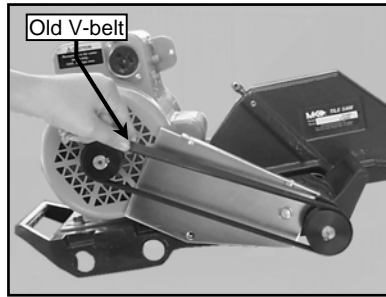

(K)  
Remove the V-belt

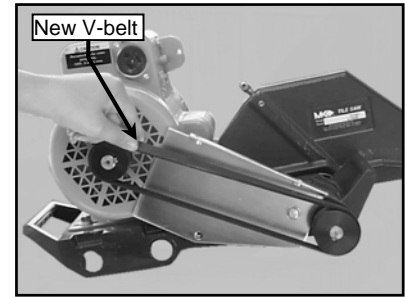

(L)  
Install the new V-belt

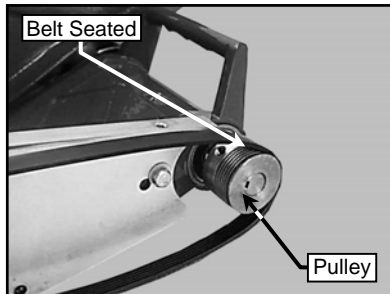

(M)  
Verify the V-belt is seated in the grooves of both pulleys

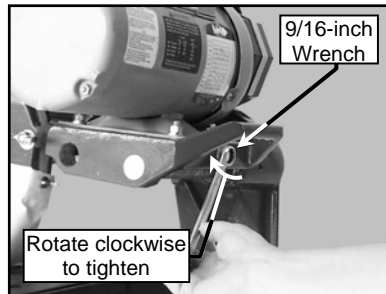

(N)  
Tighten the Motor Adjustment Strap to remove slack

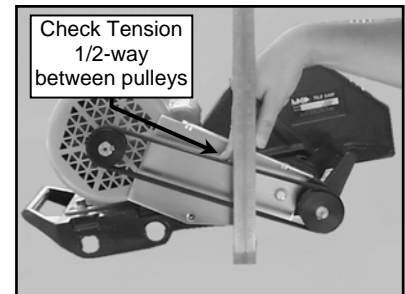

(O)  
Check V-belt tension (proper tension 1/8-inch)

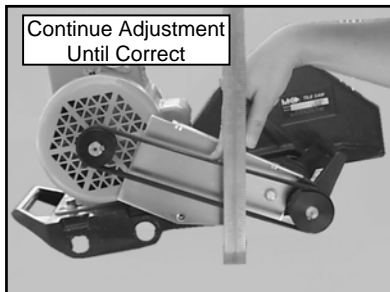

(P)  
Repeat steps N and O until proper V-belt tension is achieved

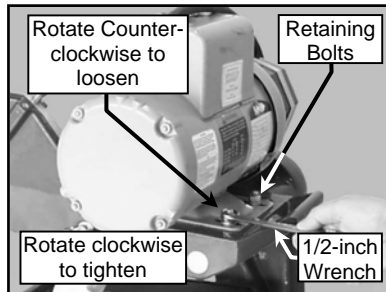

(Q)  
Tighten the motor mounting bolts

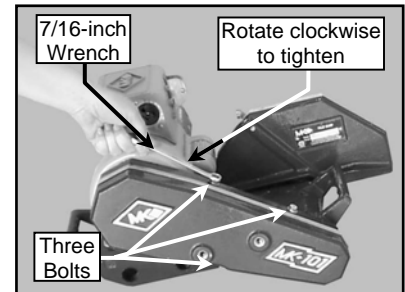

(R)  
Install the Belt Guard



# MAINTENANCE AND TROUBLESHOOTING

## 5. Cutting Table Alignment:

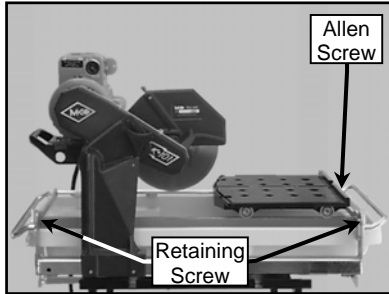

(A)  
Locate the Frame Retaining  
Screws and Allen screw

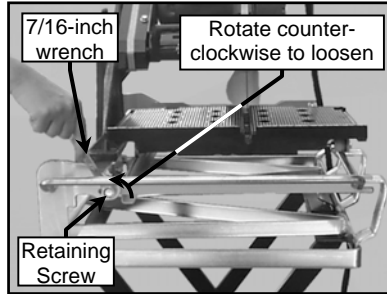

(B)  
Loosen the front Frame  
Retaining Screw

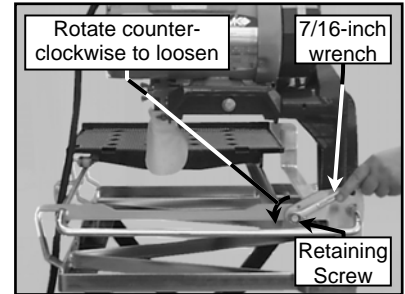

(C)  
Loosen the back Frame Retaining  
Screw

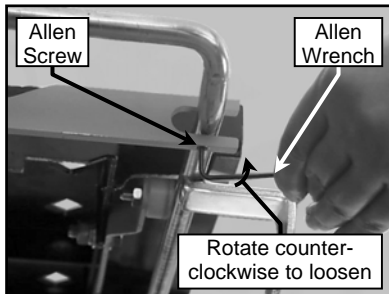

(D)  
Loosen the front Frame Allen  
Screw

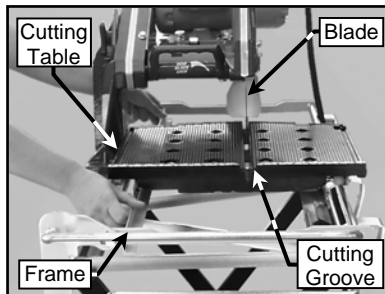

(E)  
Adjust the Frame until the  
Movable Cutting Table, Cutting  
Groove is centered with the  
Blade

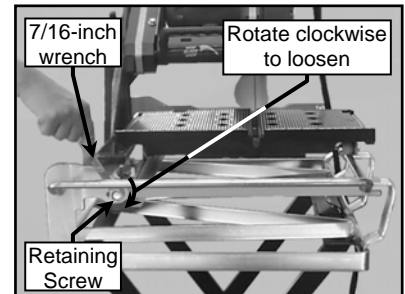

(F)  
Tighten the front Frame Retaining  
Screws

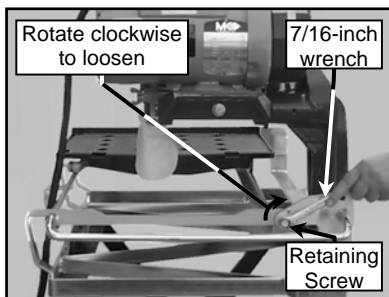

(G)  
Tighten the back Frame  
Retaining Screws

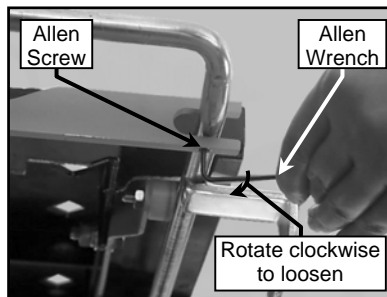

(H)  
Tighten the front and back  
Frame Allen Screws

# MAINTENANCE AND TROUBLESHOOTING

## TROUBLESHOOTING:

### 1. Blade will not cut properly:

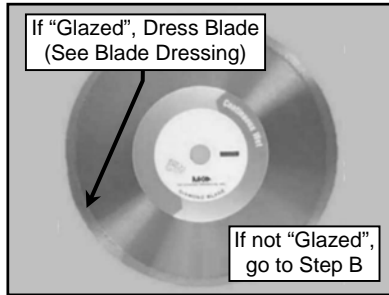

(A)  
Check for Smoothness  
or "Glazing" (Dress blade  
if needed)

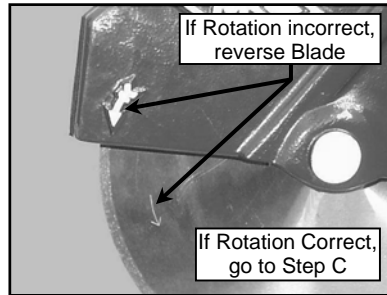

(B)  
Check for proper blade rotation

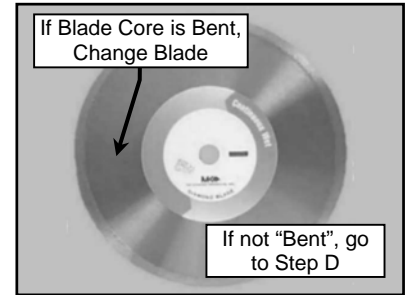

(C)  
Ensure the Blade Core  
is not bent



(D)  
Verify the blade is correct for  
the material being used

**Return to  
MK Diamond  
for Repair**

(E)  
Return to MK Diamond

### 2. Movable Cutting Table Does Not Move Correctly:

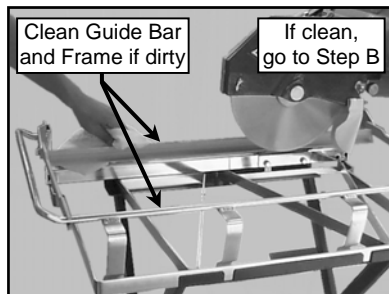

(A)  
Check the Guide Bar and  
Frame for cleanliness –  
clean if dirty

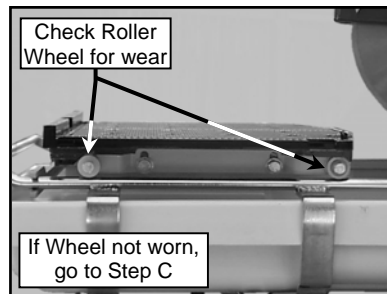

(B)  
Check the Movable Cutting Table  
Roller Wheels for wear –  
replace if necessary

**Return to  
MK Diamond  
for Repair**

(C)  
Return to MK Diamond

# MAINTENANCE AND TROUBLESHOOTING

## 3. Cooling Flow:

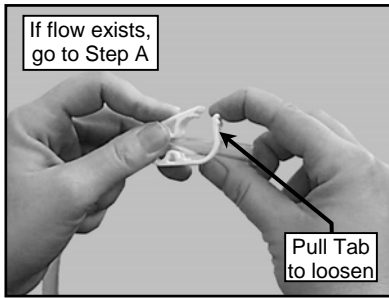

(A)  
Verify the cooling flow  
Adjusting Clamp is open

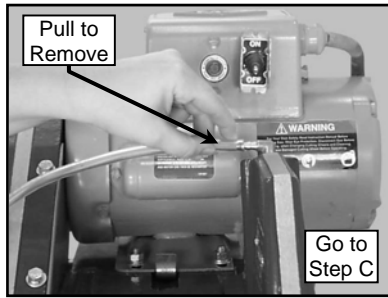

(B)  
Remove the Cooling Transfer  
Tube from the Blade Guard inlet

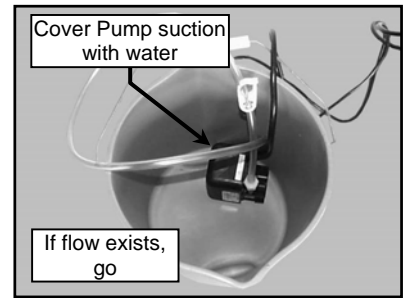

(C)  
Place Pump into a bucket of  
water and check flow

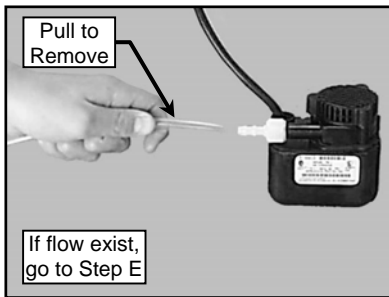

(D)  
Remove the Cooling Transfer  
Tube and check for flow

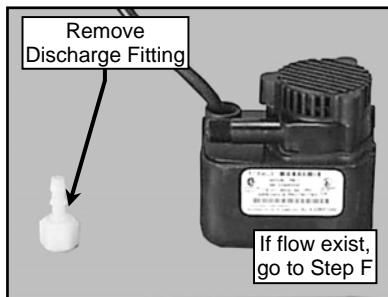

(E)  
Remove the Pump Discharge  
Fitting and check for flow

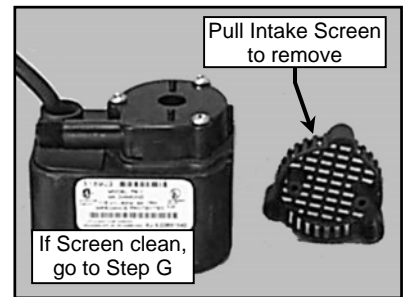

(F)  
Remove the Pump Intake  
Screen and check for debris –  
clean the screen if necessary

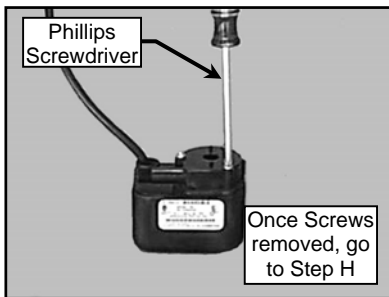

(G)  
Remove the 3 Pump Casing  
Retaining Screws

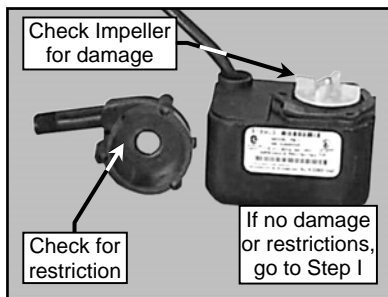

(H)  
Remove the Pump Casing and  
check for restriction in the casing.  
Check the Impeller damage

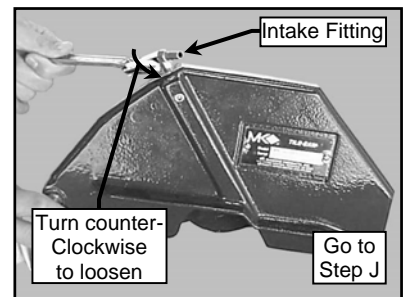

(I)  
Remove the Blade Guard  
Intake Fitting

# MAINTENANCE AND TROUBLESHOOTING

NOTE: "Rodding" cooling channels is performed by inserting a small wire rod through the cooling inlet on top of the Blade Guard and directing the rod out through each of the cooling flow tubes located on the underside of the Blade Guard. The cooling channels should be "rodded" until all ports are free of foreign debris.

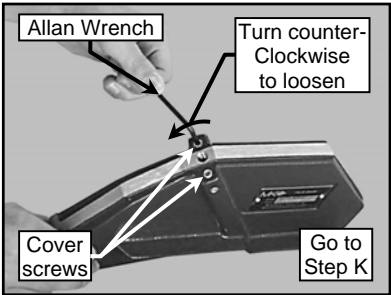

(J)  
Remove the Cooling Channel cover screws

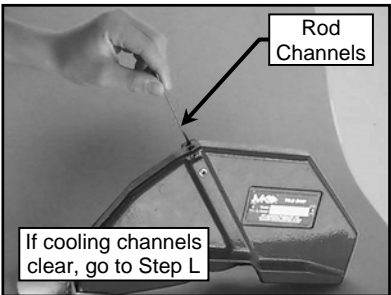

(K)  
Rod the Cooling Channels and then recheck flow

**Return to MK Diamond for Repair**

(L)  
Return to MK Diamond

# MAINTENANCE AND TROUBLESHOOTING

## 4. Blade Stops Turning:

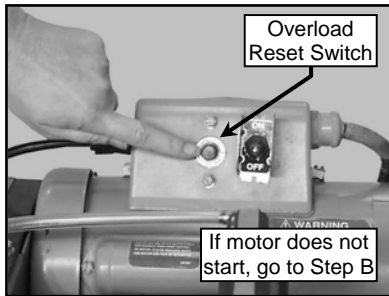

(A)

Allow the motor to cool and depress motor Overload Reset Switch

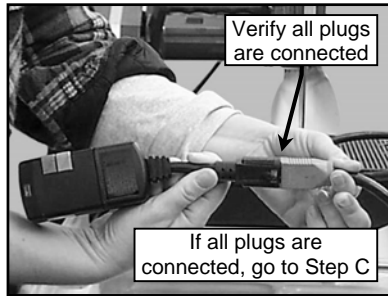

(B)

Verify all plugs are fully installed\*

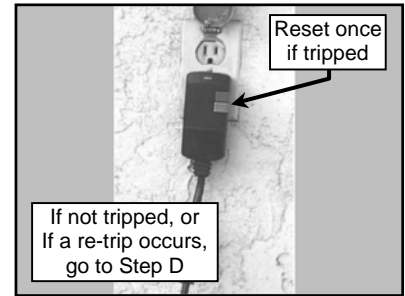

(C)

Check to see if the Ground Fault Circuit Interrupter (GFCI) is tripped\*

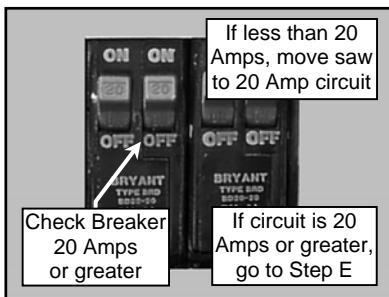

(D)

Verify the circuit breaker is at least 20 amps – if not, move to a 20-amp circuit

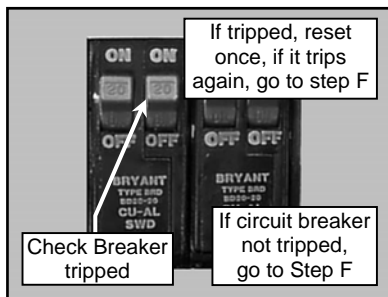

(E)

Verify circuit breaker is not tripped, if it is tripped – reset the circuit breaker once

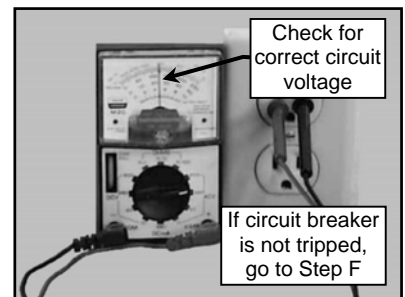

(F)

Check power source voltage is 115V, if it is not 115v – move to another circuit

**Return to  
MK Diamond  
for Repair**

(G)

Return to MK Diamond

\* A GFCI wall socket is the preferred protective device.

# EXPLODED VIEW AND PARTS LIST

## EXPLODED VIEW:

CUTTING HEAD ASSEMBLY (F-J), P/N 158478

MK-101 TRACKER SAW, EXPLODED VIEW

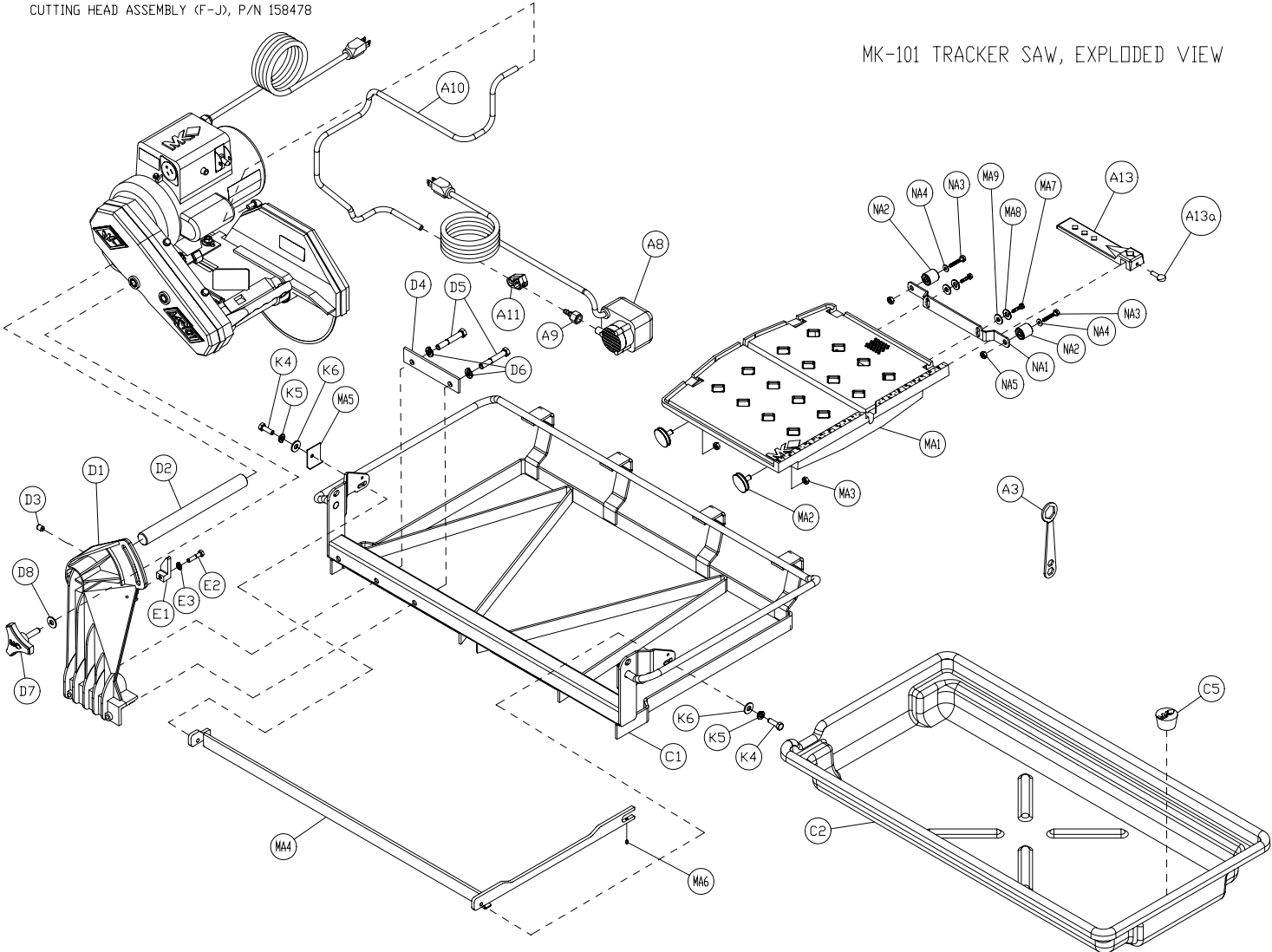

## EXPLODED VIEW AND PARTS LIST

### PARTS LIST:

Item	Description	Qty	Part #	*Rev
<b>A</b>	<b>Accessories</b>	-	-	-
A1	Carton, Accessory Pack, 101	1	153366	*
A2	Foam, Accessory Pack Carton	1	154022	*
A3	Wrench, 15/16 Closed End	1	134684	*
A4	Curtain, Splash	1	134841	*
A5	Bracket, Splash Curtain	1	152571	
A6	Wing screw, 1/4-20 X 1/2	1	151888	
A7	Washer, 1/4 SAE Flat	1	151915	
A8	Pump, Water, G-150A	1	151271	*
A9	Fitting, Plastic, 1/4 FNPT X 1/4 BARB	1	128397	
A10	Hose, Vinyl, 1/4 ID	2'	132951	
A11	Clamp, Flow, 1/4-1/2	1	154394	
A12	Owner's Manual, Water Pump, G-150A	1	155745	
A13	Rip Guide	1	134551	*
	a) Screw, 1/4-20 X 3/4 Thumb	1	150991	
A14	Large Bullnose Accessory	1	153201	*
	Screw, 1/4-20 X 3/4 Thumb	2	150991	
A20A	Owner's Manual, MK-101 Tracker Saw	1	159701	*
A21	Card, MK Warranty Registration	1	155037	*
A22	Label, Do Not Return	1	157063	*
A24	Stand, Folding, Universal	1	151889	*
A25	Blade, MK-100, 10 X 060 X 5/8	1	154380	*
A26B	Label, Tile saw Serial #, UL Mark	1	157249-02	*
<b>C</b>	<b>Frames</b>	-	-	-
C1	Frame, 101	1	153003	*
C2	Pan, Plastic, 101	1	150634	*
C3	Pin, 3/16 X 3/8 Roll	2	151783	*
C4	Plate, Adjustment	2	151758	*
C5	Plug, Rubber Drain	1	153439	*
C6	Tag, Saw Hang MK-101	1	155839	*
<b>D</b>	<b>Posts</b>	-	-	-
D1	Post, 101, MK Red	1	155670	*
D2	Shaft, 10.63" Pivot, 101	1	153254	*
D3	Screw, 3/8-16 X 1/2 Socket Head Set	1	153710	*
D4	Plate, Support	1	155671	*
D5	Screw, 3/8-16 X 2 1/2 Hex Head Cap	2	156030	*
D6	Washer, 3/8 Split Lock	2	150925	*
D7	Knob, 3/8-16 X 1.5 MK Adjustment	1	156770-02	*
D8	Washer, 3/8 SAE Flat	1	150923	*
-	<b>Kit, Stop, 10" Cutting Head</b>	1	157728-MK	-0-
E1	Stop, 10" Cutting Head	1	157728	*
E2	Screw, 1/4-20 X 1 1/4 Hex Head Cap	1	157145	*
E3	Washer, 1/4 Split Lock	1	152591	*

## EXPLODED VIEW AND PARTS LIST

<b>F-J</b>	<b>Cutting Head Assemblies</b>		-	-	-
-	<b>Assembly, DC Cutting Head, MK-101</b> 1-1/2hp\120V60Hz\1PH		1	158478	-0-
<b>F</b>	<b>Belt Guards</b>				
F1	Belt Guard, MK-101		1	158319-01	*
F2	Bracket, Inner Belt Guard, 100/101		1	158611	*
F3	Screw, 1/4-20 x 3/4 Hex Head Cap		3	152370	*
F4	Screw, 1/4-20 x 1 Hex Head Cap		1	152676	*
F5	Washer, 1/4 Split Lock		4	152591	*
F6	Washer, 1/4 SAE Flat		4	151915	*
F7	Belt, 260J6 Micro-V		1	158194	*
<b>G</b>	<b>Blade Guard Assemblies</b>		-	-	-
-	<b>Assembly, Blade Guard, MK-101/115</b>		1	152582	-0-
		G1-4			
G1	Blade Guard, 101/115		1	153659	*
G2	Tube, Water		2	155389	*
G3	Screw, 5/16-18 X 1/2 Socket Head Set		3	152607	*
G4	Elbow, 1/8 MNPT X 1/4 BARB 90° Brass		1	154652	*
<b>H</b>	<b>Motors</b>		-	-	-
H1	Motor, 1-1/2HP\120V\60Hz		1	151473	*
H2	Pulley, 6J17 X 5/8 Bore		1	158214	*
H3	Key, 3/16 x 3/16 x 1-1/8 Square		1	150344	*
H4	Screw, 5/16-18 X 3/8 Socket Head Set, Cup Point		2	157083	*
H5	Label, Warning most motor..., 2 3/4 X 2 7/16		1	155672	*
H6	Label, Caution, GFCI, 1 X 2 1/8		1	155678	*
H7	Label, Caution, 5 Amp Max., 1 X 2-1/8		1	154822	*
H8	Label, Warning, Read Owner's Manual, 1-3/4 X 3-3/8		1	155806	*
H9	Label, MK Service Info., 2 1/8 X 1-13/16		1	155038	*
<b>J</b>	<b>Cutting Head Subassemblies</b>		-	-	-
-	<b>Subassembly, DC Cutting Head, 100/101</b>		1	158191	-0-
J1	Cutting Head, DC, 100/101, MK Red		1	158224	*
J2	Pin, Blade Shaft Lock		1	158200	*
J3	Spring, Blade Guard Lock		1	158201	*
J4	E-Ring, 1/4 Retaining		1	158202	*
J5	Bearing, 17mm X 40mm X 12mm Ball (6203-2NSE)		2	137711	*
J6	Shaft, Blade 100/101		1	158222	*
J7	Flange, 2-3/8 Inner		1	137737	*
J8	Flange, 2-3/8 Outer		1	135830	*
J9	Nut, 5/8-18 Hex		1	135848	*
J10	Pulley, 6J19 X 5/8 Bore		1	158199	*
J11	Key, 3/16 x 3/16 x 1 1/8 Square		1	150344	*
J12	Screw, 5/16-18 X 3/8 Socket Head Set, Cup Point		2	157083	*
J13	Bumper, 1/2 Dia Rubber		1	152674	*
J14	Screw, 5/16-18 X 1 Hex Head Cap		4	151743	*
J15	Washer, 5/16 SAE Flat		4	151754	*
J16	Washer, 5/16 Split Lock		4	151747	*
J17	Nut, 5/16-18 Hex		4	101196	*
J18	Screw, 5/16-18 x 2 1/2 Hex Head Cap, Full Thread		1	151748	*
J18A	Bolt, 5/16-18 x 2 1/2 Carriage		1	152675	*
J19	Pivot, Blade Guard		1	153208	*
J20	Washer, 3/8 SAE Flat		2	150923	*
J21	Wingnut, 5/16-18 Nylock		1	151746	*



## EXPLODED VIEW AND PARTS LIST

J22	Strap, Motor Adjustment	1	152673	*
J23	Screw, 3/8-16 X 3 1/2 Hex Head Full Thread	1	153147	*
<b>K-N</b>	<b>Table Assemblies</b>	-	-	-
-	<b>Assembly, Tracker Wheel Table, MK 101</b>	<b>1</b>	<b>159554</b>	<b>-0-</b>
<b>MA</b>	Table, Tracker Wheel	-	-	-
-	Assembly, Tracker Wheel Table	1	159554	*
MA1	Table, 101 Tracker Wheel	1	158962	*
MA2	Wheel, Conveyor Cart	2	133090	*
MA3	Nut, Hex w/ WSHR 5/16-18	2	153942	*
MA4	Frame, 101 Tracker Wheel	1	158937	*
MA5	Stop, MK 101 Tracker Wheel Table	1	159652	*
MA6	Screw, 10/24 x 1/4 Socket Set – Cup PT	2	157522	*
MA7	Screw, 5/16-18 x 3/4 Hex Head Cap	2	151369	*
MA8	Washer, 5/16 Split Lock	2	151747	*
MA9	Washer, 5/16 SAE Flat	2	151754	*
<b>NA</b>	Dual Roller Wheel	-	-	-
-	<b>Assembly, Dual Roller Wheel</b>	<b>1</b>	<b>159549</b>	<b>-0-</b>
NA1	Bracket, Dual Roller Wheel	1	159548	*
NA2	Wheel, Roller	2	151799	*
NA3	Screw, 1/4-20 X 1 1/2 Hex Head Cap	2	151914	*
NA4	Washer, 1/4 SAE Flat	2	151915	*
NA5	Nut, 1/4-20 Hex	2	151893	*
NA6	Shim, .004 X 5/16 ID X 1/2 OD	~4	152519	*

## THEORY

### THEORY OF DIAMOND BLADES:

Diamond blades do not really cut; they grind the material through friction. Diamond crystals, often visible at the leading edge and sides of the rim/segment, remove material by scratching out particles of hard, dense materials, or by knocking out larger particles of loosely bonded abrasive material. This process eventually cracks or fractures the diamond particle, breaking it down into smaller pieces. As a result, a diamond blade for cutting soft, abrasive material must have a hard metal matrix composition to resist this erosion long enough for the exposed diamonds to be properly utilized. Conversely, a blade for cutting a hard, non-abrasive material must have a soft bond to ensure that it will erode and expose the diamonds embedded in the matrix. These simple principles are the foundation of “controlled bond erosion”.



#### Types of Cutting:

There are two basic types of cutting-Dry or Wet. The choice of which type of blade to use depends on:

- The requirements of the job
- The machine/tool utilizing the diamond blade
- The preference of the operator







In the case of DRY cutting, the overwhelming popularity and quantity of hand-held saws and the flexible nature of MK Diamond blades to professionally handle most ceramic, masonry, stone and concrete materials, make the DRY cutting blade a very attractive tool. When using a DRY blade, the user must be aware of distinct operating practices to ensure optimum performance. DRY cutting blades require sufficient airflow about the blade to prevent overheating of the steel core. This is best accomplished by shallow, intermittent cuts of the material with periods of “free-spinning” (for several seconds) between each cut, to maximize the cooling process.

For WET cutting applications, MK has the exact blade to compliment both the material to be cut and the wet cutting machine to be used. During cutting operations, liberal amounts of water act as a coolant to support the cutting effectiveness and longevity of the WET blade. Additionally, using water adds to the overall safety of cutting operations by keeping the dust signature down.

Know All You Can About the Material You Wish to Cut

## ACCESSORIES

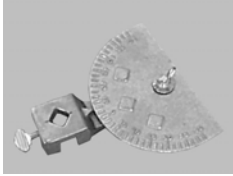
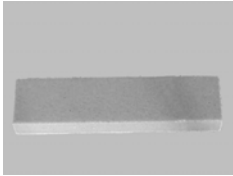
### ACCESSORIES:

ITEM	NUMBER	DESCRIPTION	
1.	137166	MK-200, 10 x 5/8 Arbor	
2.	128074	MK-215, 10 x 5/8 Arbor	
3.	153252	MK-315, 10 x 5/8 Arbor	
4.	134577	Dual 45° Flat Angle Guide	
6.	134569	90° Protractor	
7.	152792	Dressing Stone	
8.	152610	Ground Fault Circuit Interrupter	
9.	151889	Universal Stand	

## **ORDERING and RETURN INFORMATION**

### **ORDERING INFORMATION:**

You may order MK Diamond products through your local MK Diamond distributor or, you may order direct from MK Diamond.

NOTE: There is a \$25.00 minimum order when ordering direct from MK Diamond. All purchases must be made using VISA or MasterCard.

When ordering direct from MK Diamond, please have the following information ready before calling:

- The Model Number of the saw
- The Serial Number of the saw
- Where the saw was purchased and when
- The Part Number for the part(s) being ordered
- The Part Description for the part(s) being ordered

All parts may be ordered by calling toll free 1 - **800 421-5830** or **310 539-5221** and asking for Customer Service. For technical questions, call – **800 474-5594**.

### **RETURN MATERIALS POLICY:**

To expedite the service relative to the return of a product purchased through MK Diamond, please observe the following:

NOTE: When returning all items, they must have been purchased within the previous twelve (12) months.

- Have the Model Number of the saw
- Have the Serial Number of the saw
- Have the location of where the saw was purchased
- Have the date when the saw was purchased
- Contact Customer Service for approval to return the item(s)
- Obtain a Returned Goods Number (RGA) authorizing the return
- Follow the packaging instructions in the following section
- Ensure your item(s) are prepaid to the destination

For returned items, call toll free to – **800 421-5830** or **310 539-5221** and ask for Customer Service. For technical questions, call – **800 474-5594** or **310 257-2845**.

### **PACKAGING INSTRUCTIONS:**

- Remove the Blade guard and Support Angle Assembly
- Dry the saw before shipping
- When packing, include the following: MK-101 TRACKER, Diamond Blade, Blade guard and Support Angle Assembly and Adjustable Cutting Guide (Other Accessories are not required)
- Package the unit in its original container or one of comparable size (do not ship the unit partially exposed)
- Ensure all parts are secured in the packaging to prevent moving

### **AUTHORIZED SERVICE CENTERS:**

For quicker repair time, you may contact MK Diamond Customer Service, toll free, at – **800 421-5830** or **310 539-5221** for the Authorized Service Center closest to you. For technical questions, call – **800 474-5594**.

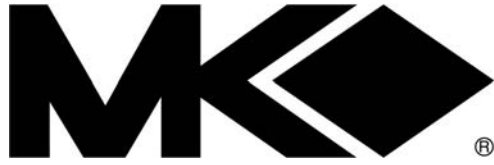

# MK-101 TRACKER

## TILE SAW OWNER'S MANUAL & OPERATING INSTRUCTIONS

### **CALIFORNIA PROPOSITION 65 MESSAGE:**

#### **⚠️ WARNING**

Some dust created by power sanding, sawing, grinding, drilling, and other construction activities contain chemicals known [to the State of California] to cause cancer, birth defects or other reproductive harm. Some examples of these chemicals are:

- Lead, from lead-based paints
- Crystalline silica, from bricks and cement and other masonry products and
- Arsenic and chromium, from chemically treated lumber

Your risk from these exposures varies depending on how often you do this type of work. To reduce your exposure to these chemicals, work in a well-ventilated area, and work with approved safety equipment, such as those dust masks that are specially designed to filter out microscopic particles.

**MK DIAMOND PRODUCTS, INC**  
**1315 STORM PARKWAY, TORRANCE, CA 90509-2803**  
**310 539 5158**