



MK Diamond Products, Inc.

www.mkdiamond.com

MK-112 TILE SAW OWNERS MANUAL & OPERATING INSTRUCTIONS



Revision 202	02.2004

Caution: Read all safety and operating instructions before using this equipment. This parts list **MUST** accompany the equipment at all times.



MK Diamond Products, Inc.

SAFETY INSTRUCTIONS FOR THE MK-112 TILE SAW

Congratulations on your purchase of a MK-112 Tile Saw. We are certain that you will be pleased with your purchase. MK Diamond takes pride in producing the finest construction power tools and diamond blades in the industry.

Operated correctly, your MK-112 should provide you with years of service. In order to help you, we have included this manual. This owners manual contains information necessary to operate and maintain your MK-112 safely and correctly. Please take a few minutes to familiarize yourself with the MK-112 by reading and reviewing this manual.

If you should have questions concerning your MK-112, please feel free to call our friendly customer service department at: 800 421-5830

Regards,

MK Diamond

SAFETY

DAMAGE PREVENTION AND INFORMATION MESSAGES _____ 4
 SAFETY MESSAGES _____ 4
 GENERAL SAFETY PRECAUTIONS AND HAZARD SYMBOLS _____ 4
 CALIFORNIA PROPOSITION 65 MESSAGE _____ 6
 ELECTRICAL REQUIREMENTS AND GROUNDING INSTRUCTIONS ___ 8
 TILE SAW SPECIFIC WARNINGS _____ 10
 SAFETY LABEL LOCATIONS _____ 10
 PRODUCT SPECIFICATIONS _____ 11

UNPACKING, TRANSPORT and ASSEMBLY

UNPACKING _____ 12
 CONTENTS _____ 12
 TRANSPORT _____ 12
 ASSEMBLY _____ 13

SETUP, ADJUSTMENT & OPERATION

SETUP _____ 14
 ADJUSTMENT & OPERATION _____ 16
 CLEANUP _____ 18

MAINTENANCE AND TROUBLESHOOTING

MAINTENANCE _____ 19
 TROUBLESHOOTING _____ 21

EXPLODED VIEW AND PARTS LIST

EXPLODED VIEW _____ 22
 PARTS LIST _____ 23

THEORY

THEORY OF DIAMOND BLADES _____ 26
 ACCESSORIES _____ 26

ORDERING & RETURN INSTRUCTIONS

ORDERING INFORMATION _____ 27
 RETURN MATERIALS POLICY _____ 27
 PACKAGING INSTRUCTIONS _____ 27
 AUTHORIZED SERVICE CENTERS _____ 27

SAFETY

Read and follow all safety, operating and maintenance instructions. Failure to read and follow these instructions could result in injury or death to you or others. Failure to read and follow these instructions could also result in damage and/or reduced equipment life.

SAFETY MESSAGES:

A safety message alerts you to potential hazards that could hurt you or others. Each safety message is preceded by a safety alert symbol () and one of three words: **DANGER**, **WARNING**, or **CAUTION**.

DANGER

You **WILL** be **KILLED** or **SERIOUSLY INJURED** if you do not follow directions.

WARNING

You **CAN** be **KILLED** or **SERIOUSLY INJURED** if you do not follow directions.

CAUTION

You **CAN** be **INJURED** if you do not follow directions. It may also be used to alert against unsafe practices.

DAMAGE PREVENTION AND INFORMATION MESSAGES:

A Damage Prevention Message is to inform the user of important information and/or instructions that could lead to equipment or other property damage if not followed. Information Messages convey information that pertains to the equipment being used. Each message will be preceded by the word **NOTE**, as in the example below.

NOTE: Equipment and/or property damage may result if these instructions are not followed.

GENERAL SAFETY PRECAUTIONS AND HAZARD SYMBOLS:

In order to prevent injury, the following safety precautions and symbols should be followed at all times!

Safety Precautions:



ALWAYS read this Owner's Manual before operating the machine.



ALWAYS keep the Blade Guards in place.



REMOVE ADJUSTING KEYS AND WRENCHES

Form a habit of checking to see that keys and adjusting wrenches are removed from the power tool before it is turned on.



KEEP WORK AREA CLEAN

Cluttered work areas and benches invite accidents.



DO NOT USE IN DANGEROUS PLACES

DO NOT use power tools in damp or wet locations nor expose them to rain. Always keep the work area well lighted.



KEEP CHILDREN AWAY

All visitors and children should be kept a safe distance from work area.

**MAKE THE WORKSHOP KID PROOF**

Make the workshops kid proof by using padlocks, master switches or by removing starter keys.

**DO NOT FORCE THE TOOL**

A power tool will do a job better and safer operating at the rate for which it was designed.

**USE THE RIGHT TOOL**

DO NOT force a tool or an attachment, to do a job that it was not designed to do.

**USE THE PROPER EXTENTION CORD**

If using an extension cord make sure it is in good condition first. When using an extension cord, be sure to use one heavy enough to carry the current your product will draw. An undersized cord will cause a drop in line voltage that will result in a loss of power and overheating. TABLE 1, Page 9 shows the correct AWG size to use depending on cord length and nameplate ampere rating. If in doubt, use the next heavier gage. The smaller the gage number, the heavier the cord.

**USE PROPER APPAREL**

DO NOT wear loose clothing, gloves, neckties, rings, bracelets, or other jewelry that may be caught in moving parts. Non-slip footwear is recommended. Wear protective hair covering to contain long hair.



ALWAYS wear approved eye protection.



ALWAYS wear approved respiratory protection.

**SECURE WORK**

Clamps or a vise should be used to hold work whenever practical. Keeping your hands free to operate a power tool is safer.

**DO NOT OVERREACH**

Keep proper footing and balance at all times by not overreaching.

**MAINTAIN TOOLS WITH CARE**

Keep tools clean for the best and safest performance. Always follow maintenance instructions for lubricating, and when changing accessories.

**DISCONNECT TOOLS**

Power tools should always be disconnected before servicing or when changing accessories, such as blades, bits, cutters, and the like.



ALWAYS place the power ON/OFF switch in the **OFF** position when the saw is not in use.

SAFETY



USE RECOMMENDED ACCESSORIES

Consult the owner's manual for recommended accessories. Using improper accessories may increase the risk of personal or by-stander injury.



NEVER STAND ON THE TOOL

Serious injury could occur if a power tool is tipped, or if a cutting tool is unintentionally contacted.



CHECK FOR DAMAGED PARTS

Before using a power tool, check for damaged parts. A guard or any other part that is damaged should be carefully checked to determine it would operate properly and perform its intended function. Always check moving parts for proper alignment or binding. Check for broken parts and mountings and all other conditions that may affect the operation of the power tool. A guard, or any damaged part, should be properly repaired or replaced.



DIRECTION OF FEED

ALWAYS feed work into a blade or cutter against the direction of rotation. A blade or cutter should always be installed such that rotation is in the direction of the arrow imprinted on the side of the blade or cutter.



NEVER LEAVE A TOOL UNATTENDED

TURN POWER OFF - Do not leave a tool until it comes to a complete stop. Always turn a power tool OFF when leaving the work area, or, when a cut is finished.

CALIFORNIA PROPOSITION 65 MESSAGE:



WARNING

Some dust created by power sanding, sawing, grinding, drilling, and other construction activities contain chemicals known [to the State of California] to cause cancer, birth defects or other reproductive harm. Some examples of these chemicals are:

- Lead, from lead-based paints
- Crystalline silica, from bricks and cement and other masonry products and
- Arsenic and chromium, from chemically treated lumber

For further information, consult the following sources:

<http://www.osha.gov/SLTC/silicacrystalline/index.html>

http://www.oehha.org/prop65/out_of_date/6022kLstA.html

Your risk from these exposures varies depending on how often you do this type of work. To reduce your exposure to these chemicals, work in a well-ventilated area, and work with approved safety equipment, such as those dust masks that are specially designed to filter out microscopic particles.

Hazard Symbols:**ELECTRICAL SHOCK**

NEVER touch electrical wires or components while the engine is running. They can be sources of electrical shock which could cause severe injury or burns.

**ROTATING PARTS**

Keep hands, feet, hair, and clothing away from all moving parts to prevent injury. Never operate the engine with covers, shrouds, or guards removed.

**OVER SPEED**

NEVER tamper with the governor components or settings to increase the maximum speed. Severe personal injury and damage to the engine or equipment can result if operated at speeds above maximum.

**DO NOT EXPOSE TO RAIN**

DO NOT expose to rain or use in damp locations.

**WARNING**

Sawing and drilling generates dust. Excessive airborne particles may cause irritation to eyes, skin and respiratory tract. To avoid breathing impairment, always employ dust controls and protection suitable to the material being sawed or drilled; See OSHA (29 CFR Part 1910.1200). Diamond Blades improperly used are dangerous. Comply with American National Standards Institute Safety Code, B7.1 and, Occupational Safety and Health Act covering Speed, Safety Guards, Flanges, Mounting Procedures, General Operating Rules, Handling, Storage and General Machine Conditions

SAFETY

ELECTRICAL REQUIREMENTS AND GROUNDING INSTRUCTIONS:

In order to prevent potential electrical shock and injury, the following electrical safety precautions and symbols should be followed at all times!

WARNING



In case of a malfunction or breakdown, grounding provides a path of least resistance for electric current to reduce the risk of electric shock. This tool is equipped with an electric cord having an equipment-grounding conductor and a grounding plug. The plug must be plugged into a matching outlet that is properly installed and grounded in accordance with all local codes and ordinances.

- Do not modify the plug provided – if it will not fit the outlet; have the proper outlet installed by a qualified electrician
- Improper connections of the equipment-grounding conductor can result in a risk of electric shock. The equipment-grounding conductor is the insulated conductor that has an outer surface that is green, with or without yellow stripes. If repair or replacement of the electric cord or plug is necessary, do not connect the equipment-grounding conductor to a live terminal
- Check with a qualified electrician or service personnel if the grounding instructions are not completely understood, or if in doubt as to whether the tool is properly grounded
- Use only 3-wire extension cords that have 3-prong grounding plugs and 3-pole receptacles that accept the tool's plug
- Repair or replace a damaged or worn cord immediately

WARNING



This tool is intended for use on a circuit that has an outlet that looks like the one shown in Sketch A of Figure 1. The tool has a grounding plug that looks like the plug illustrated in Sketch A of FIGURE 1. A temporary adapter, which looks like the adapter illustrated in sketches B and C, may be used to connect

this plug to a 2-pole receptacle as shown in Sketch B, if a properly grounded outlet is not available. The temporary adapter should be used only until a properly grounded outlet can be installed by a qualified electrician. The green-colored rigid ear, lug, and the like, extending from the adapter, must be connected to a permanent ground such as a properly grounded outlet box.

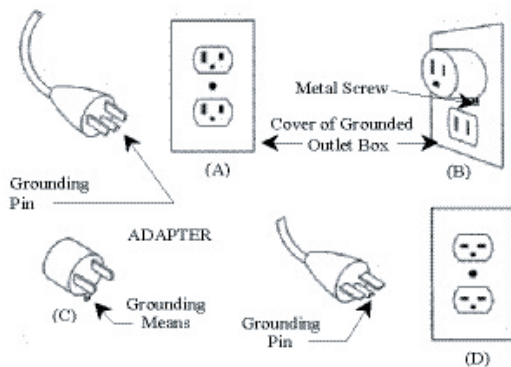

FIGURE 1

NOTE: Use of a temporary adapter is not permitted in Canada

WARNING

To reduce the risk of electrocution, keep all connections dry and off the ground.

A Ground Fault Circuit Interrupter (GFCI) should be provided on the circuit(s) or outlet(s) to be used for the Saw. Receptacles are available having built-in GFCI protections and may be used for this measure of safety.

When using an extension cord, the GFCI should be installed closest to the power source, followed by the extension cord and lastly, the saw.

To avoid the possibility of the appliance plug or receptacle getting wet, position the saw to one side of a wall mounted receptacle. This will prevent water from dripping onto the receptacle or plug. A “drip loop,” shown in FIGURE 2, should be arranged by the user to properly position the power cord relative to the power source.

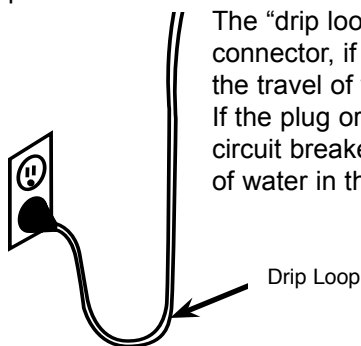

The “drip loop” is that part of the cord below the level of the receptacle, or the connector, if an extension cord is used. This method of positioning the cord prevents the travel of water along the power cord and coming in contact with the receptacle. If the plug or receptacle gets wet, DO NOT unplug the cord. Disconnect the fuse or circuit breaker that supplies power to the tool. Then unplug and examine for presence of water in the receptacle.

FIGURE 2

! WARNING



Use only extensions cords that are intended for outdoor use. These extension cords are identified by a marking “Acceptable for use with outdoor appliances; store indoors while not in use.” Use only extension cords having an electrical rating not less than the rating of the product. Do not use damaged extension cords. Examine extension cords before using and replace if damaged. Do not abuse extension cords and do not yank on any cord to disconnect. Keep cords away from heat and sharp edges. Always disconnect the extension cord from the receptacle before disconnection the product form the extension cord.

! WARNING

To reduce the risk of electrocution, keep all connections dry and off the ground. Do not touch the plug with wet hands.

! WARNING



Use of under size extension cords result in low voltage to the motor that can result in motor burnout and premature failure. MK Diamond warns that equipment returned to us showing signs of being run in a low voltage condition, through the use of undersized extension cords will be repaired or replaced totally at the customers expense. There will be no warranty claim.

To choose the proper extension cord,

- Locate the length of extension cord needed in TABLE 1 below.
- Once the proper length is found, move down the column to obtain the correct AWG size required for that length of extension cord.

Extension Cord Minimum Gage for Length				
Volts	Total Length of Cord in Feet			
120 V	25 ft.	50 ft.	100 ft.	150 ft.
	AWG	AWG	AWG	AWG
	14	12	Not Recommended	

TABLE 1

SAFETY

SAFETY LABEL LOCATIONS

Safety labels are located according to Figures 1 through 3 below. The labels contain important safety information. Please read the information contained on each safety label. These labels are considered a permanent part of your saw. If a label comes off or becomes hard to read, contact MK Diamond or your dealer for a replacement

Item	Location	Description	Part No.
1A	Rail – Top/Left Upper	Caution – Use with Ground Fault Circuit Interrupter	155678
1B	Rail – Top/Left Lower	Warning – Read Owners Manual	155806
2	Water Pan – Back/Left	MK-112 Serial Number	160469
3	Water Pan – Back/Right	MK Service Information	155038
4	Water Pan – Front	MK-112 Title	160468

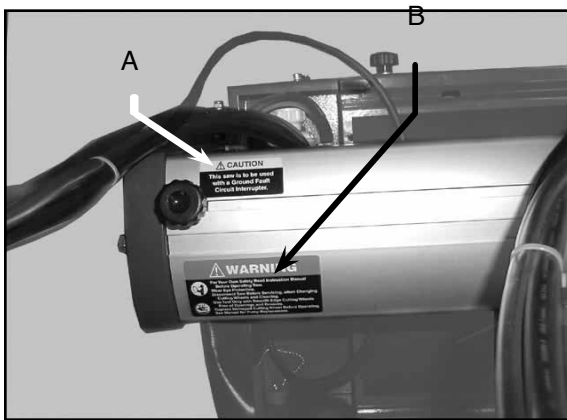

1

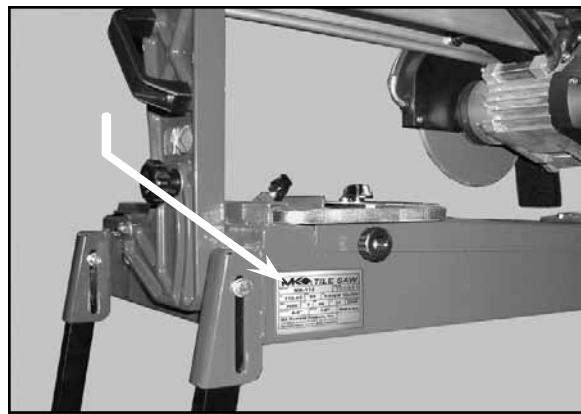

2

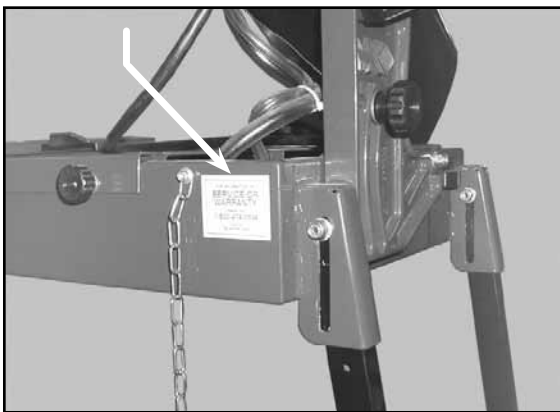

3

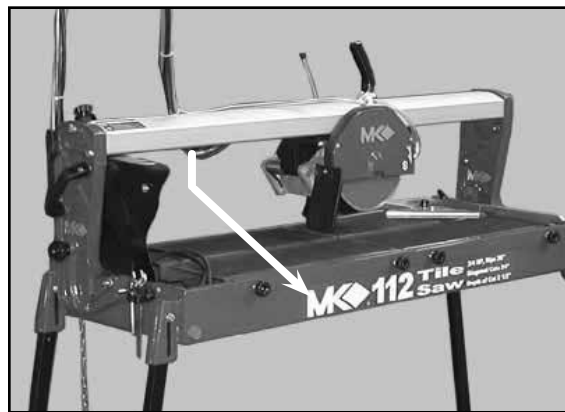

4

TILE SAW SPECIFIC WARNINGS:



WARNING

Wear eye protection.

Use splash hood for every operation for which it can be used.

Disconnect saw before servicing, when changing cutting blades, and cleaning.

Replace damaged cutting blade before operating.

PRODUCT SPECIFICATIONS

The MK-112 is a versatile Tile Saw. Operated and used according to this manual, the MK-112 will provide years of dependable service.

General Description

The saw includes a powerful 115V electric motor. It is capable of cutting tile up to thirty-six (36) inches in length and twenty four (24) inches diagonally. For cuts at 45°, the saw can cut to a depth of 1-3/4" and for cuts at 90° it can cut up to a depth of 2-1/2".

Motor Specifications

Motor specifications for the MK-112 are listed in Table 2 below.

Voltage	115V
Power Consumption	650W
Frequency	60Hz
RPM	3400 rpm
Horse Power	1 hp

TABLE 2

Blade Capacity:

The MK-112 uses a eight (8) inch (203mm) diameter, wet cutting continuous rim, MK Diamond blade with a seven-eighths (7/8) inch (22.225 mm) arbor.

Tile Types:

The MK-112 can cut a variety of tile types including stone, masonry, and lapidary products.

NOTE: The MK-112 is not designed to cut plastic, wood or metals.

UNPACKING, TRANSPORT and ASSEMBLY

UNPACKING

⚠ CAUTION Use proper lifting techniques when lifting the MK-112
If not done yet, remove the MK-112 Saw and accessory box from the carton.

CONTENTS

In your container, you will find

- A. One (1) MK-112 Saw
- B. One (1) 8-inch wet cutting continuous rim blade,
- C. One (1) Water Pump
- D. One (1) 5mm wrench
- E. One (1) 19mm wrench
- F. One (1) 5mm Allen key
- G. One (1) Protractor/Cutting guide
- H. One (1) Side Table
- I. One (1) owners manual and
- J. One (1) warranty card.



A



B



C

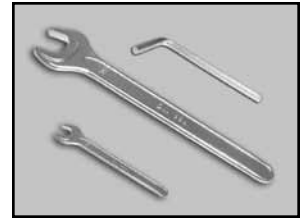

D,E,F

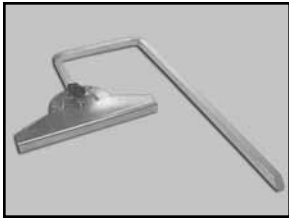

G



H



I



J

TRANSPORT:

⚠ CAUTION 1. The MK-112 weighs approximately ninety-one (96) pounds; use care when transporting.
2. Never transport the MK-112 with water in the water pan.

The MK-112 is easy to carry by using the specially provided side handles.

Before carrying the machine make sure that:

- * the motor slide is locked in place with the two Cutting Adjustment Knobs on the slide rail;
- * the motor slide is completely lowered and locked with the locking lever;
- * the machine is in the 45° position and that the Angle Adjustment Knobs are properly tightened;
- * the feet are closed and the leg lock pin inserted.

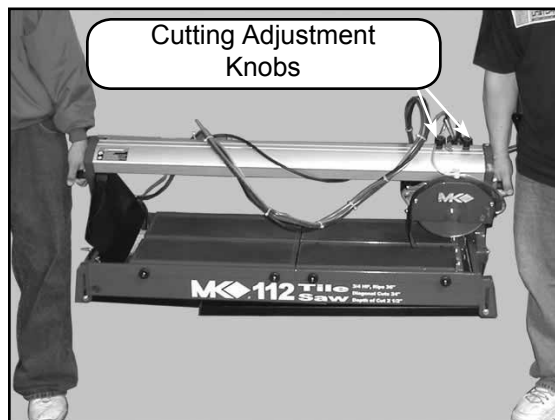

ASSEMBLY:

Remove the machine from the packaging with the aid of the side carrying handles.

To set up the machine for work proceed as follows:

1. Remove the leg lock pin and raise the rear side (pump side) of the machine with the handle until the leg is fully extended (See Picture 1).



PICTURE 1

2. Raise the leg by sliding it inside the slot.



PICTURE 2

3. Repeat the operation for the front side of the machine (See Picture 2)
4. Insert the tube-holder rod in its seat (See Picture 3).



PICTURE 3

Should it be necessary to disassemble the machine, carry out the above operations in reverse order.

SETUP, ADJUSTMENT & OPERATION

SETUP:

Follow the assembly instructions to prepare your MK-112 for operation.

1. Checking before use:

! CAUTION THE MK-112 TILE SAW IS DESIGNED TO WORK WITH WATER
Before any cutting operation, make sure that the water level inside the water pan reaches the pump.

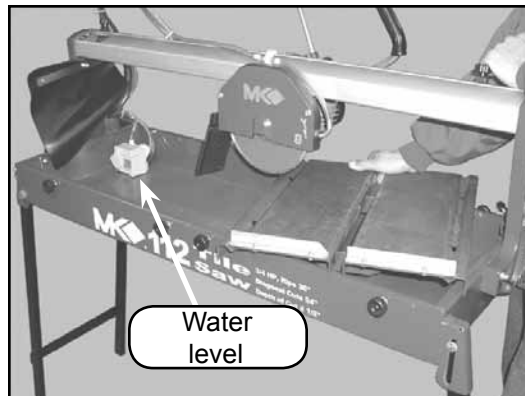

PICTURE 4

! CAUTION ADJUSTMENT OF COOLING WATER

Through an on-off valve placed on the disk protection (SEE PICTURE 5) it is possible to adjust the water flow according to the type of material to be cut. An innovative cooling system makes it possible and allows the blade to be always wet.

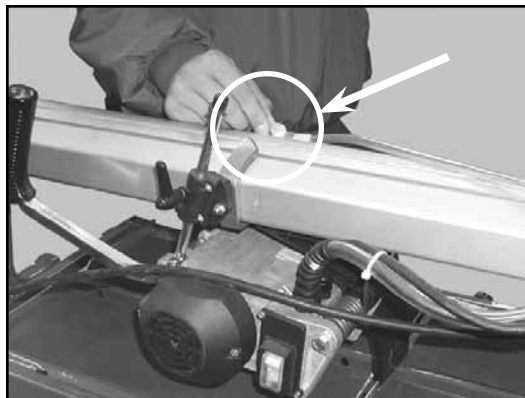

PICTURE 5

SETUP, ADJUSTMENT & OPERATION

3. MK-112 Setup for Operation

- CAUTION**
1. Before powering or starting, check for damage that could prevent this equipment from proper operation or performing its intended function. Check for binding and alignment of moving parts. Check for damaged, broken, or missing parts.
 2. Verify the On/Off switch is in the OFF position.
 3. Before connecting the MK-112 to a power supply, be sure the voltage, cycle and phase of the job site power source meet the requirements of TABLE 3

VOLTAGE	115V
CYCLE	60Hz
PHASE	1-phase

TABLE 3

4. Use an approved Ground Fault Circuit Interrupter (GFCI)
5. Do not cover the motor vents as this could lead to motor overheating.

- NOTE:**
1. In order to avoid breaker tripping, a 20-amp circuit breaker should be used.
 2. If using an extension power cord, make sure the length and wire gauge correspond to the requirements listed in TABLE 1 on page 9. An extension power cord that is too small in wire gauge (diameter), or too long in length, will cause the motor to overheat and could cause premature failure.



(A)
Plug MK-112 into the GFCI



(B)
Plug the GFCI into the Power source

SETUP, ADJUSTMENT & OPERATION

ADJUSTMENT & OPERATION

1. Cutting at 90°:

⚠ CAUTION DO NOT FORCE THE TOOL. It will do the job better and safer at the rate for which it was designed.

Thanks to the great versatility of the MK-112 Saw it is possible to carry out different types of cuts. Take the blade to the 0° position with the angle adjustment knobs (See PICTURE 6). Position the tile on the support table and make sure that it is properly positioned against the cutting guide.

⚠ CAUTION THE RULER PLACED ON THE WORKING TABLE HELPS ONLY WITH RIP CUTTING

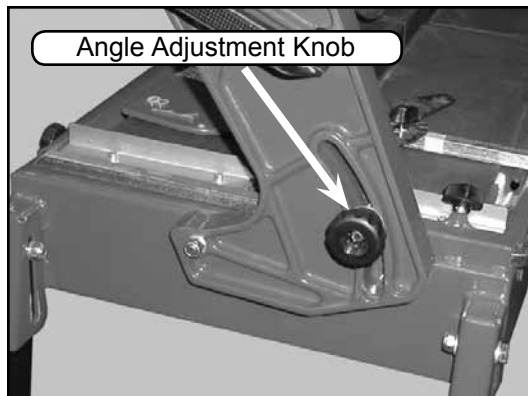

PICTURE 6

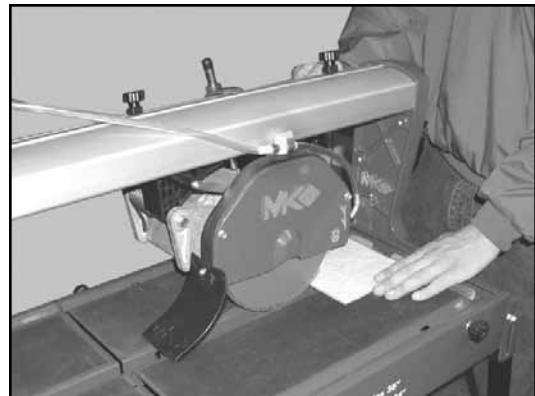

PICTURE 7

In order to make any diagonal cuts, position the tile against the cutting guide as shown in PICTURE 8.

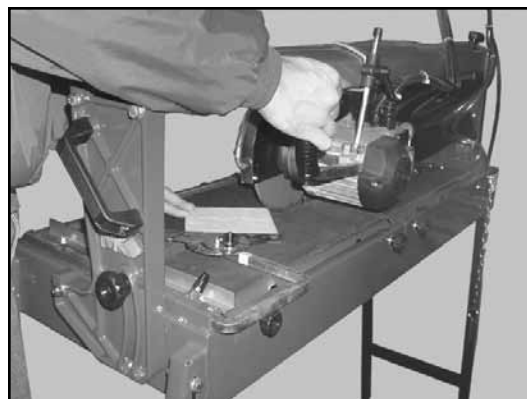

PICTURE 8

SETUP, ADJUSTMENT & OPERATION

2. Cutting 45° Miters:

The MK-112 is designed with an adjustable Cutting Head for precision 45° Miter Cuts.

⚠ CAUTION DO NOT FORCE THE TOOL. It will do the job better and safer at the rate for which it was designed.

Take the blade to the 45° position with the Angle Adjustment Knobs (See picture 11). Lock the motor carriage at the max. cutting depth with the locking lever (See Picture 10). Picture 10 shows the proper way the machine should be used.

With the MK-112 Saw, it is possible to set out:

- the cutting length with the cut length adjustment knobs (See PICTURE 9)
- the cutting depth with the locking lever (See picture 10)

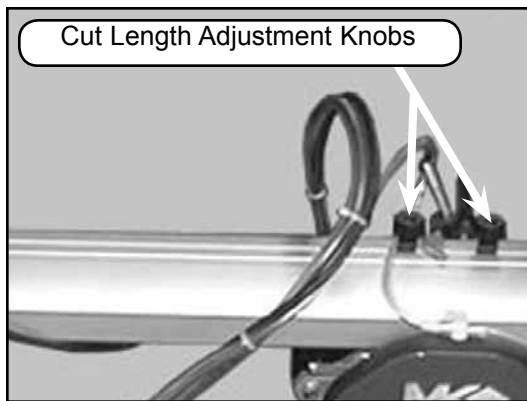

PICTURE 9

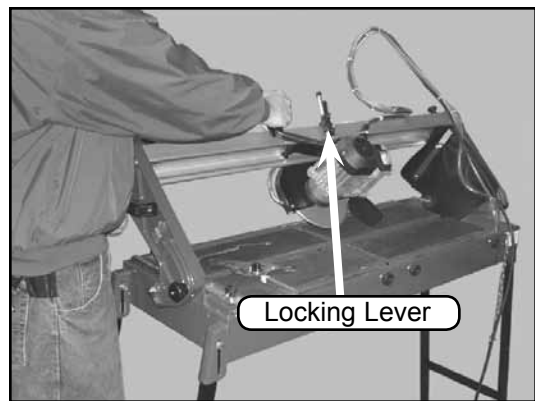

PICTURE 10

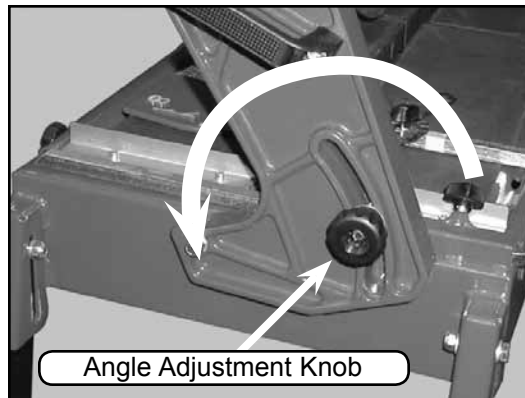

PICTURE 11

⚠ CAUTION Before any cutting, make sure that the tile to be cut is properly positioned against the cutting guide.

SETUP, ADJUSTMENT & OPERATION

CLEANUP

To clean the MK-112 Saw loosen the Side Knobs and remove the support tables.

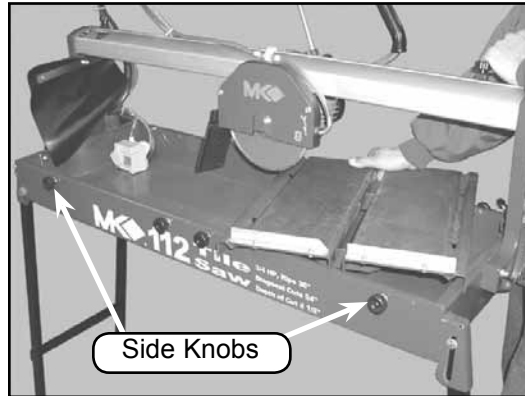

PICTURE 12

When necessary clean the water nozzles as shown in pictures 13 and 14.



PICTURE 13



PICTURE 14

Clean the remainder of the MK-112



PICTURE 15

MAINTENANCE

1. Disassembly of the Diamond Blade:

Loosen the two nuts on the blade guard and remove it. Remove the blade shaft nut with a 19mm wrench and a 5mm Allen key (provided).

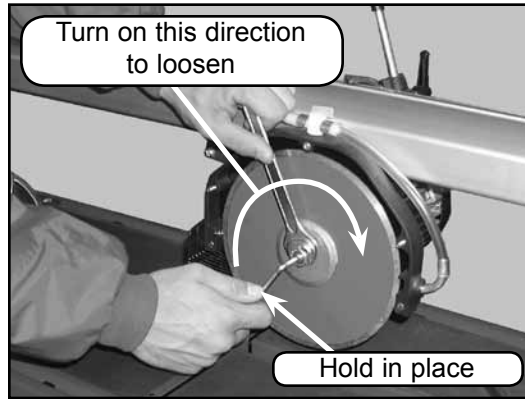

PICTURE 16

! CAUTION THE BLADE SHAFT NUT HAS A LEFT-HAND THREAD.

After dismantling the blade guard assembly, clean the blade flanges carefully and check them for wear. You can now install the new blade. Proceed to re-assemble the blade guard assembly and check for correct direction of rotation as clearly indicated on the tool.

2. Motor Carriage Adjustment:

The motor carriage is provided with a register for the vertical play adjustment. If any excessive play of the motor carriage should take place, act as follows:

1. Loosen the adjustment lock nut with a 10mm wrench (not provided);
2. Screw down the dowel with a 3mm Allen key (not provided) until the play is eliminated;
3. Tighten the adjustment lock nut.



PICTURE 17

MAINTENANCE AND TROUBLESHOOTING

3. Blade Dressing

Like most cutting tools, a diamond blade performs best when it is dressed. Over time and use, diamonds on the outer edge of the blade will become smoothed or “glazed” over.

This will reduce grinding efficiency and may cause the blade to “wander” or bend giving the illusion of an alignment problem. When this occurs, the blade will need to be dressed.

The diamond blade can be dressed using the MK Dressing Stick (part number 152792) and by following the steps below.



(A)
Setup the MK-112 for
operation

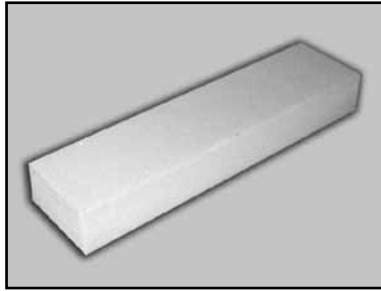

(B)
Position the Dressing Stick

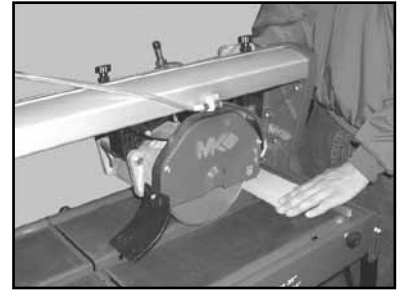

(C)
Cut the Dressing Stick 7 or 8
times to dress the Blade

MAINTENANCE AND TROUBLESHOOTING

TROUBLESHOOTING

HAVE YOUR TOOL REPAIRED BY A QUALIFIED PERSON

This electric tool complies with the relevant safety rules. Repairs should only be carried out by qualified persons using original spare parts, otherwise this may result in considerable danger to the user.

PROBLEM	CAUSE	SOLUTION
The machine does not work.	The power supply cable is damaged or not properly connected.	Press the plug firmly into the power socket. Check the power supply cable.
	No voltage in the socket.	Have the socket checked.
	Control switch is damaged.	Consult local dealer for replacement
If water does not flow at the blade with the pump running.	The sprayer unit is clogged.	Dismantle the sprayer assembled inside the blade and remove any possible residuals.
Motor gives off unpleasant odor.	Water may have seeped through inside the motor.	Unplug the power supply cable and consult local dealer.
	Capacitor is damaged	Unplug the power supply cable and consult local dealer.
Machine is difficult to start.	Motor bearings are damaged.	Unplug the power supply cable and consult local dealer.

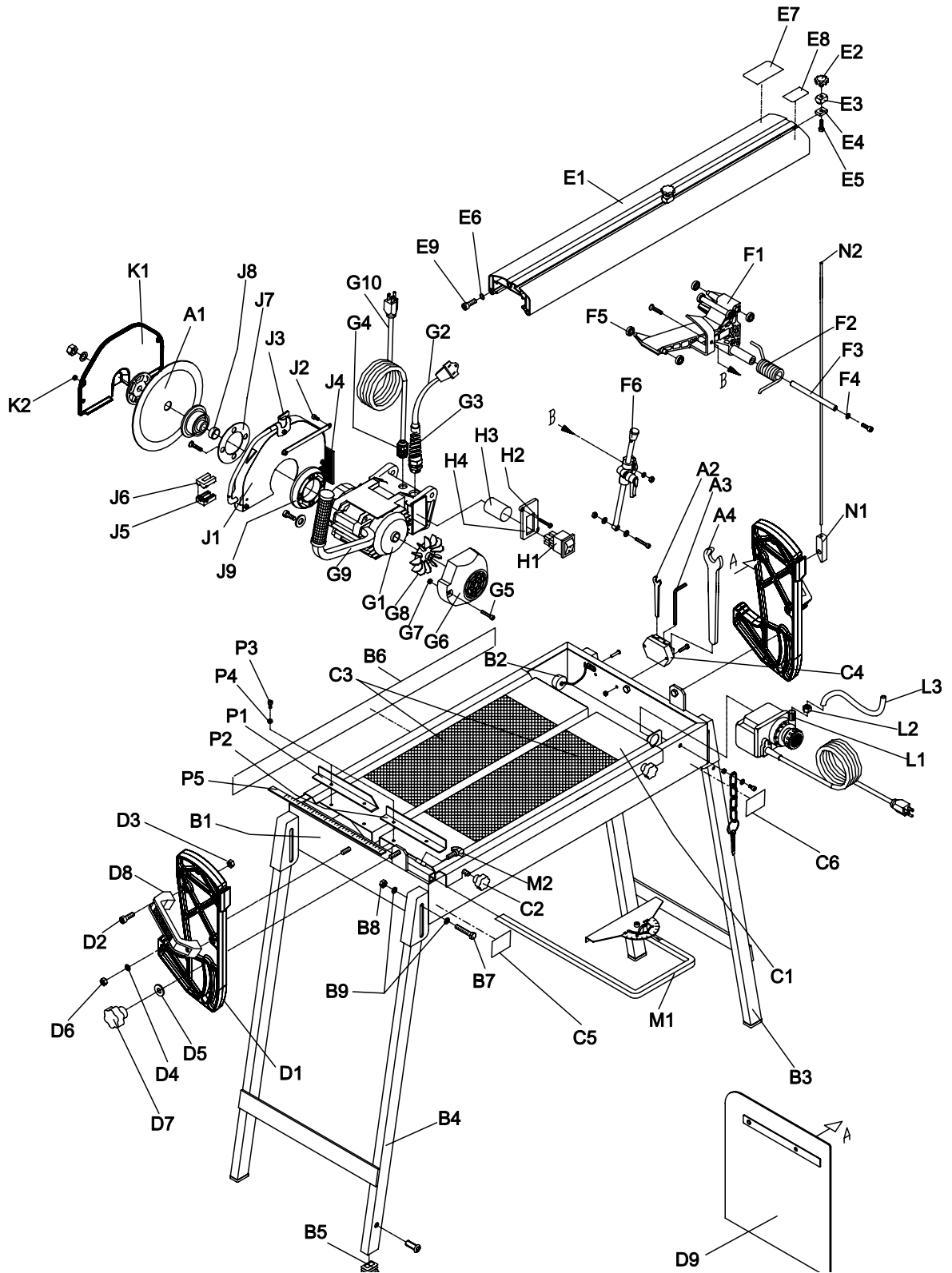

EXPLODED VIEW

PARTS LIST:

Item	Description	Qty	MK Part #
A Assembly, Accessories			
A1	Blade, MK-200, 8x7/8 Arbor	1	137158Y
A2	5mm wrench	1	160529
A3	5mm Allen key	1	159979
A4	19mm wrench	1	160530
A5	Card, MK Warranty Registration (not shown)	1	155037
A6	Manual, MK-112 Owners (not shown)	1	160467
A7	Label, Do Not Return (not shown)	1	157063
B Assembly, Frame/Pan			
B1	Frame / Pan Weldment	1	160531
B2	Plug, Rubber Drain	1	160532
B3	Leg, Stand LT	1	160533
B4	Leg, Stand RT	1	160534
B5	Foot, Rubber	4	160535
B6	Label, MK-112 Title	1	160468
B7	Screw, Hex HD 5/16-18X1-1/2	4	152467
B8	Nut, Hex Nylock	4	158289
B9	Washer, 5/16 SAE Flat	8	151754
C Assembly, Table			
C1	Table, MK 112	2	160536
C2	Knob, MK 112 Table	4	160537
C3	Mats, MK 112 Table	4	160538
C4	Holder, Accessory	1	160539
C5	Label, Serial #, MK-112	1	160469
C6	Label, MK Service Info. 2 1/8 X 1-13/16	1	155038
D Assembly, Pivot Post			
D1	Post, 112 (comp)	2	160466
	Post, 112 (raw)	2	160417
D2	Screw, Soc HD Cap M8X1.25X50MM	4	160540
D3	Nut, Hex Flange M8		156624
D4	Washer, 5/16 SAE Flat	2	151754
D5	Washer, Fender 5/16 IDX 1.0 OD	2	151053
D6	Nut, Hex Nylock 5/16-18	2	158289
D7	Knob, 3/16-18 MK Angle Adjustment	2	160541
D8	Handle, MK 112	2	160542
D9	Guard, Large Splash	1	160543
E Assembly, Rail			
E1	Rail, MK 112	1	160544
E2	Knob, MK 112 Cut Length Adjustment	2	160545
E3	Spacer, Length Adjustment	2	160546
E4	Guide, Length Adjustment	2	160547
E5	Screw, Hex HD M6 x 20mm	2	158158
E6	Wawher, Lock Split 5/16	6	151747
E7	Label, Warning, Read Owners	1	155806
E8	Label, Caution, GFCI	1	155678
E9	Screw, Hex HD M6 x 20mm	2	158158

MK-112 PARTS LIST (Cont...)

F	Assembly, MK 112 Cutting Head		
F1	Block, Rail Saw Bearing	1	160548
F2	Spring, Cutting Head	1	160549
F3	Shaft, Cutting Head	1	160550
F4	Washer, 5/16 SAE Flat	2	151754
F5	Bearing, Radial Ball TYPE 608 ABEC-1	6	160551
F6	Rail, Vertical Guide	1	160552
G	Assembly, 115V Motor		
G1	Motor, 115 Volt, 60Hz, 1 hp	1	160553
G2	Power, Water Pump	1	160554
G3	Relief, MK-112 Strain w/Lock Nut	1	160555
G4	Nut, Strain Relief Lock	1	160556
G5	Screw, Soc HD Cap M5 x 25mm	2	160557
G6	Cap, Motor	1	160558
G7	Nut, M5-.8 Hex	4	157405
G8	Fan, Motor	1	160559
G9	Handle, Motor	1	160560
G10	Cord, MK-112 Power	1	160561
H	Assembly, MK 112 Switch		
H1	Switch, MK 112	1	160562
H2	Screw, Pan HD PHIL 4M x 12mm	2	160563
H3	Sleeve, Wire	1	160564
H4	Plate, MK 112 Switch	1	160565
J	Assembly, Inner Blade Guard		
J1	Guard, MK 112 Inner Blade (comp)	1	160566
J2	Screw, Socket Cap M5 X 10mm	1	160567
J3	Valve, Water	1	160568
J4	Guard, Splash	1	160310
J5	Spray, Water, Bottom (Fem)	1	160569
J6	Spray, Water, Top (Male)	1	160570
J7	Spacer, Steel	1	160571
J8	Bushing, Blade Guard	1	160572
J9	Connector, Blade Guard	1	160573
K	Assembly, Blade Guard		
K1	Blade Guard, 112 (comp)	1	160438
	Blade Guard, 112 (raw)	1	160437
K2	Nut, Hex Flange M5	2	160574
L	Assembly, Water Pump		
L1	Pump, Water	1	160575
L2	Adapter, Brass	1	160576
L3	Hose, Vinyl	1	160577
M	Assembly, MK 112, Slide Protractor		
M1	Protractor, MK 112 Sub-assembly	1	160578
M2	Knob, Protractor	1	160579

MK-112 PARTS LIST (Cont...)

N	Assembly, Antenna		
N1	Holder, Antenna	1	160580
N2	Antenna	1	160581
P	Assembly, Back Stop		
P1	Stop, Left	1	160582
P2	Stop, Right	1	160583
P3	Screw, Soc HD Cap M5 x 8mm	5	160584
P4	Nut, Hex Flange M5	4	160585
P5	Ruler, Stop	1	160586
R	Assembly, Side Table		
R1	Table, MK-112 Side	1	160588
R2	Mats, MK-112 Table	3	160538
R3	Stop, Right	2	160583
R3	Screw, Soc HD Cap M5 x 8mm	4	160584
R4	Nut, Hex Flange M5	4	160585
R6	Leg, MK-112 Side Table	1	160589

THEORY

THEORY OF DIAMOND BLADES

Diamond blades do not really cut; they grind the material through friction. Diamond crystals, often visible at the leading edge and sides of the rim/segment, remove material by scratching out particles of hard, dense materials, or by knocking out larger particles of loosely bonded abrasive material.

This process eventually cracks or fractures the diamond particle, breaking it down into smaller pieces. As a result, a diamond blade for cutting soft, abrasive material must have a hard metal matrix composition to resist this erosion long enough for the exposed diamonds to be properly utilized.



Conversely, a blade for cutting a hard, non-abrasive material must have a soft bond to ensure that it will erode and expose the diamonds embedded in the matrix. These simple principles are the foundation of “controlled bond erosion”.

Types of Cutting

There are two basic types of cutting-Dry or Wet. The choice of which type of blade to use depends on:



- The requirements of the job
- The machine/tool utilizing the diamond blade
- The preference of the operator

In the case of DRY cutting, the overwhelming popularity and quantity of hand-held saws and the flexible nature of MK Diamond blades to professionally handle most ceramic, masonry, stone and concrete materials, make the DRY cutting blade a very attractive tool. When using a DRY blade, the user must be aware of distinct operating practices to ensure optimum performance. DRY cutting blades require sufficient airflow about the blade to prevent overheating of the steel core. This is best accomplished by shallow, intermittent cuts of the material with periods of “free-spinning” (for several seconds) between each cut, to maximize the cooling process.

For WET cutting applications, MK has the exact blade to compliment both the material to be cut and the wet cutting machine to be used. During cutting operations, liberal amounts of water act as a coolant to support the cutting effectiveness and longevity of the WET blade. Additionally, using water adds to the overall safety of cutting operations by keeping the dust signature down.

Know All You Can About the Material You Wish to Cut

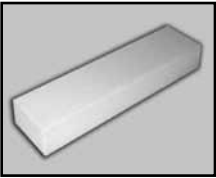
ACCESSORIES

ITEM	NUMBER	DESCRIPTION	
8.	152792	Dressing Stone	
9.	152610	Ground Fault Circuit Interrupter	

ORDERING & RETURN INSTRUCTIONS

ORDERING INFORMATION

You may order MK Diamond products through your local MK Diamond distributor or, you may order direct from MK Diamond.

NOTE: There is a \$25.00 minimum order when ordering direct from MK Diamond. All purchases must be made using VISA or MasterCard.

When ordering direct from MK Diamond, please have the following information ready before calling:

- The Model Number of the saw
- The Serial Number of the saw
- Where the saw was purchased and when
- The Part Number for the part(s) being ordered
- The Part Description for the part(s) being ordered

All parts may be ordered by calling toll free to – 800 421-5830 or 310 539-5221 and asking for Customer Service. For technical questions, call – 800 474-5594.

RETURN MATERIALS POLICY

To expedite the service relative to the return of a product purchased through MK Diamond, please observe the following:

NOTE: When returning all items, they must have been purchased within the previous twelve (12) months.

- Have the Model Number of the saw
- Have the Serial Number of the saw
- Have the location of where the saw was purchased
- Have the date when the saw was purchased
- Contact Customer Service for approval to return the item(s)
- Obtain a Returned Goods Number (RGA) authorizing the return
- Follow the packaging instructions in the following section
- Ensure your item(s) are prepaid to the destination

For returned items, call toll free to – 800 421-5830 or 310 539-5221 and ask for Customer Service. For technical questions, call – 800 474-5594 or 310 257-2845.

PACKAGING INSTRUCTIONS

- Remove the Blade guard and Support Angle Assembly
- Dry the saw before shipping
- When packing, include the following: MK-112, Diamond Blade, Blade guard and Support Angle Assembly and Adjustable Cutting Guide (Other Accessories are not required)
- Package the unit in its original container or one of comparable size (do not ship the unit partially exposed)
- Ensure all parts are secured in the packaging to prevent moving

AUTHORIZED SERVICE CENTERS

For quicker repair time, you may contact MK Diamond Customer Service, toll free, at 800 421-5830 or 310 539-5221 for the Authorized Service Center closest to you or visit our web site at www.mkdiamond.com. For technical questions, call – 800 474-5594.

MK-112 TILE SAW
OWNERS MANUAL & OPERATING INSTRUCTIONS
DOCUMENT NO. 160467
REVISION 201
02/04



MK Diamond Products, Inc.

MK Diamond Products, Inc.
1315 Storm Parkway
Torrance, CA 90501

Toll-Free: (800) 845-3729
Phone: (310) 539-2221
Fax: (310) 539-5158
www.mkdiamond.com