

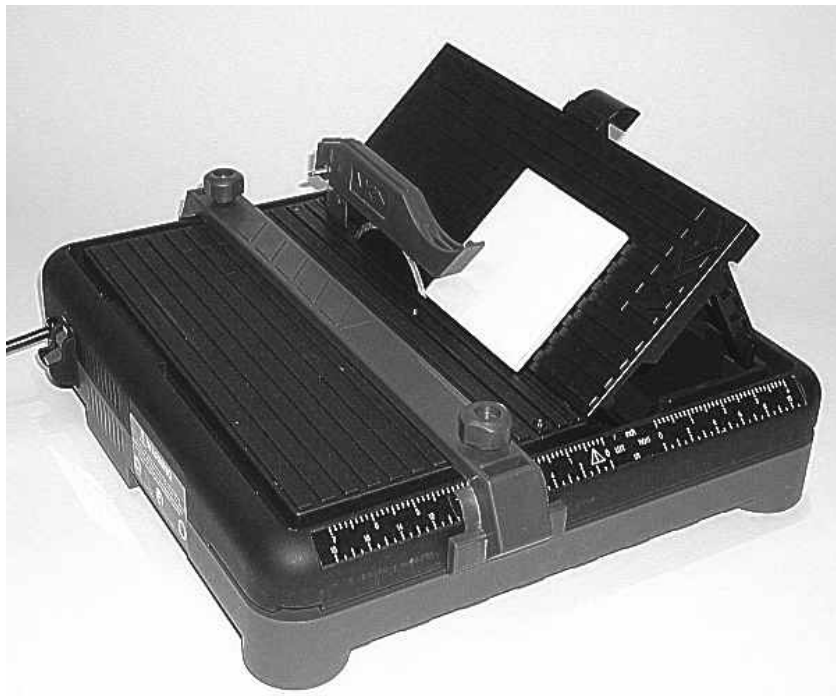

MK-145 SERIES

**TILE SAW
OWNER'S MANUAL &
OPERATING INSTRUCTIONS**



CAUTION:
READ ALL SAFETY AND
OPERATING
INSTRUCTIONS BEFORE
USING THIS EQUIPMENT.

Enter the Serial Number of your new saw in the space below. The Serial Number is located on the switch side of the unit.

SERIAL NUMBER:

NOTE:

For your (1) one year warranty to be effective, complete the warranty card (including the Serial Number) and mail it in immediately upon purchase.

INTRODUCTION:

We at MK Diamond want to congratulate you on selecting the MK-145 Tile Saw. We are certain that you will be pleased with your purchase. MK Diamond takes pride in producing the finest products in the industry.

Operated correctly, your MK-145 should provide you with years of quality service. In order to help you, we have included this owners manual and operating instructions. This owners manual contains information necessary to operate and maintain your MK-145 safely and correctly. Please review this manual until you fully understand how to operate and maintain your MK-145 Tile Saw. Failure to review and understand these instructions could result in serious damage to your tile saw and serious personal injury or death to anyone using this tile saw.

If you should have any questions concerning your MK-145, at any time please feel free to call our friendly customer service department at: (800) 421-5830.

Regards,

MK Diamond

TABLE of CONTENTS:

	Page
SAFETY:	
Safety Messages	4
Damage Prevention Message	4
General Safety Precautions and Hazard Symbols	4
California Proposition 65 Message	7
Electrical Requirements and Grounding Instructions	7
Lock Out	10
Safety Label Locations	10
Tile Saw Specific Warnings	10
Product Specifications	11
UNPACKING AND ASSEMBLY	
Unpacking	12
Contents	12
Transport	12
Assembly	13
SETUP, ADJUSTMENT AND OPERATION	
Setup	16
Adjustment and Operation	18
Cleanup	22
MAINTENANCE AND TROUBLESHOOTING	
Maintenance	23
Troubleshooting	25
EXPLODED VIEW AND PARTS LIST	
Exploded View	27
Parts List	28
THEORY	
Theory of Diamond Blades	29
ACCESSORIES ORDERING and RETURN INSTRUCTIONS	
Accessories	30
Ordering Information	31
Return Material Policy	31
Packaging Instructions	31
Authorized Service Centers	31

Manual Part No. 158550

Revision No. 09/04

SAFETY:

Read and follow all safety, operating and maintenance instructions. Failure to read and follow these instructions could result in injury or death to you or others. Failure to read and follow these instructions could also result in damage and/or reduced equipment life.

SAFETY MESSAGES:

Safety messages inform the user about potential hazards that could lead to injury, death and/or equipment damage. Each safety message will be preceded by one of the following (3) three words that identify the severity of the message.

⚠ WARNING

Not following instructions **COULD** lead to **DEATH** or **SERIOUS INJURY**

⚠ CAUTION

Not following instructions **CAN** lead to injury

DAMAGE PREVENTION AND INFORMATION MESSAGES:

A Damage Prevention Message is to inform the user of important information and/or instructions that could lead to equipment or other property damage if not followed. Information messages convey information that pertains to the equipment being used. Each message will be preceded by the word note, as in the example below.

NOTE: Equipment and/or property damage may result if these instructions are not followed.

GENERAL SAFETY PRECAUTIONS AND HAZARD SYMBOLS:

In order to prevent injury, the following safety precautions and symbols should be followed at all times!

Safety Precautions:

KEEP GUARDS IN PLACE.



In order to prevent injury, keep guards in place and in working order at all times.

REMOVE ADJUSTING KEYS AND WRENCHES.

Form a habit of checking to see that keys and adjusting wrenches are removed from the power tool before it is turned on.

KEEP WORK AREA CLEAN.

Cluttered work areas and benches invite accidents.

DON'T USE IN DANGEROUS ENVIRONMENT.

Do not use power tools in damp or wet locations nor expose them to rain. Always keep the work area well lighted.

SAFETY:

KEEP CHILDREN AWAY.

All visitors and children should be kept a safe distance from work area.

MAKE WORKSHOP KID PROOF.

Make the workshops kid proof by using padlocks, master switches or by removing starter keys. Do not leave extension cords plugged in or easily accessible to children.

DO NOT FORCE THE TOOL.

A power tool will do a job better and safer operating at a rate for which it was designed

USE THE RIGHT TOOL.

Do not force a tool or attachment, to do a job that it was not designed to do.

USE THE PROPER EXTENSION CORD.

If using an extension cord, make sure its in good condition first. When using an extension cord, be sure to use one heavy enough to carry the current your product will draw. An undersized cord will cause a drop in line voltage that will result in a loss of power and overheating. TABLE 1, (Page 9) shows the correct AWG size to use depending on cord length and nameplate ampere rating. If in doubt, use the next heavier gage. The smaller the gage number, the heavier the cord.

WEAR PROPER APPAREL.

Do not wear loose clothing, gloves, neckties, rings, bracelets, or other jewelry that may be caught in moving parts. Nonslip footwear is recommended. Wear protective hair covering to contain long hair.

ALWAYS USE SAFETY GLASSES.



Safety glasses should always be worn when working around power tools. In addition, a face or dust mask should be worn if a cutting operation is dusty. Airborne dust particles can cause serious eye irritation and/or serious respiratory problems. Everyday eyeglasses only have impact resistant lenses and may not prevent eye injury-they are NOT safety glasses.

SECURE WORK.

Clamps or a vise should be used to hold work whenever practical. Keeping your hands free to operate a power tool is safer.

DO NOT OVERREACH.

Always keep proper footing and balance at all times by not overreaching.

MAINTAIN TOOLS WITH CARE.

Keep tools sharp and clean for the best and safest performance. Always follow maintenance instructions for lubricating and when changing accessories.

DISCONNECT TOOLS.

Power tools should always be disconnected before servicing or when changing accessories such as, blades, bits, cutters, and the like.

SAFETY:

REDUCE THE RISK OF UNINTENTIONAL STARTING.



Make sure the ON/OFF switch is in OFF position before plugging in a power tool.

USE RECOMMENDED ACCESSORIES.

Consult the owner's manual for recommended accessories. Using improper accessories may increase the risk of personal or by-stander injury.

NEVER STAND ON TOOL.

Serious injury could occur if a power tool is tipped, or, if the cutting tool is unintentionally contacted.

CHECK DAMAGED PARTS.

Before using a power tool, check for damaged parts. A guard or another part that is damaged should be carefully checked to determine it would operate properly and perform its intended function. Always check moving parts for proper alignment or binding. Check for broken parts, mountings and all other conditions that may affect the operation of the power tool. A guard, or any damaged part, should be properly repaired or replaced.

DIRECTION OF FEED.

Always feed work into a blade or cutter against the direction of rotation. A blade or cutter should always be installed such that rotation is in the direction of the arrow imprinted on the side of the blade or cutter.

NEVER LEAVE TOOL RUNNING UNATTENDED – TURN POWER OFF.

Do not leave a tool until it comes to a complete stop. Always turn a power tool OFF when leaving the work area or when finished cutting.

Hazard Symbols:

ELECTRICAL SHOCK!



Never touch electrical wires or components while the motor is running. Exposed, frayed or worn electrical motor wiring can be sources of electrical shock that could cause severe injury, burns or death.

ACCIDENTAL STARTS!



Before plugging the equipment into an electrical outlet, be sure the ON/OFF switch is in the "OFF" position to prevent accidental starting. Unplug the power tool before performing any service operation.

ROTATING OR MOVING PARTS!



Keep hands, feet, hair, and clothing away from all moving parts to prevent injury. Never operate a power tool with covers, shrouds, or guards removed.

SAFETY:

⚠ WARNING

Sawing and drilling generates dust. Airborne dust particles may cause irritation to eyes, skin and respiratory tract. To avoid breathing impairment, always employ dust controls and protection suitable to the material being sawed or drilled; See OSHA (29 CFR Part 1910.1200). Diamond Blades improperly used are dangerous. Comply with American National Standards Institute Safety Code, B7.1 and, Occupational Safety and Health Act covering Speed, Safety Guards, Flanges, Mounting Procedures, General Operating Rules, Handling, Storage and General Machine Conditions.

CALIFORNIA PROPOSITION 65 MESSAGE:

⚠ WARNING

Some dust created by power sanding, sawing, grinding, drilling, and other construction activities contain chemicals known [to the State of California] to cause cancer, birth defects or other reproductive harm. Some examples from an extensive list of potentially harmful chemicals include:

- Lead, from lead-based paints
- Crystalline silica, from bricks and cement and other masonry products and
- Arsenic and chromium, from chemically treated lumber

Your risk from these exposures varies depending on how often you do this type of work. To reduce your exposure to these chemicals, work in a well-ventilated area, and work with approved safety equipment, such as those dust masks that are specially designed to filter out microscopic particles. Such dust masks are available at most hardware stores. Carefully read the instructions that accompany the dust masks to determine appropriate use and applications.

ELECTRICAL REQUIREMENTS AND GROUNDING INSTRUCTIONS:

In order to prevent potential electrical shock and injury, the following electrical safety precautions and symbols should be followed at all times!

⚠ WARNING



In case of a malfunction or breakdown, grounding provides a path of least resistance for electric current to reduce the risk of electric shock. This tool is equipped with an electric cord having an equipment-grounding conductor and a grounding plug. The plug must be plugged into a matching outlet that is properly installed and grounded in accordance with all local codes and ordinances.

- Do not modify the plug provided – if it will not fit the outlet, have the proper outlet installed by a qualified electrician
- Improper connections of the equipment-grounding conductor can result in a risk of electric shock. The equipment-grounding conductor is the insulated conductor that has an outer surface that is green with or without yellow stripes. If repair or replacement of the electric cord or plug is necessary, do not connect the equipment-grounding conductor to a live terminal
- Do not use adaptors to bypass the 3-prong grounding plugs.
- Check with a qualified electrician or service personnel if the grounding instructions are not completely understood, or if in doubt as to whether the tool is properly grounded
- Use only 3-wire extension cords that have 3-prong grounding plugs and 3-pole receptacles that accept the tool's plug
- Repair or replace damaged or worn cord immediately

SAFETY:

⚠ WARNING



To reduce the risk of shock or electrocution, keep all connections dry and off the ground.

A Ground Fault Circuit Interrupter (GFCI) should be provided on the circuit(s) or outlet(s) to be used for the tile saw. Receptacles are available having built-in GFCI protections and may be used for this measure of safety.

When using an extension cord, the GFCI should be installed closest to the power source, followed by the extension cord and lastly, the saw.

⚠ WARNING



To avoid the possibility of the appliance plug or receptacle getting wet, position the Tile Saw to one side of a wall mounted receptacle. This will prevent water from dripping onto the receptacle or plug. A "drip loop," shown in FIGURE 2, should be arranged by the user to properly position the power cord relative to the power source.

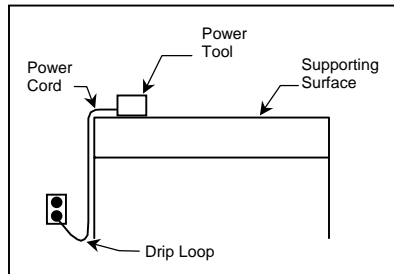

FIGURE 2

The "drip loop" is that part of the cord below the level of the receptacle, or the connector, if an extension cord is used. This method of positioning the cord prevents the travel of water along the power cord and coming in contact with the receptacle.

If the plug or receptacle gets wet, DO NOT unplug the cord. Disconnect the fuse or circuit breaker that supplies power to the tool. Then unplug and examine for presence of water in the receptacle.

⚠ WARNING

To reduce the risk of shock or electrocution, keep all connections dry and off the ground. Do not touch the plug with wet hands.

SAFETY:

⚠ WARNING



Use only extensions cords that are intended for outdoor use. These extension cords are identified by a marking "Acceptable for use with outdoor appliances; store indoors while not in use." Use only extension cords having an electrical rating not less than the rating of the product. Do not use damaged extension cords. Examine extension cords before using and replace if damaged. Do not abuse extension cords and do not yank on any cord to disconnect. Keep cords away from heat and sharp edges. Always disconnect extension cords from the receptacle before disconnecting the product form the extension cord.

⚠ WARNING



Use of undersize extension cords results in low voltage to the motor that can result in motor burnout and premature failure. MK Diamond warns that equipment returned to us showing signs of being run in a low voltage condition, with undersized extension cord, will be repaired or replaced totally at the customers expense. There will be no warranty claim.

To choose the proper extension cord,

- Locate the length of extension cord needed in TABLE 1 below.
- Once the proper length is found, move down the column to obtain the correct AWG size required for that length of extension cord.

Extension Cord Minimum Gage for Length				
Volts	Total Length of Cord in Feet			
	25 ft.	50 ft.	100 ft	150 ft.
230V	AWG	AWG	AWG	AWG
	18	16	16	14

TABLE 1

SAFETY:

LOCK OUT:

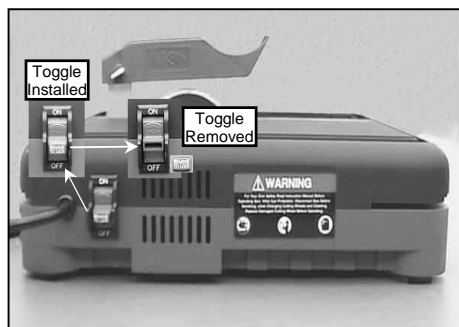

To prevent accidental starting, and to help ensure your workshop is "Kidproof," this saw is provided with a means to deactivate the functioning of the motor switch. The switch is provided with a removable toggle. With the toggle removed, the switch does not function and the motor cannot be turned on. Replacing the toggle reactivates the switch function.

SAFETY LABEL LOCATIONS:

Safety labels are located according to Figure 1 to 3 below. The labels contain important information. Please read the information contained on each label. These labels are considered a permanent part of your saw. If a label comes off or becomes hard to read, contact MK Diamond or your dealer for a replacement

Item	Location	Description	Part No.
1	Switch Side	General Safety Warnings	158315
2	Water Basin	Water level warning	N/A
3	Back	Serial Number and Motor Specifications	158316

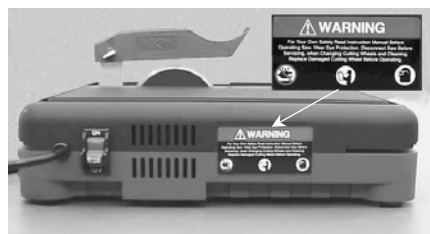

1: General Safety Warning



2: Water Level Warning

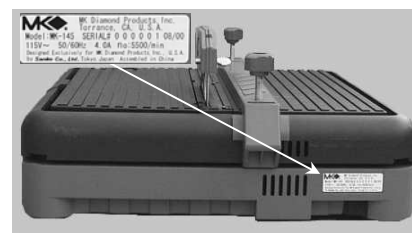

3: Serial Number and Motor Specifications

TILE SAW SPECIFIC WARNINGS:

⚠️WARNING

- Wear eye protection
- Use splash hood for every operation for which it can be used
- Disconnect saw before servicing, when changing cutting blades, and cleaning
- Use tool only with smooth edge cutting blades free of openings and grooves
- Replace damaged cutting blade before operating
- Do not fill water bath above water fill line

SAFETY:

PRODUCT SPECIFICATIONS:

The MK-145 is a versatile tabletop tile saw. Operated and used according to this manual, the MK-145 will provide years of dependable service.

General Description:

The MK-145 tile saw is engineered as a self-contained wet saw consisting of a powerful 230v motor in a hard plastic case. The saw is capable of cutting a tile up to (1) inch (25mm) thick. The water basin located below the tabletop can be filled with ordinary tap water, and is easily cleaned following use.

Motor Specifications:

Motor specifications for the MK-145 are listed in Table 2 below.

Voltage	230 v
Amperage	2 a
Frequency	50/60 Hz
RPM	5,500 rpm
Weight	11 lbs/5kgs

Table 2

Blade Capacity:

The MK-145 uses a 4-1/2 inch diameter continuous rim MK Diamond blade with a 1/16-inch cutting width. The MK 145 can miter cut at a 45-degree miter angle or a 22.5-degree angle for octagonal shapes.

Tile Types:

The MK-145 can cut a variety of tile types including Porcelain, Terracotta, Marble, Quarry and Slate, or almost any other non-ferrous material.

NOTE: The MK-145 is not designed to cut plastic or ferrous (metals) material.

UNPACKING, TRANSPORT and ASSEMBLY:

UNPACKING:

Your MK-145 has been shipped from the factory thoroughly inspected. Only minimal assembly is required.

If not done, remove the MK-145 from the box and place on a flat surface. Remove the Water Basin, Cover (See Step 1 of the Blade Guard Installation Procedure; page 13.), and remove the accessories package from the Water Basin.

CONTENTS:

In your container, you will find one (1) MK-145, one (1) 4-1/2 inch diamond blade, one (1) metal inner flange, one (1) plastic outer flange, one (1) blade nut, (1) 45° cutting guide one, (1) adjustable cutting guide, two (2), adjustable cutting guide retaining knobs, one (1) adjustable blade guard, one (1) blade guard retaining screw, one (1) MK-145 table stop, one (1) blade wrench, one (1) owners manual, and one (1) warranty card



MK-145



Diamond Blade

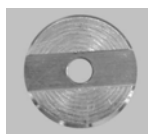

Metal Inner Flange



Plastic Outer Flange

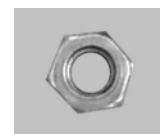

Blade Nut

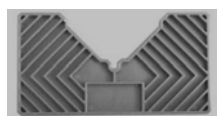

45° Cutting Guide



Adjustable Cutting Guide



Adjustable Cutting Guide Knobs



Blade Guard



Blade Guard Retaining Screw



MK-145 Table Stop



Blade Wrench



Owners Manual



Warranty Card

TRANSPORT:

The MK-145 weighs approximately eleven (11) pounds, making transport easy.

CAUTION Never transport the MK-145 with water in the Cooling Basin.



The MK-145 is designed with recessed edges in the molded plastic case for ease of transport. To transport the MK-145, simply grasp it by the two recessed edges, lift and move it to the desired location.

UNPACKING, TRANSPORT and ASSEMBLY:

ASSEMBLY:

Follow the assembly instructions to prepare your MK-145 for operation.

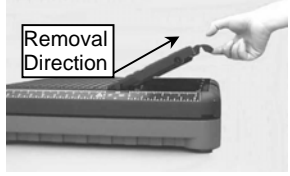
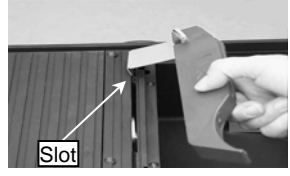
Blade Guard Installation:

STEP	ACTION	
1.	Remove Water Basin Cover a) Lift Water Basin Cover b) Pull out on Water Basing Cover to Remove	
2.	Install Diamond Blade Guard a) Insert Blade Guard into the small Slot of Cutting Table	
	a) Rotate Blade Guard Upright b) Insert Blade Guard Retaining Screw	

Diamond Blade Installation:

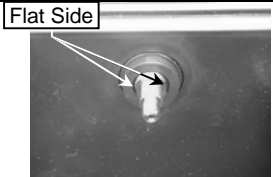
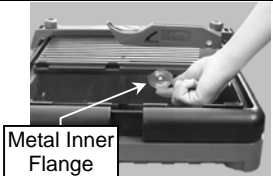
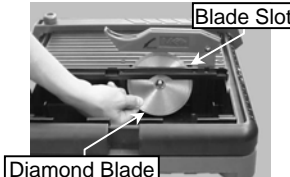
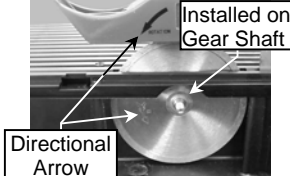
STEP	ACTION	
1.	Gear Shaft a) Locate the flat sides of the Gear Shaft	
2.	Install Metal Inner Flange a) Install the Metal Inner Flange onto the Gear Shaft b) Rotate the Metal Inner Flange until it is seated on the flat sides of the Gear Shaft	
3.	Install Diamond Blade a) Orient the Blade to the Gear Shaft with the Directional Arrow facing out b) Install the Blade through the Table Blade Slot from below	
4.	Verify Blade Seated a) Verify the Blade is seated on the Gear Shaft b) Verify Blade Directional Arrow matches the Directional Arrow on the Blade Guard	

UNPACKING, TRANSPORT and ASSEMBLY:

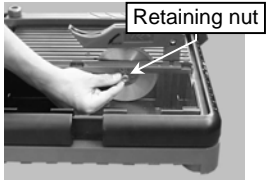
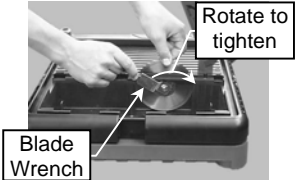
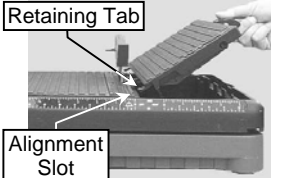
STEP	ACTION	
5.	Install Plastic Outer Flange a) Install the Plastic Outer Flange onto the Gear Shaft	
NOTE: Do not "cross-thread the Retaining Nut during installation.		
6.	Install The Retaining Nut a) Install the Retaining Nut onto the Gear Shaft – DO NOT CROSS-THREAD THE NUT	
7.	Tightening Diamond Blade a) Hold the Diamond Blade still b) Rotate the Blade Wrench clockwise to tighten – DO NOT OVER TIGHTEN	
8.	Reinstall the Water Basin Cover a) Insert the three (3) Cover Retaining Tabs into the three (3) Cover Alignment Slots b) Seat the Water Basin Cover on the MK-145	

Adjustable Cutting Guide Installation:

- NOTES: 1. The Adjustable Cutting Guide can be used on either side of the Diamond Blade.
2. Step 1 may be skipped if the Adjustable Cutting Guide is installed.

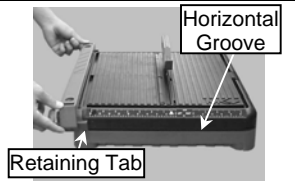
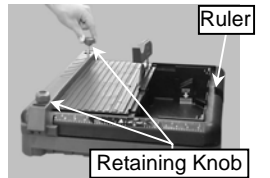
1.	Install the Adjustable Cutting Guide a) Fit the Retaining Tabs of the Adjustable Cutting Guide to the Horizontal Grooves of the MK-145 b) Slide the Adjustable Cutting Guide onto the MK-145	
2.	Retaining Knobs a) Install the two Retaining Knobs into either side of the Adjustable Cutting Guide	

UNPACKING, TRANSPORT and ASSEMBLY:

Table Stop Installation:

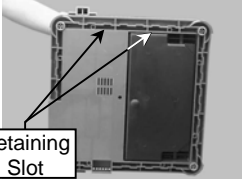
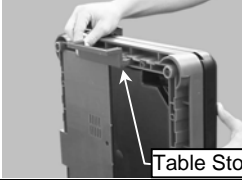
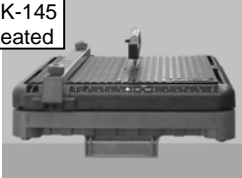
STEP	ACTION	
1.	Locate Table Stop Retaining Slots a) Rotate the MK-145 onto the back end b) Locate the Table Stop Retaining Slots	
2.	Install the Table Stop a) Install the Table stop into the MK-145 Retaining Slots	
3.	Position the MK-145 a) Place the MK-145 onto the workbench b) Position the Table Stop against the side of the work bench	

SETUP, ADJUSTMENT and OPERATION:

SETUP:

⚠ CAUTION

- Before powering or starting, check for damage, that could prevent this equipment from proper operation or performing its intended function. Check for binding and improper alignment of moving parts. Check for damaged, broken, or missing parts.
- Verify the On/Off switch is in the OFF position.
- Before connecting the MK-145 to a power supply, be sure the voltage, cycle and phase of the job site power source meet the requirements of TABLE 3

VOLTAGE:	230v
CYCLE:	50/60Hz
PHASE:	1-phase

TABLE 3

- If using an extension power cord, ensure sure the length and wire gauge correspond to the requirements listed in TABLE 1 on page 9. An extension power cord that is too small in wire gauge (diameter), or too long in length, will cause the motor to overheat and could cause premature failure.
- Use an approved Ground Fault Circuit Interrupter (GFCI)
- Do not cover the motor vents as this could lead to motor overheating.
- Do not overfill the Cooling Basin.

NOTE: In order to avoid breaker tripping, a 15-amp circuit breaker should be used.

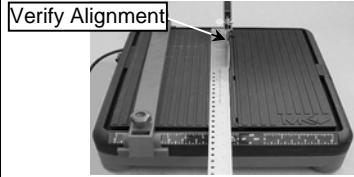
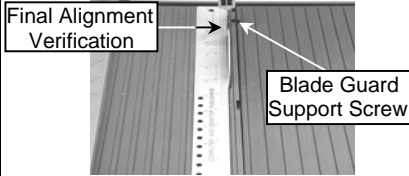
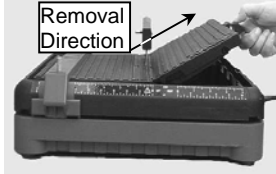
STEP	ACTION	
1.	Blade Guard Alignment Verification a) Place MK-145 on a flat, level surface b) Verify the Diamond Blade is aligned with the Blade Guard Support Angle using straight edge	
2.	Blade Guard Adjustment a) Loosen the Blade Guard Support Screw b) Align the Blade Guard to the Diamond Blade c) Retighten the Blade Guard Support Screw	
3.	Remove Water Basin Cover a) Lift Water Basin Cover b) Pull out on Water Basing Cover to remove	



SETUP, ADJUSTMENT and OPERATION:

STEP	ACTION
------	--------

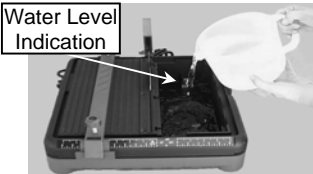
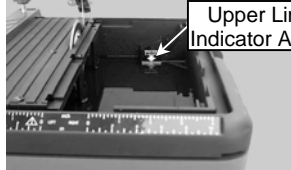
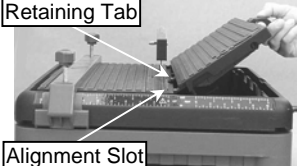
⚠ WARNING Overfilling the Water Basin can lead to water entering the motor compartment and potential electric shock.

4.	<p>Filling the Water Basin</p> <p>a) Fill the Water Basin UP TO the mark indicated on the Water Level Label</p>	 <p>Water Level Indication</p>
5.	<p>Verify Water Level</p> <p>a) Verify the Water Basin water level, is below the Upper Limit Indicator Arrow</p>	 <p>Upper Limit Indicator Arrow</p>
6.	<p>Reinstall the Water Basin Cover</p> <p>a) Insert the three (3) Cover Retaining Tabs into the three (3) Cover Alignment Slots</p> <p>b) Seat the Water Basin Cover on the MK-145</p>	 <p>Retaining Tab</p> <p>Alignment Slot</p>

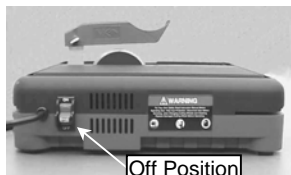

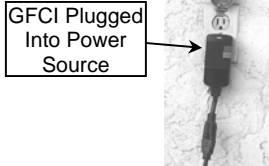
⚠ WARNING If an extension cord is used, first verify it meets the requirements of TABLE 1 (page 9). Plug the MK-145 into the extension cord, plug the extension cord into a GFCI and finally, plug the GFCI into the power source in that order.

7.	<p>Verify the ON/OFF Switch is OFF</p> <p>a) Verify the ON/OFF Switch is in the OFF position</p>	 <p>Off Position</p>
8.	<p>Plug-in the MK-145</p> <p>a) Plug the MK-145 into a GFCI</p>	 <p>GFCI</p>
	<p>b) Plug the GFCI into the power source</p>	 <p>GFCI Plugged Into Power Source</p>

SETUP, ADJUSTMENT and OPERATION:

ADJUSTMENT AND OPERATION:

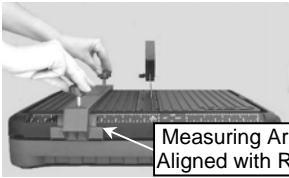
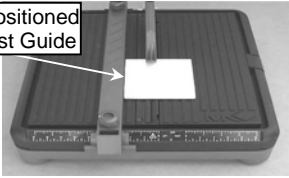
Cutting Straight Edges:

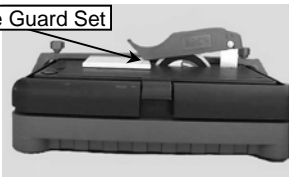
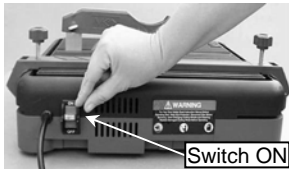

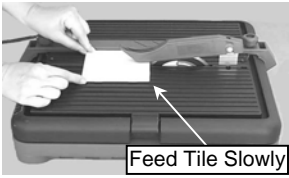
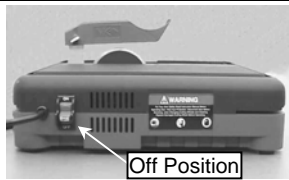

STEP	ACTION	
1.	Position Adjustable Cutting Guide a) Loosen the two (2) Retaining Knobs b) Align the Measuring Arrow of the Adjustable Cutting Guide to the cut length indicated on the Cutting Table Ruler c) Retighten the Retaining Knobs	 <p>Measuring Arrow Aligned with Ruler</p>
2.	Position the Tile a) Position the tile against the Adjustable Cutting Guide	 <p>Tile Positioned Against Guide</p>
3.	Set the Blade Guard  a) Set Blade Guard above the top of the tile	 <p>Blade Guard Set</p>
4.	Turn on the MK-145 a) Turn on the MK-145 b) Verify Cooling Water Flow around Blade Guard	 <p>Switch ON</p>

⚠ CAUTION DO NOT FORCE TOOL, it will do the job better and safer at the rate for which it was designed.

5.	Cutting Tile a) Feed the tile into the Diamond Blade with a steady even pressure (forcing the tile will cause the blade to slow which could cause motor overheating)	 <p>Feed Tile Slowly</p>
6.	Cutting Complete a) Turn saw off when cutting is complete	 <p>Off Position</p>

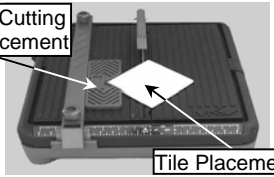
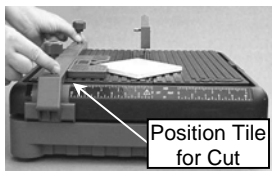
SETUP, ADJUSTMENT and OPERATION:

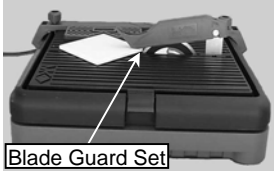
Diagonal Cutting:

STEP	ACTION	
1.	Setup Diagonal Cutting Guide a) Place the Diagonal Cutting Guide against the Adjustable Cutting Guide b) Fit the tile into the retaining slot of the Diagonal Cutting Guide	
2.	Position Adjustable Cutting Guide c) Loosen the two (2) Retaining Knobs d) Align the Adjustable Cutting Guide to the desired cut position c) Retighten the Retaining Knobs	
3.	Set the Blade Guard  a) Set Blade Guard above the top of the Tile	
4.	Turn on the MK-145 a) Turn on the MK-145 b) Verify Cooling Water Flow around Blade Guard	

⚠ CAUTION DO NOT FORCE TOOL, it will do the job better and safer at the rate for which it was designed.

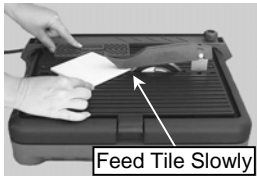
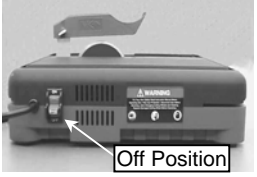

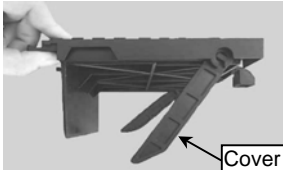
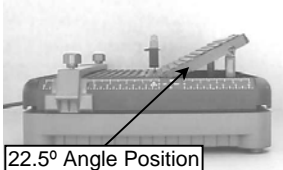
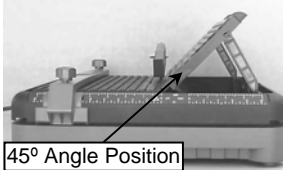

5.	Cutting Tile a) Feed the tile into the Diamond Blade with a steady even pressure (forcing the tile will cause the blade to slow which could cause motor overheating)	
6.	Cutting Complete a) Turn saw off when cutting is complete	

SETUP, ADJUSTMENT and OPERATION:

Cutting 22.5 and 45 Degree Angles:

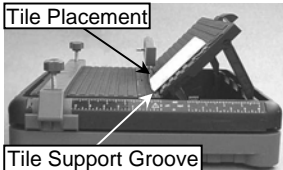
STEP	ACTION	
1.	<p>Cover Stay</p> <p>a) Pull out the two (2) Cover Stays located on the bottom of the Water Basin Cover</p>	 <p>Cover Stay</p>
2.	<p>22.5-Degree Angles</p> <p>a) Place the Cover Stays into the two (2) 22.5-degree Angle Slots (lower slots) located inside the Water Basin</p>	 <p>22.5° Angle Position</p>
3.	<p>45-Degree Angles</p> <p>a) Place the Cover Stays into the two (2) 45-degree Angle Slots (upper slots) located inside the Water Basin</p>	 <p>45° Angle Position</p>

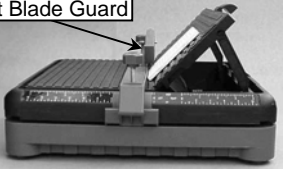
NOTE: Placing the Adjustable Cutting Guide against the edge of the tile will provide added support during the cut, and, will reduce the chance of being injured by sharp edges and chips.

4.	<p>Placing the Tile</p> <p>a) Place the tile onto the raised Cutting Table with the glazed side down</p> <p>b) Verify the tile is resting against the Tile Support Groove of the Cutting table</p>	 <p>Tile Placement</p> <p>Tile Support Groove</p>
5.	<p>Position Adjustable Cutting Guide</p> <p>a) Loosen the two (2) Retaining Knobs</p> <p>b) Position the Adjustable Cutting Guide against the edge of the tile</p> <p>a) Retighten the Retaining Knobs</p>	 <p>Position Adjustable Cutting Guide</p>
6.	<p>Set the Blade Guard</p> <p>a) Set Blade Guard above the top of the tile</p>	 <p>Set Blade Guard</p>
7.	<p>Turn on the MK-145</p> <p>c) Turn on the MK-145</p> <p>d) Verify Cooling Water Flow around Blade Guard</p>	 <p>On Position</p>

SETUP, ADJUSTMENT and OPERATION:

STEP	ACTION
------	--------

⚠ CAUTION DO NOT FORCE TOOL, it will do the job better and safer at the rate for which it was designed.

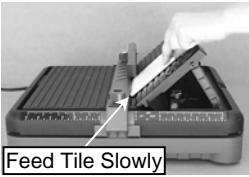
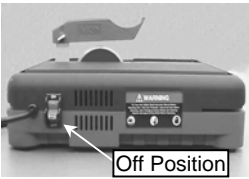
8.	<p>Cutting Tile</p> <p>a) Feed the tile into the Diamond Blade with a steady even pressure (forcing the tile will cause the blade to slow which could cause motor overheating)</p>	
9.	<p>Cutting Complete</p> <p>a) Turn saw off when cutting is complete</p>	

SETUP, ADJUSTMENT and OPERATION:

Cleanup:

STEP	ACTION
------	--------



⚠ WARNING Never empty the Cooling Basin with the ON/OFF switch in the ON position, or when power is applied.

NOTE: DO NOT use solvents or acids when cleaning the MK-145.

1.	<p>De-energize the MK-145 a) Verify the ON/OFF switch is in the OFF position</p>	
2.	<p>Un Plug the MK-145 a) Unplug the MK-145 from the power source b) Unplug the MK-145 from the GCFI</p>	
3.	<p>Remove Water Basin Cover a) Lift Water Basin Cover b) Pull out on Water Basing Cover to remove</p>	
4.	<p>Empty Water Basin a) Empty the contents of the Water Basin (Conform to Federal, State and Local laws, codes and ordinances relative to environmental protection if unsure of disposal requirements)</p>	



⚠ WARNING During the cleaning process, do not allow water to enter the motor compartment of the MK-145.



5.	<p>Cleaning a) Clean the MK-145 with clean, fresh water and dish soap b) Rinse with clean water and dry the MK-145 with a clean cloth or paper towels</p>	
----	---	--

MAINTENANCE and TROUBLESHOOTING:

MAINTENANCE:

Blade Dressing:

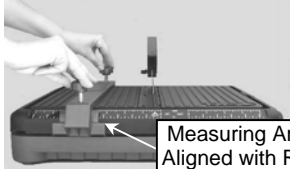
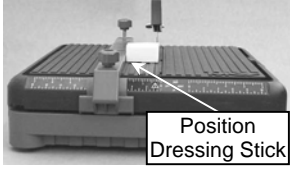
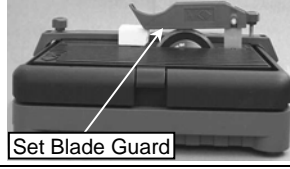
Like most cutting instruments, a diamond blade performs best when it is dressed. Over time and use, diamonds on the outer edge will become smoothed or “glazed” over. This will reduce grinding efficiency and may cause the blade to “wander” or bend giving the illusion of an alignment problem. When this occurs, the blade will need to be dressed. The diamond blade can be dressed using the MK Dressing Stick (part number 152792) and by following the steps below.

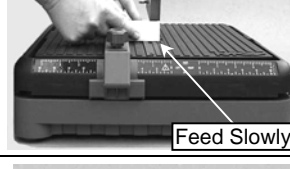
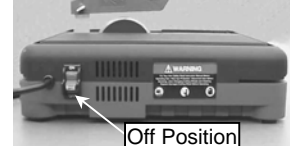
STEP	ACTION	
1.	Set Up for Operation a) Setup the MK-145 for operation (as described in the THEORY, SETUP, ADJUSTMENT AND OPERATION section)	 Set Up for Operation
2.	Position Adjustable Cutting Guide a) Loosen the two (2) Retaining Knobs b) Position the Adjustable Cutting Guide to cut a length of 1/16-inch c) Retighten the Retaining Knobs	 Measuring Arrow Aligned with Ruler
3.	Set Dressing Stick a) Place the Dressing Stick on the Cutting Table against the Adjustable Cutting Guide	 Position Dressing Stick
4.	Set the Blade Guard a) Set Blade Guard above the top of the Dressing Stick	 Set Blade Guard
5.	Turn on the MK-145 a) Turn on the MK-145 b) Verify Cooling Water Flow around Blade Guard	 On Position
6.	Sharpening the Blade a) Feed the Dressing Stick into the Diamond Blade with a steady even pressure (forcing the tile will cause the blade to slow which could cause motor overheating)	 Feed Slowly
7.	Cutting Complete a) Turn saw off when cutting is complete	 Off Position

MAINTENANCE and TROUBLESHOOTING:

Diamond Blade Change-out:

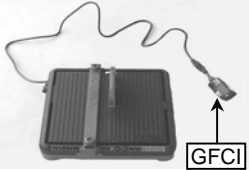
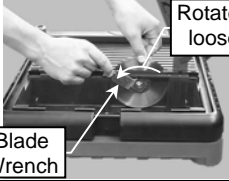
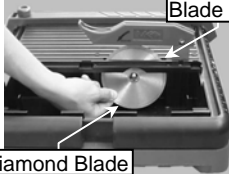
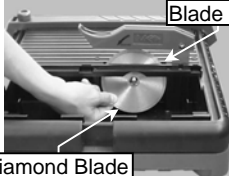
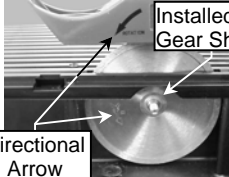
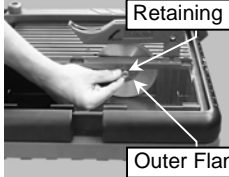
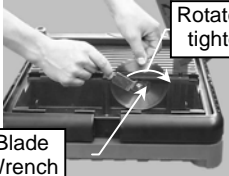
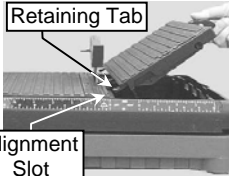



STEP	ACTION	
1.	Unplug the MK-145 a) Unplug the MK-145 from the power source b) Unplug the MK-145 from the GCFI	
2.	Remove Retaining Nut and Outer Flange a) Hold the Diamond Blade still b) Rotate the Blade Wrench counter-clockwise to loosen c) Remove the Retaining Nut and Outer Flange	
3.	Remove the Diamond Blade a) Remove the Blade out from between the Table Blade Slot from below	
4.	Install Diamond Blade a) Orient the Blade to the Gear Shaft with the Directional Arrow facing out b) Install the Blade through the Table Blade Slot from below	
5.	Verify Blade Seated a) Verify the Blade is seated on the Gear Shaft b) Verify Blade Directional Arrow matches the Directional Arrow on the Blade Guard	
NOTE: Do not “cross-thread the Retaining Nut during installation.		
6.	Install The Retaining Nut and Outer Flange a) Install the Plastic Outer Flange onto the Gear Shaft b) Install the Retaining Nut onto the Gear Shaft	
7.	Tightening Diamond Blade a) Hold the Diamond Blade still b) Rotate the Blade Wrench clockwise to tighten – DO NOT OVER TIGHTEN	
8.	Reinstall the Water Basin Cover a) Insert the three (3) Cover Retaining Tabs into the three (3) Cover Alignment Slots b) Seat the Water Basin Cover on the MK-145	

MAINTENANCE and TROUBLESHOOTING:

TRUBLESHOOTING:

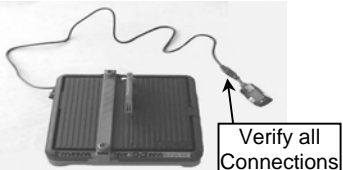
⚠️WARNING Turn the ON/OFF switch to the OFF position and unplug the saw from the power source before performing any troubleshooting procedure.

Motor Stops Turning:

STEP	ACTION	
1.	Verify Plugs Fully Connected <ul style="list-style-type: none"> • If not fully connected, reconnect plugs and turn on the saw • If fully connected, go to step 2 	
2.	Check Ground Fault Circuit Interrupter (GFCI) <ul style="list-style-type: none"> • If the GFCI is tripped reset it and turn on the saw • If the GFCI is not tripped, go to step 3 	
3.	Verify Circuit Breaker at least 15 Amps <ul style="list-style-type: none"> • If the circuit breaker is not 15 amps, move the saw to a 15-amp circuit breaker and turn on saw • If the circuit breaker is 15 amps, go to step 4 	
4.	Verify Circuit Breaker Not Tripped <ul style="list-style-type: none"> • If tripped, reset the breaker once and turn on the saw • If the saw trips again, proceed to step 6 • If the circuit breaker is not tripped, go to step 5 	
5.	Check Power Source Voltage is 230 volts <ul style="list-style-type: none"> • If power source is not at 230v move the saw to another circuit and turn on the saw • If the power source is at 230v, go to step 6 	
7.	Return the MK-145 for Repair <ul style="list-style-type: none"> • Return the MK-145 for repair per the Return Instructions section of this procedure 	<div style="border: 1px solid black; padding: 10px; text-align: center;"> <p>Return to MK Diamond for Repair</p> </div>

MAINTENANCE and TROUBLESHOOTING:

Blade Will Not Cut Properly:

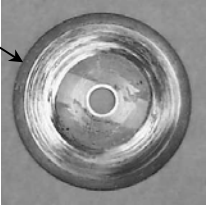
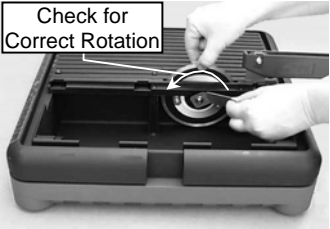
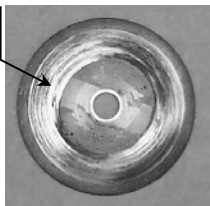
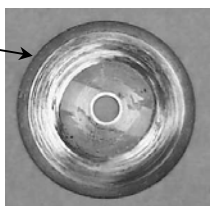
STEP	ACTION	
1	<p>Check Blade for Smoothness ("Glazing")</p> <ul style="list-style-type: none"> • If blade is smooth, sharpen per Blade Sharpening Section of this manual • If blade is not glazed, go to step 2 	<p>Check for Glazing</p> 
2.	<p>Check Blade Rotation</p> <p>Verify blade rotates in counter-clockwise direction as indicated by arrow on the diamond blade.</p> <ul style="list-style-type: none"> • If not rotating correctly, reposition the blade to correct position • If rotating correctly, go to step 3 	<p>Check for Correct Rotation</p> 
3.	<p>Ensure Blade Core Not Bent</p> <ul style="list-style-type: none"> • If the blade core is bent, replace blade per the Diamond Blade Change-out procedure of this manual • If the blade core is not bent, go to step 4 	<p>Check for Bent or Damaged Core</p> 
4.	<p>Check Blade is Correct for Material Being Cut</p> <p>Contacting place of purchase or MK Diamond at – 800-421-5830 to verify blade</p> <ul style="list-style-type: none"> • If the blade is not correct, obtain the correct blade • If the blade is correct, go to step 5 	<p>Check Correct Blade is Being Used</p> 
5.	<p>Return the MK-145 for Repair</p> <ul style="list-style-type: none"> • Return the MK-145 for repair per the Return Instructions section of this procedure 	<p>Return to MK Diamond for Repair</p>

EXPLODED VIEW and PARTS LIST:

EXPLODED VIEW:

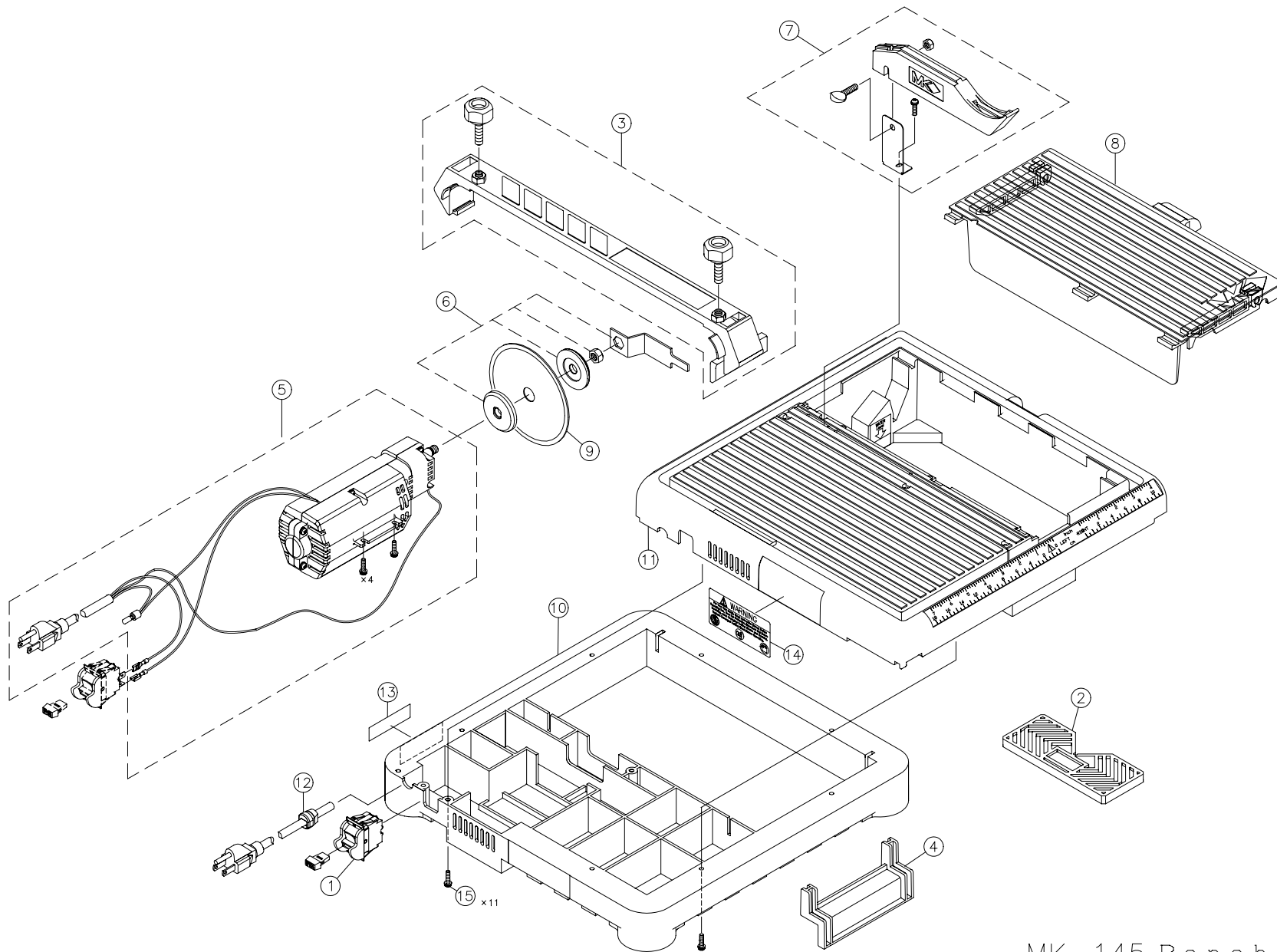

MK-145 Bench

EXPLODED VIEW and PARTS LIST:**PARTS LIST:**

Number	Kit Name	MK Diamond Part Number
1	Switch	158303
2	Diagonal Cutting Guide	158304
3	Adjustable Cutting Guide	158305
4	Table Stop	158306
5	Motor Assembly	158307
6	Flange Assembly	158308
7	Blade Guard Assembly	158309
8	Cutting Table Cover Assembly	158310
9	Diamond Blade	158311
10	MK-145 Molded Base	158312
11	MK-145 Molded Top	158313
12	Power Cord	158314
13	Warning Label	158315
14	Nameplate Label	158316
15	Mounting Screws (Top to Base)	158317

THEORY:

THEORY OF DIAMOND BLADES:

Diamond blades do not really cut; they grind the material through friction. Diamond crystals, often visible at the leading edge and sides of the rim/segment, remove material by scratching out particles of hard, dense materials, or by knocking out larger particles of loosely bonded abrasive material. This process eventually cracks or fractures the diamond particle, breaking it down into smaller pieces. As a result, a diamond blade for cutting soft, abrasive material must have a hard metal matrix composition to resist this erosion long enough for the exposed diamonds to be properly utilized. Conversely, a blade for cutting a hard, non-abrasive material must have a soft bond to ensure that it will erode and expose the diamonds embedded in the matrix. These simple principles are the foundation of “controlled bond erosion”.



Types of Cutting:

There are two basic types of cutting, Dry, or Wet. The choice of which type of blade to use depends on:

- The requirements of the job
- The machine/tool utilizing the diamond blade
- The preference of the operator





In the case of DRY cutting, the overwhelming popularity and quantity of hand-held saws and the flexible nature of MK Diamond blades to professionally handle most ceramic, masonry, stone and concrete materials, make the DRY cutting blade a very attractive tool. When using a DRY blade, the user must be aware of distinct operating practices to ensure optimum performance. DRY cutting blades require sufficient airflow about the blade to prevent overheating of the steel core. This is best accomplished by shallow, intermittent cuts of the material with periods of “free-spinning” (for several seconds) between each cut, to maximize the cooling process.

For WET cutting applications, MK has the exact blade to compliment both the material to be cut and the wet cutting machine to be used. During cutting operations, liberal amounts of water act as a coolant to support the cutting effectiveness and longevity of the WET blade. Additionally, using water adds to the overall safety of cutting operations by keeping the dust signature down.

Know All You Can About the Material You Wish to Cut

ACCESSORIES, ORDERING and RETURN INSTRUCTIONS:

ACCESSORIES:

ITEM	NUMBER	DESCRIPTION	
1.	158309	Blade Guard Assembly	
2.	158304	Diagonal Cutting Guide	
3.	158305	Adjustable Cutting Guide	
4.	158311	Diamond Blade	
5.	152610	Ground Fault Circuit Interrupter (Not Included with the MK-145)	

ACCESSORIES, ORDERING and RETURN INSTRUCTIONS:

ORDERING INFORMATION:

You may order MK Diamond products through your local MK Diamond distributor or, you may order direct from MK Diamond.

NOTE: There is a \$25.00 minimum order when ordering direct from MK Diamond. All purchases must be made using VISA or MasterCard.

When ordering direct from MK Diamond, please provide the following information:

- The Model Number of the saw
- The Serial Number of the saw
- Where the saw was purchased
- When the saw was purchased
- The Part Number for the part(s) being ordered
- The Part Description for the part(s) being ordered

All parts may be ordered by calling toll free to – **800 421-5830** or **310 539-5221** and asking for Customer Service. For technical questions, call – **800 474-5594**.

RETURN MATERIALS POLICY:

To expedite the service relative to the return of a product purchased through MK Diamond, please observe the following:

NOTE: All when returning items, they must have been purchased within the previous twelve (12) months.

- Have the Model Number of the saw
- Have the Serial Number of the saw
- Have the location of where the saw was purchased
- Have the date when the saw was purchased
- Contact Customer Service for approval to return the item(s)
- Obtain a Returned Authorization Number (RAN) authorizing the return
- Follow the packaging instructions in the following section
- Ensure your item(s) are prepaid to the destination

PACKAGING INSTRUCTIONS:

- Remove the Blade Guard and Support Angle Assembly
- Dry the saw before shipping
- When packing, include the following: MK-145, Diamond Blade, Blade Guard and Support Angle Assembly and Adjustable Cutting Guide (Other Accessories are not required)
- Package the unit in its original container or one of comparable size (do not ship the unit partially exposed)
- Ensure all parts are secured in the packaging to prevent moving

AUTHORIZED SERVICE CENTERS:

For quicker repair time, you may contact MK Diamond Customer Service, toll free, at – **800 421-5830** or **310 539-5221** for the Authorized Service Center closest to you. For technical questions, call – **800 474-5594**.

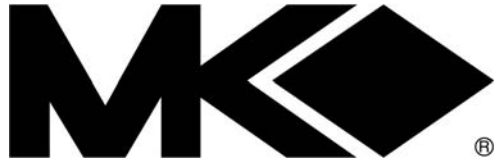

MK-145 SERIES

TILE SAW OWNER'S MANUAL & OPERATING INSTRUCTIONS

CALIFORNIA PROPOSITION 65 MESSAGE:

⚠ WARNING

Some dust created by power sanding, sawing, grinding, drilling, and other construction activities contain chemicals known [to the State of California] to cause cancer, birth defects or other reproductive harm. Some examples from an extensive list of potentially harmful chemicals include:

- Lead, from lead-based paints
- Crystalline silica, from bricks and cement and other masonry products and
- Arsenic and chromium, from chemically treated lumber

Your risk from these exposures varies depending on how often you do this type of work. To reduce your exposure to these chemicals, work in a well-ventilated area, and work with approved safety equipment, such as those dust masks that are specially designed to filter out microscopic particles. Such dust masks are available at most hardware stores. Carefully read the instructions that accompany the dust masks to determine appropriate use and applications.

MK DIAMOND PRODUCTS, INC
1315 STORM PARKWAY, TORRANCE, CA 90509-2803
310 539 5158