

MK-101 TILE SAW

PARTS LIST



MK-101 Part # 167979
Part # 151991-SP

Revision 116	08.2018
Manual Part No. 168237	

Caution: Read all safety and operating instructions before using this equipment. This manual **MUST** accompany the equipment at all times.

MK-101 Saw Part #167979

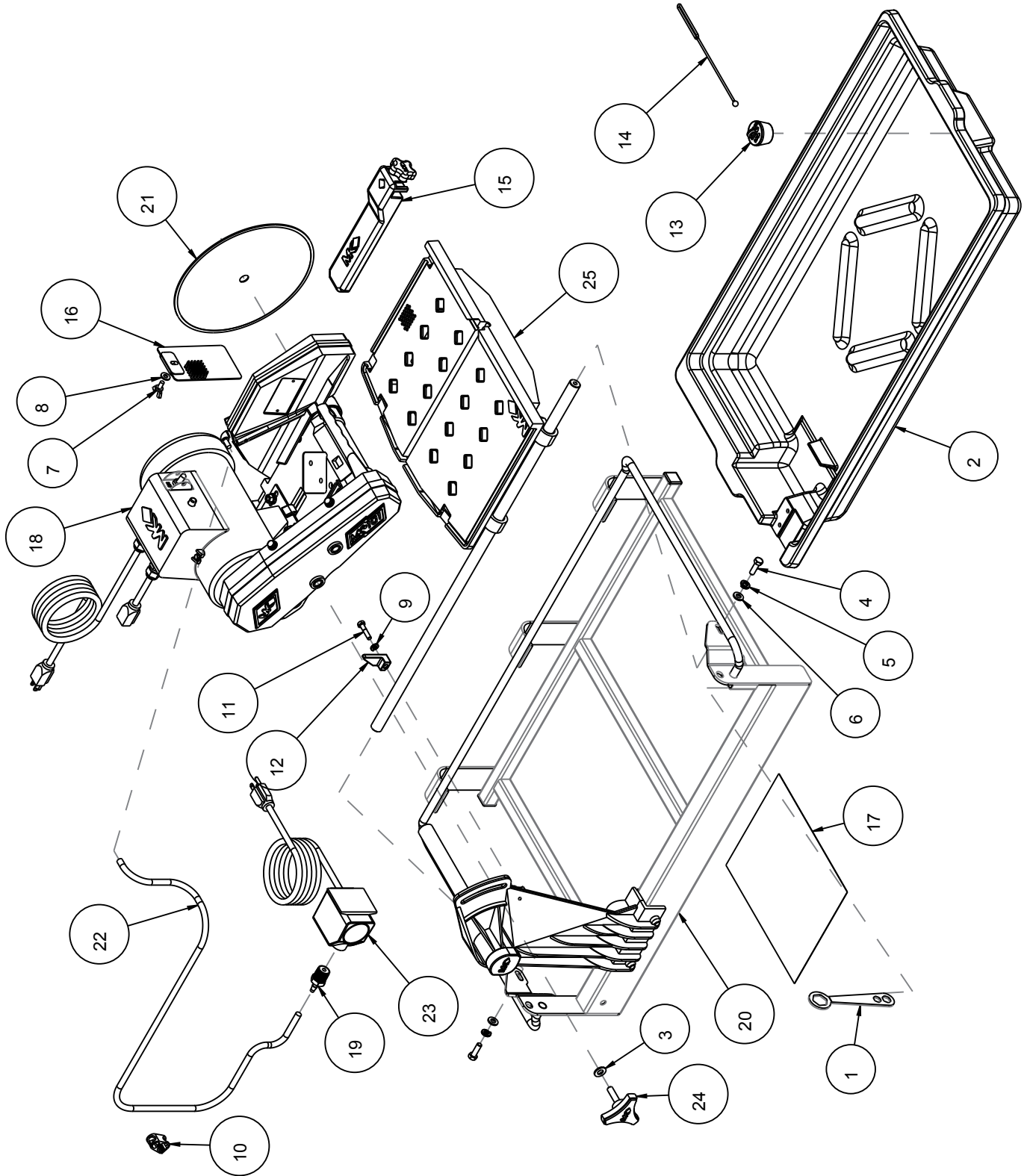

MK-101 Saw Part #167979

Item	Description	Part #	Qty
1	WRENCH, TILE SAW NUT 15/15	134684	1
2	PAN, PLASTIC MK-101	150634	1
3	WASHER, FLAT, SAE, 3/8	150923	1
4	SCREW, HEX HD, 5/16 - 18 X 1	151743	2
5	WASHER, LOCK, SPLIT, 15/16	151747	2
6	WASHER, FLAT, SAE, 5/16	151754	2
7	SCREW, WING, 1/4 - 20 X 1/2	151888	1
8	WASHER, FLAT, SAE, 1/4	152591	1
9	WASHER, LOCK, SPLIT 1/4	151915	1
10	CLAMP, HOSE, 1/4 - 1/2 FLOW	154394	1
11	SCREW, HEX HD 1/4 - 20 X 1-1/4	157145	1
12	STOP, CUTTING HEAD	157728	1
13	DRAIN PLUG, W/RING	159529	1
14	STRAP, 9" DRAIN PLUG	159530	1
15	RIP GUIDE, LARGE DIE CAST	159751	1
16	GUARD, SPLASH	160310	1
17	SHEET, WARNING LABELS, TILE SAW	166012	1
18	ASSY, CUTTING HEAD, MK-101	168167	1
19	ADAPTER, 1/2 NPT X 1/4 BARB	168261	1
20	ASSY, FRAME & POST, MK-101	170476	1
21	10" PREMIUM PORCELAIN TILE BLADE	170588	1
22	HOSE, VINYL, 1/4 X 3/8 (6.0')	132951	1
23	PUMP, WATER 115V/60HZ UL/CSA	151271-VP	1
24	KNOB, TRI PLASTIC MK-660 1 - 1/2	156770-02	1
25	ASSY, DC TABLE, NO COVER, 101	158477-NC	1

Frame Assembly
Part# 170476

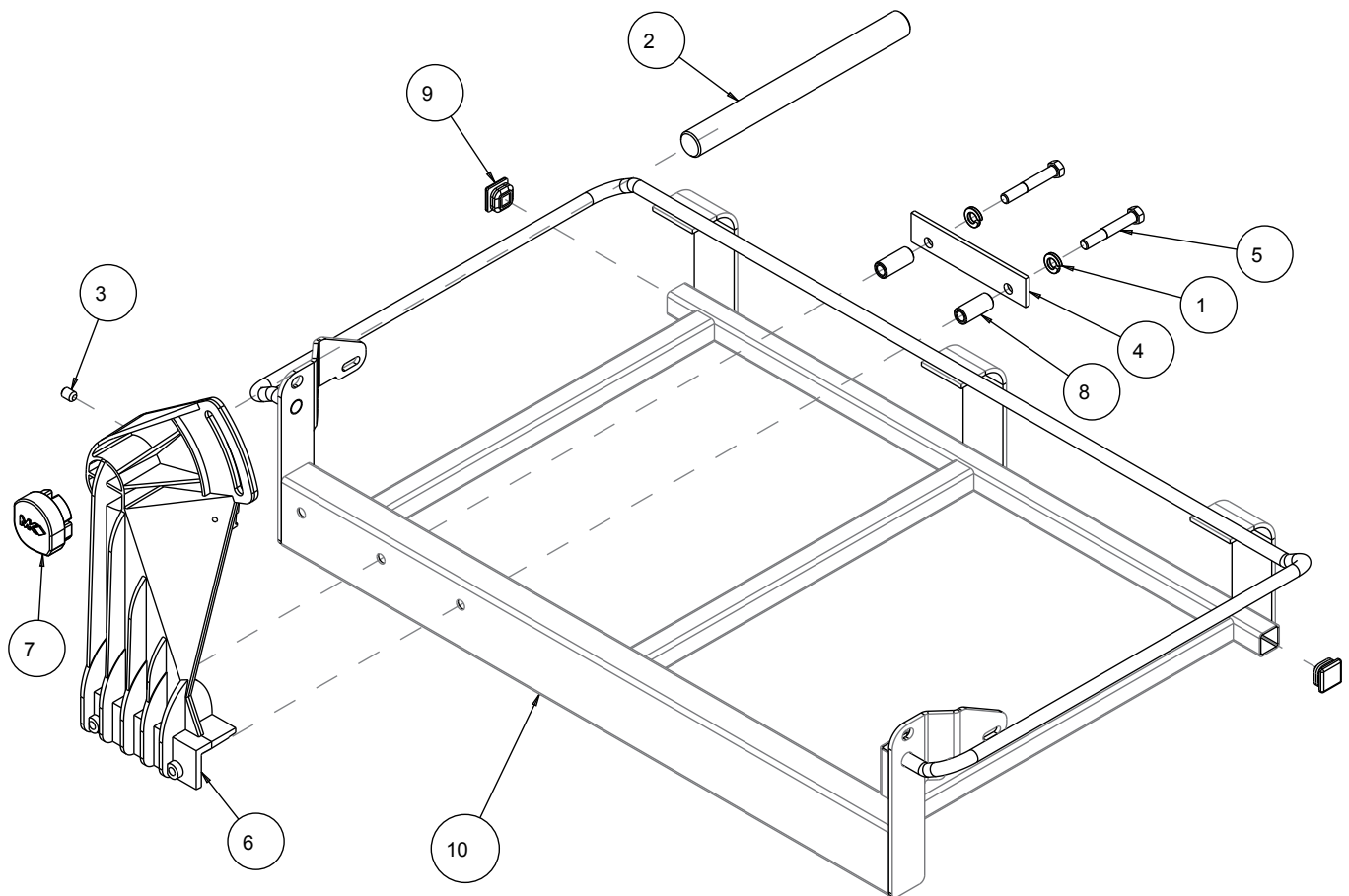

Item	Description	Part #	Qty
1	WASHER, LOCK, SPLIT, 3/8	150925	2
2	SHAFT, 10.63 PIVOT	153254	1
3	SCREW, SET, SOC, CUPT, 3/8 - 16 X 1/2	153710	1
4	PLATE, PRESSURE	155671	1
5	SCREW, 3/8 16 X 2-1.2 HEX HEAD CAP	156030	2
6	CASTING, POST, DC, 101 MKRED-COMP	158438	1
7	POST COVER, PLASTIC	160157	1
8	SPACER, 5/8 X .385 X 1/4	160654	2
9	PLUG, PLASTIC, 1 SQ - 14 - 20 GA	160727-1	2
10	FRAME, 10" TILE SAW, 18" RIP	168021	1

Table Assembly
Part# 158477-NC

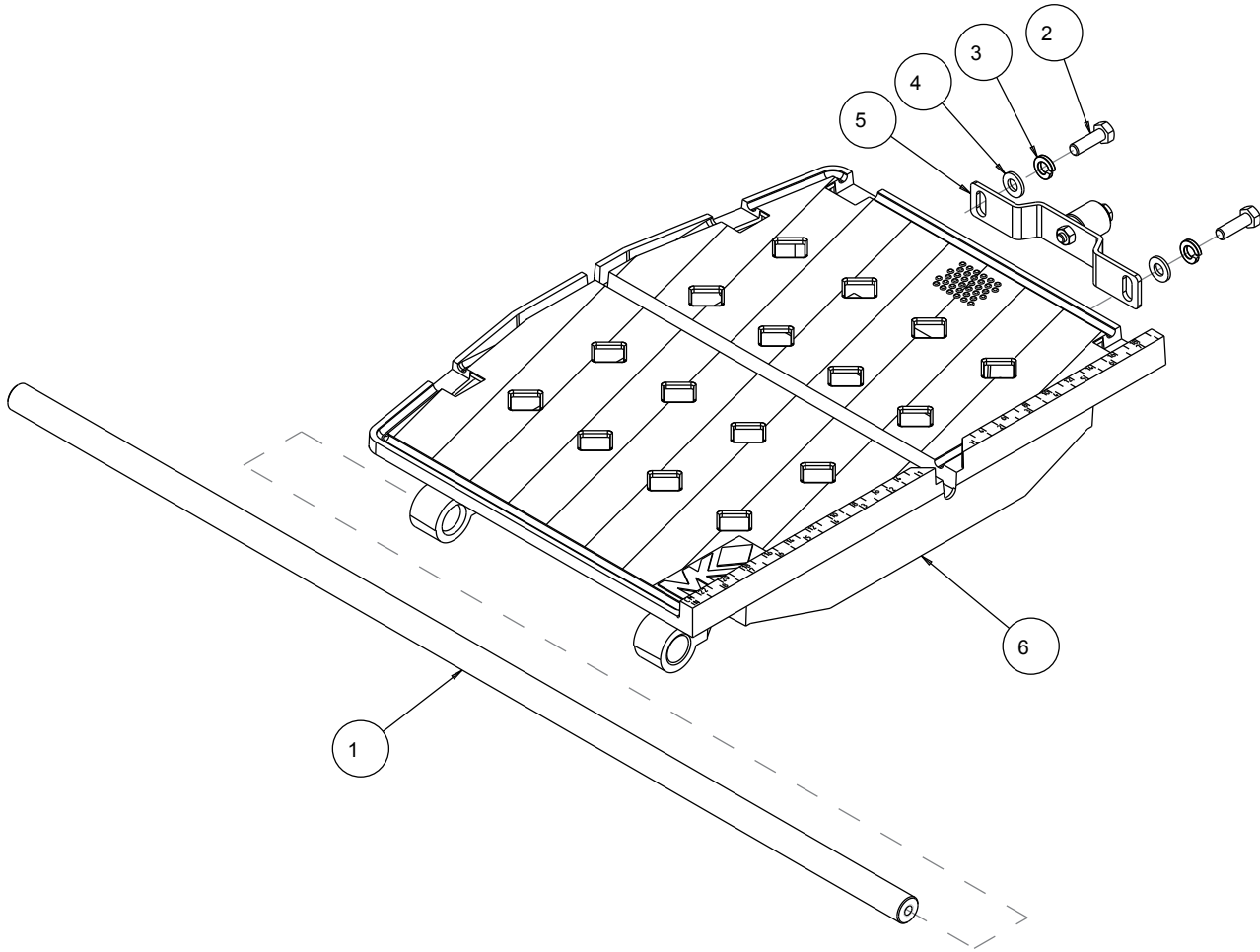

Item	Description	Part #	Qty
1	BAR, GUIDE PLATED MK-101	134759	1
2	SCREW, HEX HD, 5/16 - 18 X 1	151743	2
3	WASHER, LOCK, SPLIT, 5/16	151747	2
4	WASHER, FLAT, SAE, 5/16	151754	2
5	ASSY, WHEEL BRKT TSAW	151756	1
6	CASTING, TABLE MK-100 COMP	157660	1

Cutting Head Assembly
Part# 168167

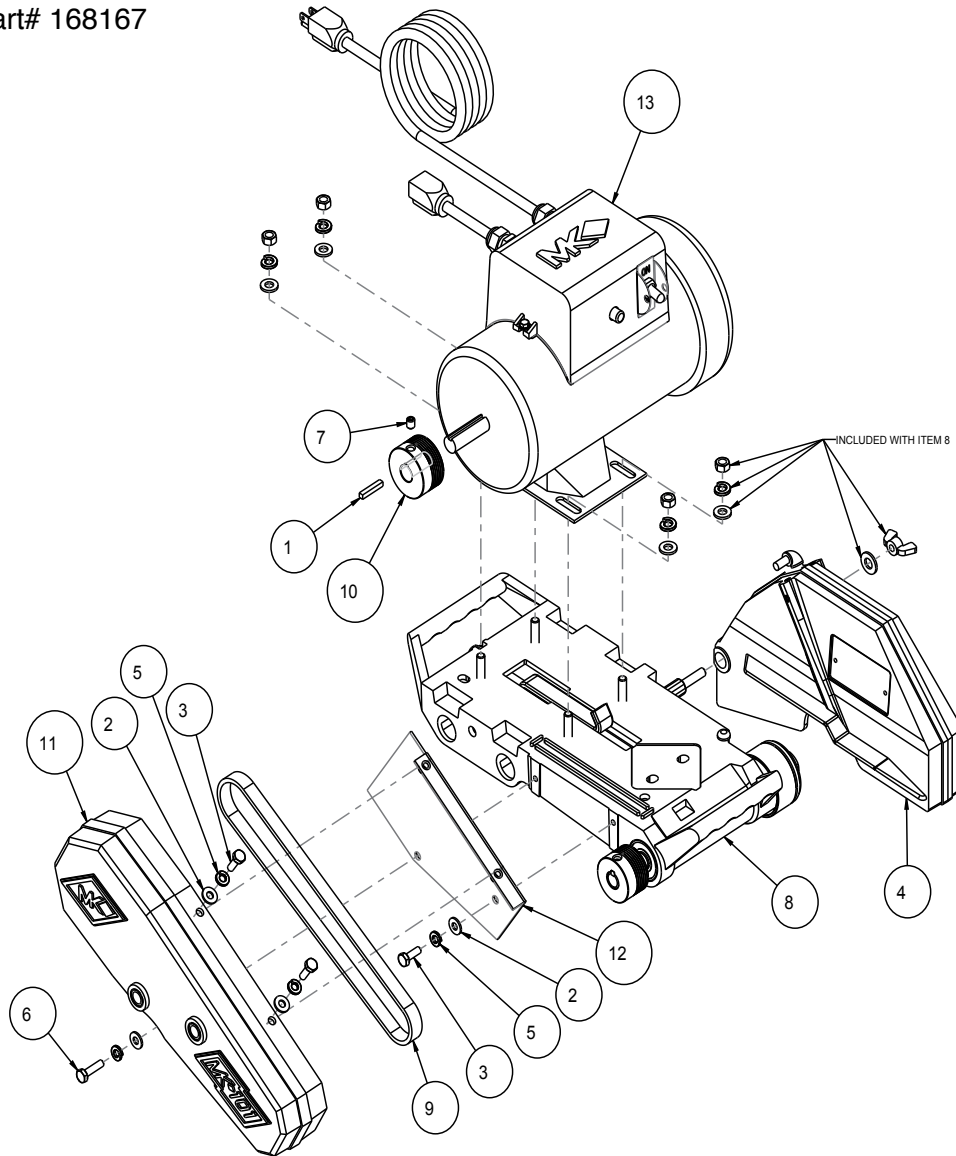

Item	Description	Part #	Qty
1	KEY, 3/16 SQ X 1-1/8	150344	1
2	WASHER, 1/4 SAE FLAT	151915	4
3	SCREW, HEX HD, 1/4 -20 X 3/4	152370	3
4	ASSY, BLADE GUARD, 101	152582	1
5	WASHER, 1/4 SPLIT LOCK	152591	4
6	SCREW, HEX HD TAP, 1/4 - 20 X 1	152676	1
7	SCREW, 5/16 -18 X 3/8 SOCKET HEAD SET	157083	1
8	ASSY, SBU, CUTTING HEAD MK-101	158191	1
9	BELT, 6J260	158194	1
10	PULLEY, 6J19 X 5/8 BORE	158199	1
11	CASTING, 101 BELT GUARD-COMP	158319-01	1
12	BRACKET, INNER BELTGUARD	158611	1
13	MTR, 1-1/2 HP, 115V, 3400 RPM	168022	1

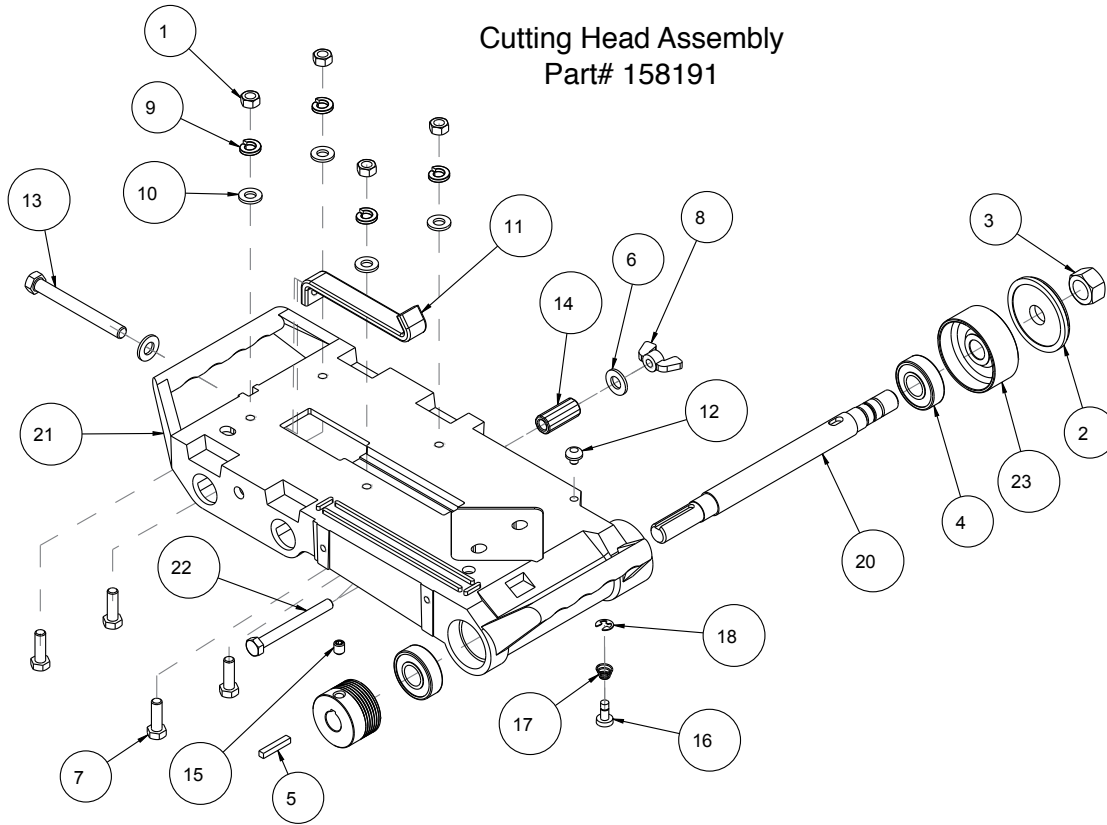

ITEM #	DESCRIPTION	PART #	QTY.
1	NUT, HEX, 5/16 - 18	101196	5
2	FLANGE, OUTER, 2 - 3/8	135830	1
3	NUT, HEX, 5/8-18	135848	1
4	BEARING, BALL, 17X40X12MM	137711	2
5	KEY, 3/16 SQ X 1-1/8	150344	1
6	WASHER, FLAT, SAE, 3/8	150923	1
7	SCREW, HEX HD, 5/16-18X1	151743	4
8	NUT, WING, NYLK, 5/16-18	151746	1
9	WASHER, LOCK, SPLIT, 5/16	151747	4
10	WASHER, FLAT, SAE, 5/16	151754	5
11	STRAP, 1 INCH, MOTOR ADJ.	152673	1
12	BUMPER, RUBBER, 1/2 DIA	152674	1
13	BOLT, 3/8-16 X 3-1/2 HEX HEAD TAP	153147	1
14	SCREW, 5/16-18 X 3/8 SOCKET HEAD SET	157083	1
15	PULLEY, 6J19 X 5/8 BORE	158199	1
16	BUTTON, SHAFT LOCK	158200	1
17	SPRING, BLADE SHAFT LOCK	158201	1
18	RING, 1/4 E-STYLE RETAINING	158202	1
19	SHAFT, BLADE	158222	1
20	CASTING, 10" CTTG HEAD - COMP	158224	1
21	SCREW, HEX HD, TAP, 5/16-18X3	162473	1
22	FLANGE, Ø 2-3/8 INNER	162758	1
23	SPACER, 9/16X5/16X1.5, PLAS	170824	1

Blade Guard Assembly
Part# 152582

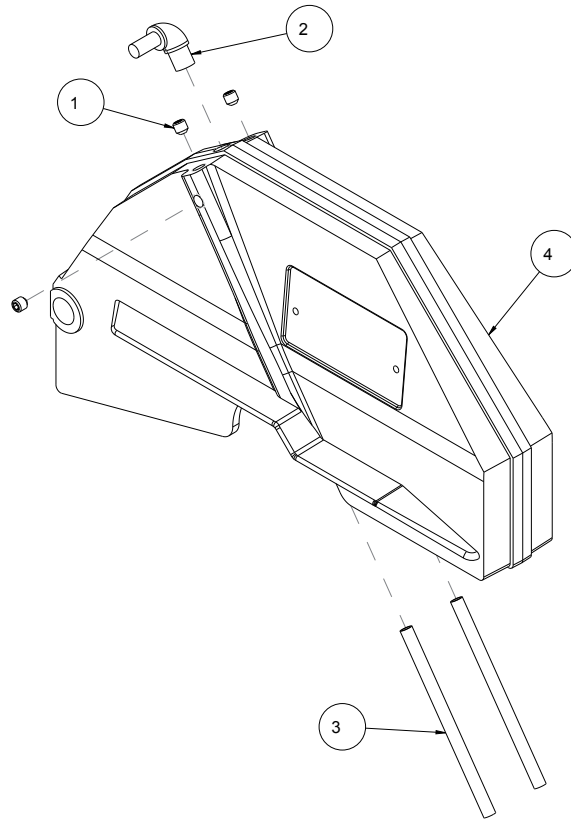

Roller Wheel Assembly
Part# 151756

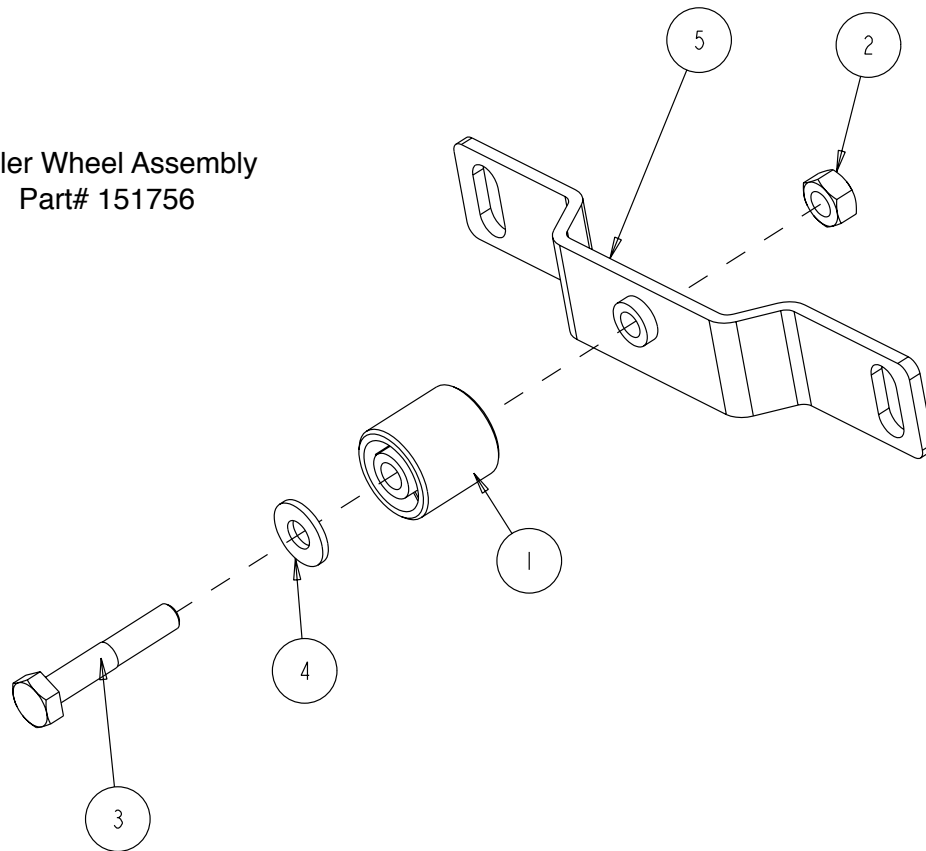

Blade Guard Assembly Part# 152582

Item	Description	Part #	Qty
1	SCREW, 5/16 - 18 X 1/2 SOCKET HD SET	152607	3
2	ELBOW, 1/8MNPT X 1/4 BARB, 90 DEG	154652	1
3	TUBE, WATER	155389	2
4	CASTING, 101 BLD GUARD-DC-COMP	162481	1

Roller Wheel Assembly Part# 151756

Item	Description	Part #	Qty
1	WHEEL, ROLLER	151799	1
2	NUT, HEX, 1/4 - 20	151893	1
3	SCREW, HEX HEAD 1/4 -20 X 1-1/2"	151914	1
4	WASHER, 1/4 SAE FLAT	151915	1
5	BRACKET, ROLLER WHEEL	154021	1

ITEM	NUMBER	DESCRIPTION	
1.	137166	MK-200, 10 x 5/8 Arbor Premium grade Diamond Blade for smooth, chip-free cutting on tile.	
2.	128074	MK-215, 10 x 5/8 Arbor Supreme grade diamond blade for hard materials	
3.	153252	MK-315, 10 x 5/8 Arbor Supreme super hi-rim diamond blade	
4.	134577-MK	Dual 45° Flat Angle Guide	
5.	153201-MK (large)	45° Bullnose Miter	
6.	152792	Dressing Stone	
7.	152610	Ground Fault Circuit Interrupter	
8.	168244	Folding Stand for 10" Tile Saw	
9.	169243	Rolling Folding Stand	

ORDERING INFORMATION

You may order MK Diamond products through your local MK Diamond distributor or, you may order direct from MK Diamond.

When ordering direct from MK Diamond, please have the following information ready before calling:

- The Model Number of the saw
- The Serial Number of the saw
- Where the saw was purchased and when
- The Part Number for the part(s) being ordered
- The Part Description for the part(s) being ordered

NOTE: Standard orders are \$50.00 or more when ordering direct from MK Diamond. A \$6.00 charge will be added to orders having a net billing value under \$50.00. A nominal handling fee of \$5.00 may apply to some orders.

All parts may be ordered by calling toll free to – 800 421-5830 or 310 539-5221 and asking for Customer Service. For technical questions, call – 800 474-5594.

RETURN MATERIALS POLICY

To expedite the service relative to the return of a product purchased through MK Diamond, please observe the following:

NOTE: When returning all items, they must have been purchased within the previous twelve (12) months.

- Have the Model Number of the saw
- Have the Serial Number of the saw
- Have the location of where the saw was purchased
- Have the date when the saw was purchased
- Contact Customer Service for approval to return the item(s)
- Obtain a Returned Goods Number (RGA) authorizing the return
- Follow the packaging instructions in the following section
- Ensure the RGA number is on the outside of the returned package
- Ensure your item(s) are prepaid to the destination

For returned items, call toll free to – 800 421-5830 or 310 539-5221 and ask for Customer Service.

PACKAGING INSTRUCTIONS

- Remove the Cutting Head and Support Angle Assembly
- Dry the saw before shipping
- When packing, include the following: Saw, Diamond Blade, Blade Guard and Support Angle Assembly and Adjustable Cutting Guide (Other Accessories are not required)
- Package the unit in its original container or one of comparable size (do not ship the unit partially exposed)
- Ensure all parts are secured in the packaging to prevent moving

AUTHORIZED SERVICE CENTERS

For quicker repair time, you may contact MK Diamond Customer Service, toll free, at 800 421-5830 or 310 539-5221 for the Authorized Service Center closest to you or visit our web site at www.mkdiamond.com. For technical questions, call – 800 474-5594.

CONTACT

Please contact MK Diamond Products, Inc. Customer Service Department with any questions you might have regarding distributors, parts or service.

Telephone: **(800) 421-5830**

Fax: **(310) 539-5158**

E-mail: **Customer_Service@MKDiamond.com**

Customer Service Hours: **Monday through Friday, 6AM-4PM PST**

MK Diamond Products, Inc.

1315 Storm Parkway

Torrance, CA 90501

MK DIAMOND PRODUCTS, INC. LIMITED WARRANTY

MK DIAMOND PRODUCTS, INC. will guarantee every machine they build, to be free from defects in material and workmanship for (1) one year from date of purchase. The obligation of MK DIAMOND PRODUCTS, INC. under this warranty is limited to the repair or replacement of any parts which, under normal use, prove to be defective in material or workmanship. The parts involved or the unit in question should be returned to MK DIAMOND PRODUCTS, INC. or to a point designated by us, transportation prepaid.

This warranty does not obligate us to bear the cost of labor or transportation charges in connection with replacement or repair of defective parts. Likewise, it shall NOT apply to any unit which has been subjected to misuse, neglect or accident. This warranty does NOT apply to any machine which has been repaired or altered outside our factory.

This warranty does NOT obligate MK DIAMOND PRODUCTS, INC., with respect to items not of our manufacture, such as engines, motors, hydraulics, etc., which are subject to their own guarantees and warranties.

We shall in no event be liable for consequential damages or contingent liabilities arising out of failure of any equipment or parts to operate properly.

© COPYRIGHT 2018, MK DIAMOND PRODUCTS, INC. ALL RIGHTS RESERVED.

The MK Diamond logo is a registered trademark of MK Diamond Products, Inc. and may not be used, reproduced, or altered without written permission. All other trademarks are the property of their respective owners and used with permission.

MK Diamond may have patents, patent applications, trade marks, copyrights of other intellectual property right covering this product in this document.

This manual MUST accompany the equipment at all times. This manual is considered a permanent part of the equipment and should remain with the unit if resold.

The information and specifications included in this publication were in effect at the time of approval for printing.



MK Diamond Products, Inc.

MK Diamond Products, Inc.
1315 Storm Parkway
Torrance, CA 90501

Toll-Free: (800) 421-5830
Phone: (310) 539-5221
Fax: (310) 539-5158
www.mkdiamond.com