

MK-S SCORING SAW OWNERS MANUAL, PARTS LIST & OPERATING INSTRUCTIONS



Revision 105	10.2011
Manual Part# 168238	

Caution: Read all safety and operating instructions before using this equipment. This owner's manual **MUST** accompany the equipment at all times.

INTRODUCTION

Congratulations on your purchase of a MK-S Scoring Concrete Saw. We are certain that you will be pleased with your purchase. MK Diamond takes pride in producing the finest construction power tools and diamond blades in the industry.

Operated correctly, your MK-S Scoring Concrete Saw should provide you with years of service. In order to help you, we have included this manual. This owners manual contains information necessary to operate and maintain your MK-S Scoring Concrete Saw safely and correctly. Please take the time to familiarize yourself with the MK-S Scoring Concrete Saw by reading and reviewing this manual.

Read and follow all safety, operating and maintenance instructions.

If you should have questions concerning your MK-S Scoring Concrete Saw, please feel free to call our friendly customer service department at: 800 421-5830

Regards,

MK Diamond

NOTE THIS INFORMATION FOR FUTURE USE:

MODEL NUMBER:	
SERIAL NUMBER:	
PURCHASE PLACE:	
PURCHASE DATE:	

NOTE: For your (1) one year warranty to be effective, complete the warranty card (including the Serial Number) and mail it in as soon as possible.

TABLE OF CONTENTS

SAFETY

Safety Messages	4
Damage Prevention Message	4
General Safety Precautions	5-7
California Proposition 65 Message	8
Safety Label Locations	9
Product Specifications	10

UNPACKING and ASSEMBLY

Unpacking	11
Contents	11
Assembly	12
Setup	13
Startup	14
Operation	15

VACUUM KIT

Vacuum Kit	16
------------	----

EXPLODED VIEW & PARTS LIST

Exploded View Part# 168151 & Parts List	18-19
Exploded View Part# 168186 & Parts List	20-21
Exploded View Part# 154741 & Parts List	22-23
Exploded View Part# 168174 & Parts List	24
Exploded View Part# 168183 & Parts List	25

THEORY

Theory Of Diamond Blades	26
--------------------------	----

ORDERING and RETURN INSTRUCTIONS

Ordering Information	27
Return Material Policy	27
Packaging Instructions	27
Authorized Service Centers	27

Safety precautions should be followed at all times when operating this equipment. Failure to read and understand the Safety Precaution and Operating Instructions could result in injury to yourself and others.

This Operation Manual has been developed to provide complete instructions for the safe and efficient operation of the MK-S Scoring Concrete Saw.

Before using this saw, ensure that the person operating the equipment has read and understands all instructions in this manual.

SAFETY MESSAGE / ALERT SYMBOLS

A safety message alerts you to potential hazards that could hurt you or others. Each safety message is preceded by a safety alert symbol () and one of three words: **DANGER**, **WARNING**, or **CAUTION**.

DANGER

You **WILL** be **KILLED** or **SERIOUSLY INJURED** if you do not follow directions.

WARNING

You **CAN** be **KILLED** or **SERIOUSLY INJURED** if you do not follow directions.

CAUTION

You **CAN** be **INJURED** if you do not follow directions. It may also be used to alert against unsafe practices.

Each message tells you what the hazard is, what can happen, and what you can do to avoid or reduce injury. Other important messages are preceded by the word **NOTICE**.

NOTICE

You can cause **PROPERTY DAMAGE** to your machine if you don't follow directions.

The safety labels should be periodically inspected and cleaned by the user to maintain good legibility at a safe viewing distance. If the label is worn, damaged or illegible, it should be replaced. Contact MK Diamond or your dealer for replacement.

DAMAGE PREVENTION AND INFORMATION MESSAGES

A Damage Prevention Message is to inform the user of important information and/or instructions that could lead to equipment or other property damage if not followed. Information messages convey information that pertains to the equipment being used. Each message will be preceded by the word **NOTE**, as in the example below.

NOTE: Equipment and/or property damage may result if these instructions are not followed.

GENERAL SAFETY PRECAUTIONS AND HAZARD SYMBOLS

SAFETY PRECAUTIONS

In order to prevent injury, the following safety precautions and symbols should be followed at all times!

GENERAL SAFETY



DO NOT operate or service this equipment before reading this entire manual.

This equipment should not be operated by persons under 18 years of age.

NEVER operate this equipment when not feeling well due to fatigue, illness or taking medicine.

NEVER operate this equipment under the influence of drugs or alcohol.

Whenever necessary, replace nameplate, operation and safety decals when they become difficult to read.

ALWAYS store equipment properly when it is not being used. Equipment should be stored in a clean, dry location out of the reach of children.

KEEP GUARDS IN PLACE



In order to prevent injury, keep guards in place and in working order at all times.

ENGINE OVER-SPEED



Never tamper with the governor components or settings to increase the maximum speed of the machine. Severe personal injury and/or equipment damage could result if the equipment is operated speeds above design maximum.

ACCIDENTAL STARTS



Before starting the engine, be sure the ON/OFF switch is in the "OFF" position to prevent accidental starting. Place the ON/OFF switch in the OFF position before performing any service operation.

ROTATING OR MOVING PARTS



Keep hands, feet, hair, and clothing away from all moving parts to prevent injury. Never operate a power tool with shrouds or guards removed.

HOT PARTS



Engine components can become extremely hot from operation. To prevent severe burns, do not touch these areas while the engine is running, or immediately after it is turned off. Never operate the engine with heat shields removed.

ALWAYS USE SAFETY GLASSES

Safety glasses should always be worn when working around power tools. Everyday eye-glasses only have impact resistant lenses and may not prevent eye injury; they are NOT safety glasses.

ALWAYS USE RESPIRATORY PROTECTION

Exhaust gases may be harmful if inhaled. Do not operate gas-powered equipment in enclosed spaces. Respiratory protection should be worn when operating gas powered equipment.

ALWAYS USE HEARING PROTECTION

To reduce the possibility of hearing loss, always use hearing protection when operating equipment.

REMOVE ADJUSTING KEYS AND WRENCHES

Form a habit of checking to see that keys and adjusting wrenches are removed from the power tool before it is turned on.

KEEP WORK AREA CLEAN

Cluttered work areas and benches invite accidents.

DO NOT USE IN DANGEROUS ENVIRONMENTS

Do not operate equipment in dangerous environments. Always keep the work area well lighted.

KEEP CHILDREN AWAY

All visitors and children should be kept a safe distance from work area.

MAKE WORKSHOP KID PROOF

Make the workshops kid proof by using padlocks, master switches or by removing starter keys.

DO NOT FORCE THE TOOL

A power tool will do a job better and safer operating at the rate for which it was designed.

USE THE RIGHT TOOL

Do not force a tool or an attachment, to do a job that it was not designed to do.

WEAR PROPER APPAREL

Do not wear loose clothing, gloves, neckties, rings, bracelets, or other jewelry that may be caught in moving parts. Non-slip footwear is recommended. Wear protective hair covering to contain long hair.

SECURE WORK

Clamps or a vise should be used to hold work whenever practical. Keeping your hands free to operate a power tool is safer.

DO NOT OVERREACH

Keep proper footing and balance at all times by not overreaching.

MAINTAIN TOOLS WITH CARE

Keep tools sharp and clean for the best and safest performance. Always follow maintenance instructions for lubricating and when changing accessories.

SHUT DOWN TOOL

The saw should always be shutdown before servicing or when changing accessories such as blades, bits, cutters, etc...

USE RECOMMENDED ACCESSORIES

Consult the owner's manual for recommended accessories. Using improper accessories may increase the risk of personal or by-stander injury.

NEVER STAND ON THE TOOL

Serious injury could occur if a power tool is tipped, or if a cutting tool is unintentionally contacted.

NEVER LEAVE TOOL RUNNING UNATTENDED – TURN POWER OFF

Do not leave a tool until it comes to a complete stop. Always turn a power tool OFF when leaving the work area, or, when a cut is finished.

CHECK FOR DAMAGED PARTS

Before using a power tool, check for damaged parts. A guard or any other part that is damaged should be carefully checked to determine it would operate properly and perform its intended function. Always check moving parts for proper alignment or binding. Check for broken parts, mountings and all other conditions that may affect the operation of the power tool. A guard or any damaged part should be properly repaired or replaced.

DIRECTION OF FEED

Always feed work into a blade or cutter against the direction of rotation. A blade or cutter should always be installed such that rotation is in the direction of the arrow imprinted on the side of the blade or cutter.

SILICA DUST WARNING

Grinding/cutting/drilling of masonry, concrete, metal and other materials with silica in their composition may give off dust or mists containing crystalline silica. Silica is a basic component of sand, quartz, brick clay, granite and numerous other minerals and rocks. Repeated and/or substantial inhalation of airborne crystalline silica can cause serious or fatal respiratory diseases, including silicosis. In addition, California and some other authorities have listed respirable crystalline silica as a substance known to cause cancer. When cutting such materials, always follow respiratory precautions.

CALIFORNIA PROPOSITION 65 MESSAGE

Some dust created by power sanding, sawing, grinding, drilling, and other construction activities contain chemicals known (to the State of California) to cause cancer, birth defects or other reproductive harm. Some examples of these chemicals are:

- Lead, from lead-based paints
- Crystalline silica, from bricks and cement and other masonry products
- Arsenic and chromium, from chemically treated lumber

For further information, consult the following sources:

<http://www.osha.gov/dsg/topics/silicacrystalline/index.html>

<http://www.cdc.gov/niosh/consilic.html>

<http://oehha.ca.gov/prop65/law/P65law72003.html>

<http://www.dir.ca.gov/Title8/sub4.html>

Your risk from these exposures varies depending on how often you do this type of work. To reduce your exposure to these chemicals, work in a well-ventilated area, and work with approved safety equipment, such as those dust masks that are specially designed to filter out microscopic particles.

Before starting the machine, **ALWAYS** check that all guards are in position and correctly fitted. Check the machine for loose bolts before starting.

Keep area around the machine clear of obstructions which could cause persons to fall onto moving parts.

ALWAYS ensure that the machine is on level ground before using. Know how to stop the machine quickly in case of emergency. **NEVER** try to stop a moving blade with your hands.

- **NEVER** disconnect any “emergency or safety devices”. These devices are intended for operator safety. Disconnection of these devices can cause severe injury, bodily harm or even death! Disconnection of any of these devices will void all warranties.
- Unauthorized equipment modifications will void all warranties. Manufacturer does not assume responsibility for any accident due to equipment modifications.
- **NEVER** use accessories or attachments, which are not recommended by MK Diamond for this equipment. Damage to the equipment and/or injury to user may result.



WARNING

DO NOT use woodcutting, or carbide blades on this machine! Use **ONLY** Diamond blades on machine. Use machine only to cut tile and masonry products. **DO NOT** use machine to cut wood or wood products.

OPERATION & SAFETY DECALS

The MK-S Scoring Concrete Saw is equipped with safety decals. These decals is provided for operator safety and maintenance information. Should any of these operation or safety decals become unreadable, replacements can be obtained by calling **(800) 262-1575**.

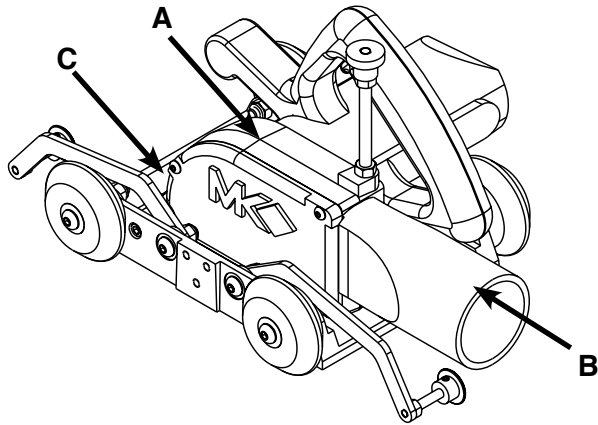

A



B



C



<u>Location</u>	<u>Description</u>
A Shroud	Proposition 65, Dust Warning
B Port	Read Manual
C Base	Service or Repair

PRODUCT SPECIFICATIONS

This is an electric powered Scoring Concrete Saw. Operated and used according to this manual, the MK-S will provide years of dependable service.

Power	Electric
Motor Speed	11,000 RPM
Amps	9.1
Volts	120v 50/60 Hz
Blade Capacity	4"
Depth of Cut	1/2"
Arbor	20 mm
L x W x H (inches)	15" x 11" x 9"
L x W x H (mm)	381 x 279 x 229
Weight	13.5 lbs. (6 kg) (not including pivot base)
Part#	168151

Blade

The MK-S uses a 4 inch diameter diamond blade, fits blades .090 to .375 wide.

Concrete Saw Usage

The MK-S is designed to score various grades of concrete surfaces.

Features

- Spring-loaded head allows users to easily insert and retract blade from cut
- Front and rear roller guides for precise cutting
- 2-1/2" dust outlet provides virtually dust free cutting when attached to the appropriate dust collector
- Cutting depth easily adjusted by a thumb-screw (no tools required)
- Aluminum base lightweight machine for easy one person operation and transport
- Ball-bearing wheels move easily providing precision cuts
- Cuts circles down to a 9.75" diameter without damaging the floor

UNPACKING

Your MK-S has been shipped from the factory thoroughly inspected. Only minimal assembly is required.

Remove the MK-S from the carton and place it on a flat surface.

CONTENTS

In the containers, you will find one (1) MK-S, one (1) Diamond Blade, one (1) Blade Shaft Wrench, one (1) Allen Wrench, (1) MK-S Owners Manual, one (1) Motor Owners Manual and one (1) Warranty card.



MK-S Saw



Diamond
Blade



Blade Shaft
Wrench



Allen
Wrench



MK-S
Owner's Manual



Motor Manual

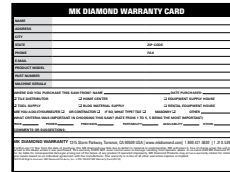

Warranty
Card

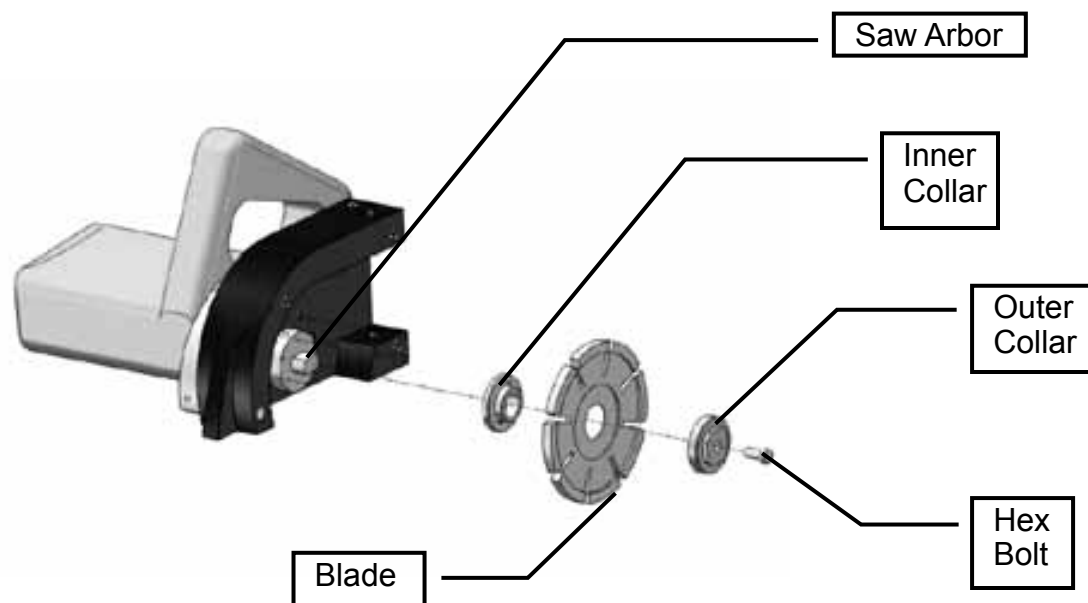

BLADE INSTALLATION DIAGRAM

Note: The base assembly is not shown for clarity.

Install the inner collar over the saw arbor. Slide the blade over the shoulder of the bottom collar until the blade is seated flat against the collar. Place the outer collar over the remaining portion of the inner collar's shoulder. Insert the Hex Bolt into the outer collar and tighten by hand, turning counter-clockwise (left hand thread).

Slide the Makita wrench onto the flats of the outer collar. While holding the Makita wrench, place the socket wrench over the hex nut and tighten, counter-clockwise, until secure.

Rotate the shroud cover back to the original position and re-install the shroud cover screws.

Before the first use, check all fasteners for tightness and review all Safety and Operating Instructions.

Before beginning the cutting work, check daily for regular tightness of all fasteners, especially those attaching the blade to the saw.

Before switching the saw on, make sure that all protective housings are fitted and the dust collector unit is correctly connected.

Handle all plugs, cables, hoses and operating elements carefully. Avoid contact with live wires.

Before cutting, clean the surface with a broom. There should not be any trash, stones, cloths or standing liquid on the surface.

Put the decorative saw and the required accessories onto the surface to be processed.

Assemble the center pivot base, as required for the application.

Fit the appropriate blade that is required for this particular process.

Using the correct cables, connect the machine and the dust collector to the electricity supply point. These electric supply points should be protected and equipped with a GFCI Switch. (Residual current operated device). In case of doubt, ask the local safety officer.

PRE-START INSPECTION

The pre-start inspection should be performed before beginning any job. If Diamond Blade is worn, replace the blade before starting work.

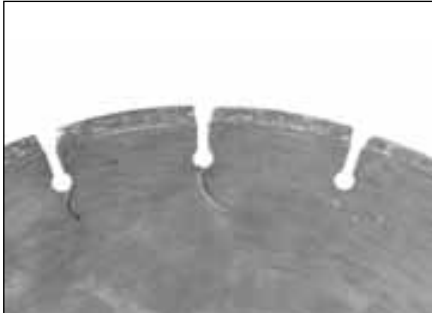

Inspect Blade for damage. Verify the Blade is correct for the material being cut.



Inspect the MK-S for general damage and/or loose hardware.

MAINTENANCE SAFETY

- **NEVER** lubricate components or attempt service on a running machine.
- Keep the machinery in proper running condition.
- Fix damage to the machine immediately and always replace broken parts, or missing decals.

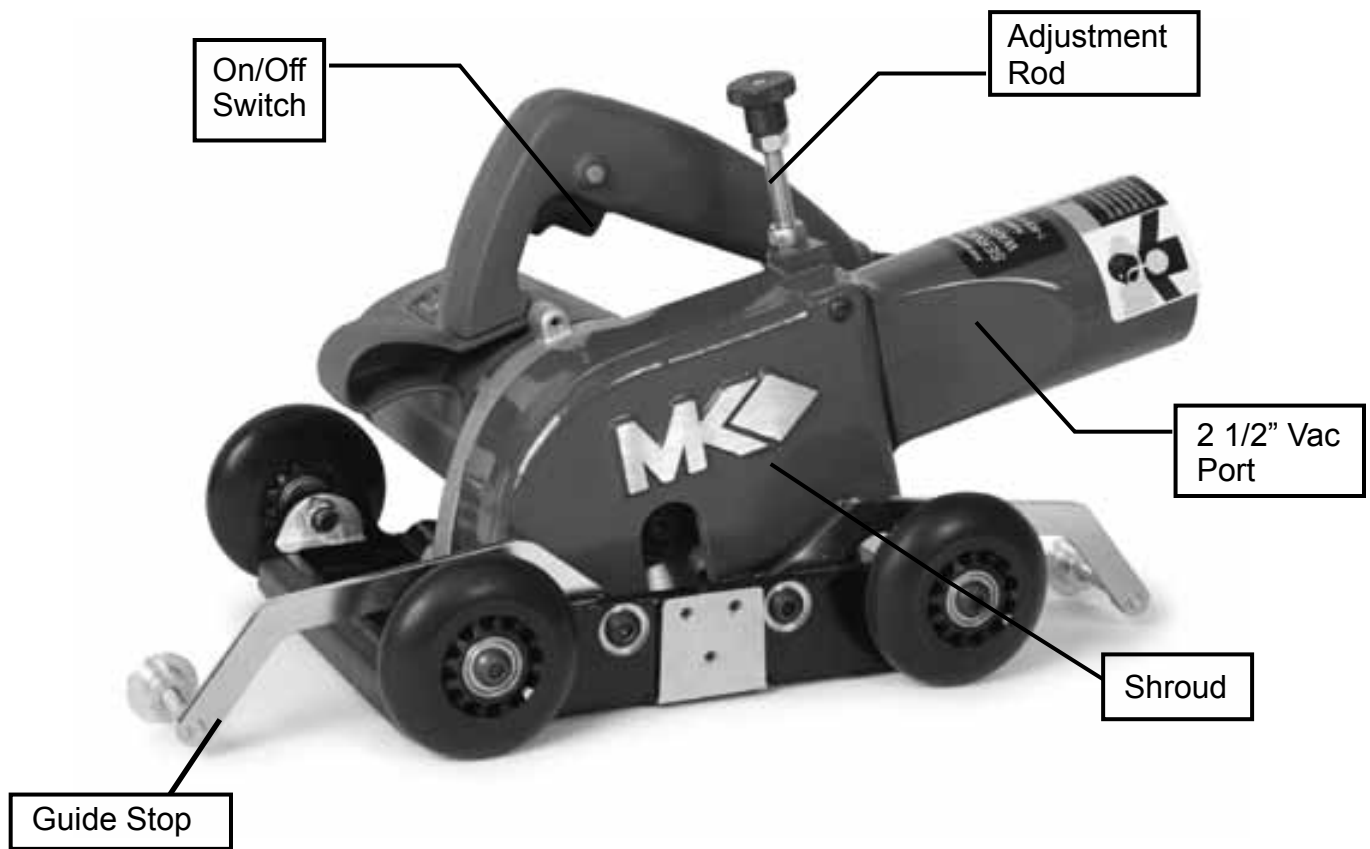

Line up the front and rear guide stops with the blade and tighten the set screws. Use the set screws on the guide stop to secure the guide in position.

Using the adjustment rod located on the top of the saw shroud, set the cutting depth of the blade. By tightening the adjustment rod or threading it downward, you will reduce the cut depth. The adjustment rod provides a stop which controls the cut depth. Once set, tighten the jam nut against the top of the shroud to secure the adjustment rod setting.

Attach the dust collector hose into the 2 1/2" Vac port. Plug the saw and the dust collector into the appropriate power source(s).

VACUUM KIT

The Vacuum Pivot Kit (part #168186) is used for radius and circular cutting. The kit consists of one base, one vacuum pump, one air hose and four pivot bars.



Place the three bolts into center pivot mounting bracket and screw into to saw



Place base on clean, flat surface and attach air hose to base by pulling back collar and sliding onto coupling.



Place the clamp on the center screw.



Screw pivot bar into center pivot mounting bracket on saw.



Slide the pivot bar into clamp. Adjust to proper radius.

NOTE: Add additional pivot bars to increase radius of cut.

FOR PERFECT CIRCLES AND ARCS

Set up vacuum base and mark cut with soap stone by rotating pivot bar







Attach saw to pivot bar

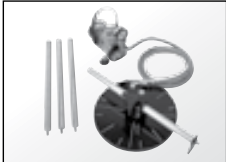

Adjust depth of cut and begin cutting

ACCESSORIES

DESCRIPTION	PART #	PHOTO
<p>Vacumm Pivot Kit</p> <p>For making precise circles and arc. Includes vacuum base, pump, air hose, and four pivot bars.</p>	<p>168186</p>	
<p>MK-404 DV</p> <p>Supreme V-Segment Crack Chaser Diamond Blade</p> <p><i>Request 20mm bushing when ordering</i></p>	<p>156048</p>	
<p>MK-404 DT</p> <p>Supreme Tuck Point Diamond Blade</p> <p><i>Request 20mm bushing when ordering</i></p>	<p>151112</p>	
<p>MK-925 D</p> <p>General Purpose Turbo Supreme Diamond Blade</p> <p><i>Request 20mm bushing when ordering</i></p>	<p>150667Y</p>	

Part# 168151

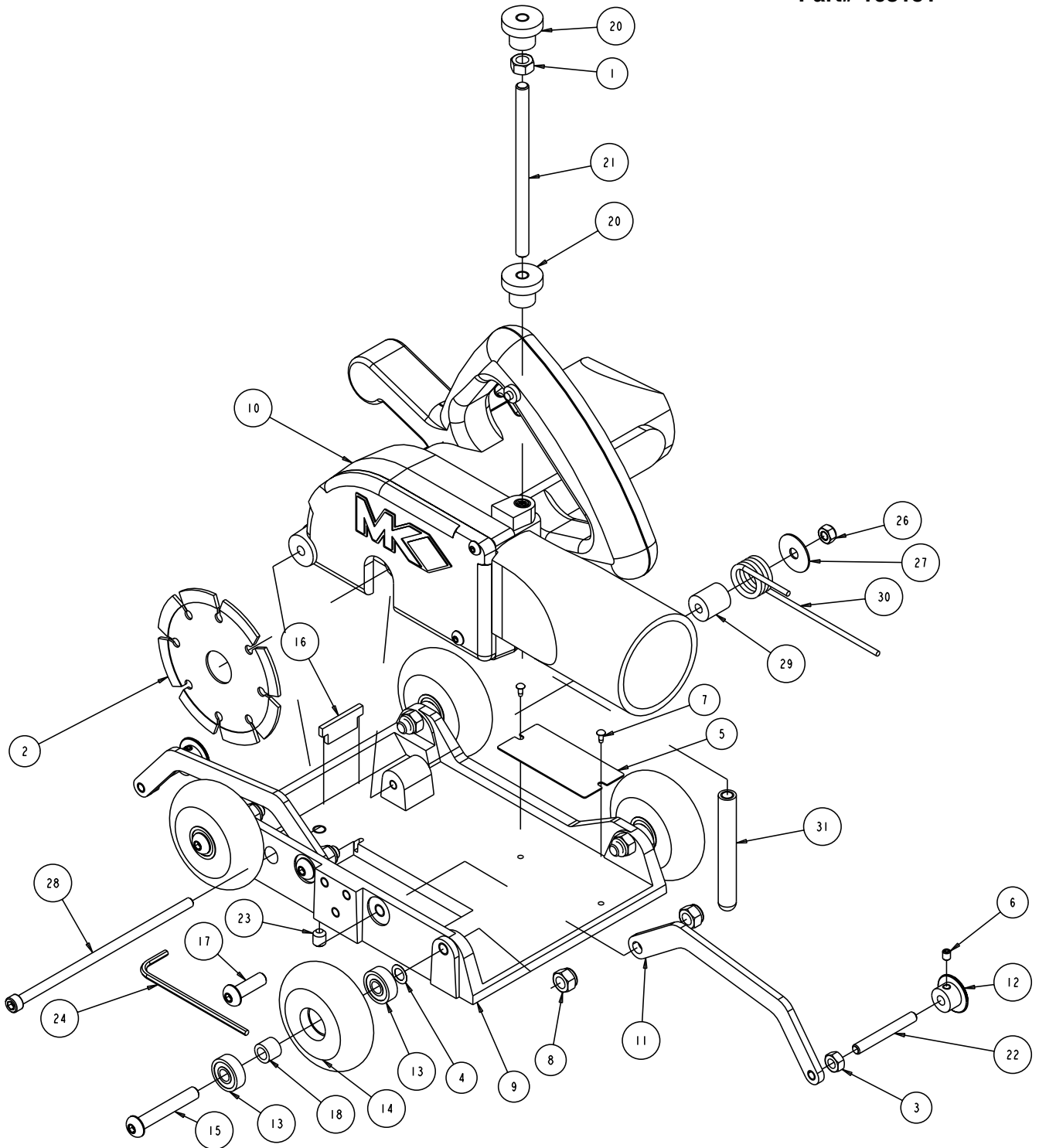

ITEM	DESCRIPTION	QTY.	PART#
1	NUT, HEX, 5/16 - 18	2	101196
2	BLADE, MK-304D 4 X 080X 20MM - 5/8	1	150686
3	NUT, HEX, 1/4 - 20	2	151893
4	SHIM, 1/2 OD X 5/16 ID X .004" THK.	4	152519
5	TAG, SERIAL NUMBER, BLANK	1	157500-RW
6	SCREW, SOCKET HEAD SET 10 -24 X 1/4	2	157552
7	DRIVE SCREW, #7 X 5/16 ROUND HEAD	2	157849
8	NUT, HEX, NYLK, 5/16 - 18	6	158289
9	CASTING, BASE COMP	1	168169
10	ASSY, CUTTING HEAD	1	168174
11	ARM, POINTER	2	168175
12	WHEEL, POINTER	2	168176
13	BEARING, WHEEL	8	168177
14	WHEEL, RUBBER 72MM	4	168178
15	SCREW, BHCS, 5/16 - 18 X 2	4	168195
16	WIPER, RUBBER	1	168217
17	SCREW, BHCS, 5/16 - 18 X 1	2	168219
18	SPACER, WHEEL 8MM X 12.7MM X 10MM	4	168235
19	OWNERS, MANUAL, MK-S	1	168238
20	KNOB, 5/16 - 18 X 1	2	168239
21	STUD, 5/16 - 18 X 5	1	168240
22	STUD, 1/4 - 20 X 2-1/2	2	168241
23	SCREW, SOC HD SET, 5/16 18 X 3/8	1	168242
24	WRENCH, 1/8 HEX KEY	1	168263
25	LABEL, CARTON, MK-S	1	168553
26	NUT, HEX, NYLK, M6 - 1.0	1	168048
27	WASHER, FENDER, 1/4 X 1	1	168049
28	SCREW, CAP, SOC HD, M6 X 1 X 150MM	1	169050
29	SPACER, 1/4 X 11/16 X 3/4	1	168051
30	SPRING, TORSION, 35 IN-LB	1	168052
31	PIN, STOP, THREADED	1	168085

MK-S Scoring Saw Kit, Vacuum
Part# 168186

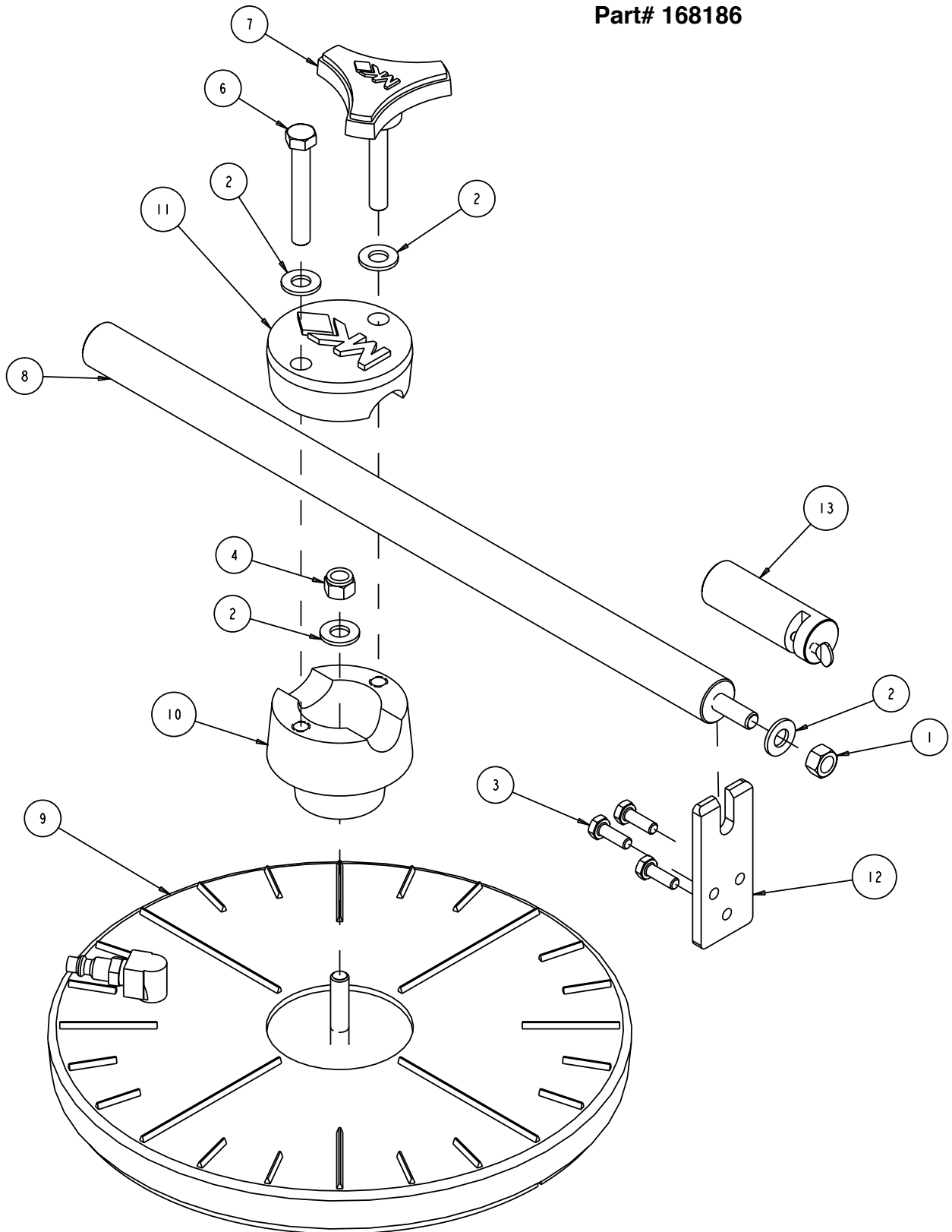

ITEM	DESCRIPTION	QTY.	PART#
1	NUT, 3/8 - 16 HEX	1	101188
2	WASHER 3/8 SAE FLAT	4	150923
3	SCREW, HEX HD, 1/4 - 20 X 3/4	3	152370
4	NUT, 3/8 - 16 NYLOK HEX	1	152505
5	ASSY, VACUUM PUMP W/HANDLE 110V	1	154741
6	BOLT, 3/8 -16 X 2-1/2 HEX HEAD TAP	1	155589
7	KNOB, TRI PLASTIC MK-770 2-1/4	1	156770-04
8	ASSY, PIVOT BAR	1	168182
9	ASSY, VACUUM BASE	1	168183
10	CASTING, BOSS, PIVOT, - COMP	1	168189
11	CASTING, CAP, PIVOT, - COMP	1	168191
12	BRACKET, CENTER	1	168198
13	ASSY, MARKER HOLDER	1	168247

**Common Part Assy, Vacuum Pump
w/handle 110V
Part# 154741**

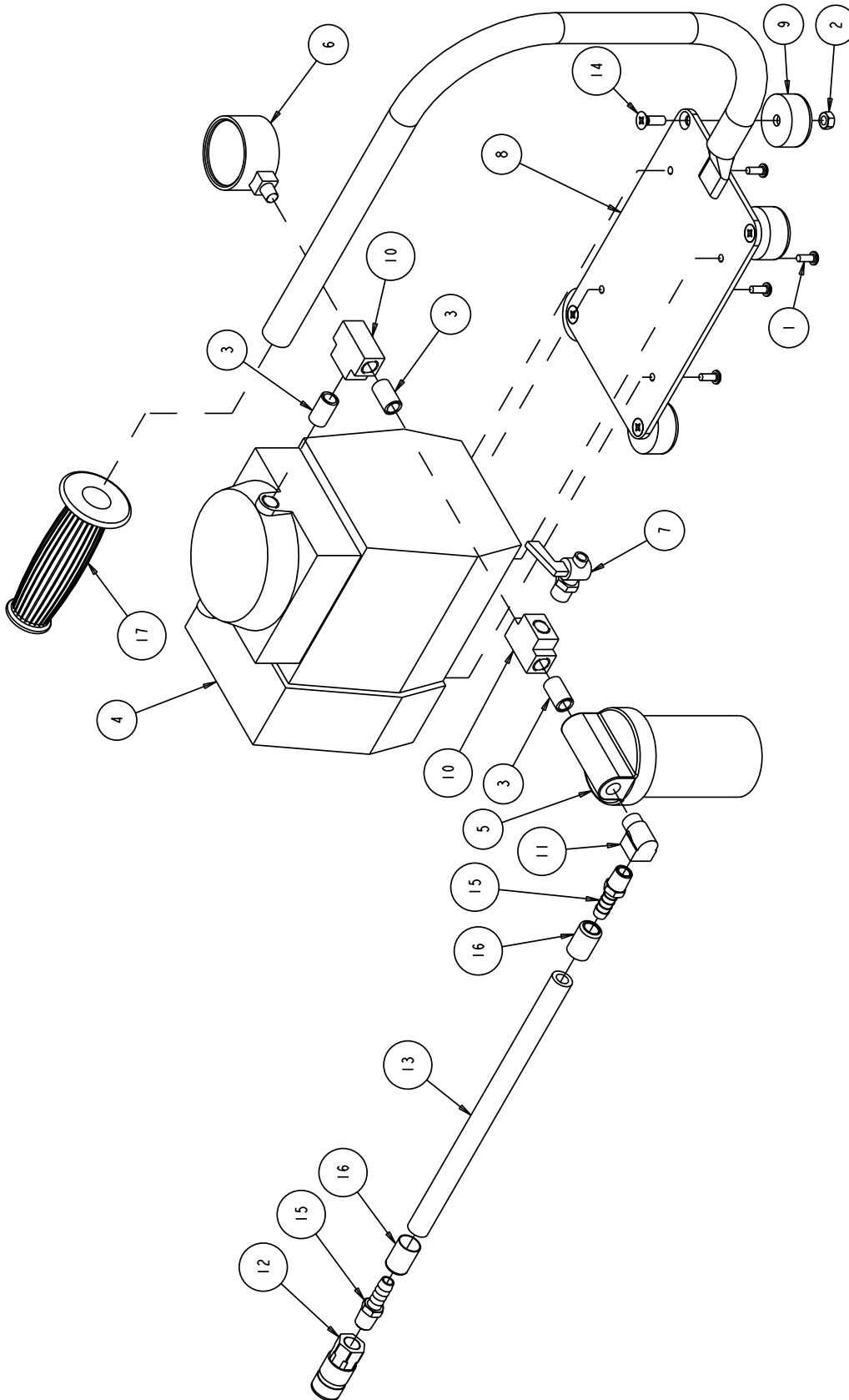

ITEM	DESCRIPTION	QTY.	PART#
1	SCREW, 10-32 X 1/2 PAN HEAD PHILLIPS MACHINE	4	151052
2	NUT, HEX, 14 - 20	4	151893
3	NIPPLE, 1/4 NPT X CLOSE GALV	3	152598
4	PUMP, VACUUM MANTA CORE DRILL	1	154475
5	FILTER, WATER	1	154476
6	GAUGE, VACUUM	1	154477
7	VALVE, PETCOCK 1/4" MIP	1	154488
8	BASE, VACUUM PUMP	1	154495
9	BUPER, 1-12/ OD X 1/4 ID X 3/4	4	154496
10	FITTING, T 1/4 X 1/4 X 1/4 NPT	2	154497
11	ELBOW, 1/4MNPT STREET	1	154615
12	COUPLER, BODY 1/4 FNPT	1	154617
13	HOSE, AIR 3/8" ID, 6'	1	154656
14	SCREW, 1/4 - 20 X 3/4 FLAT HEAD PHILLIPS MACHINE	4	154657
15	FITTING, 1/4 MNPT X 3/8 BARB	2	154659
16	HOSE, FERRULE .625 ID BRASS	2	154660
17	GRIP, HANDLE 7/8 ID	1	158608

Part# 168174
Cutting Head Assembly

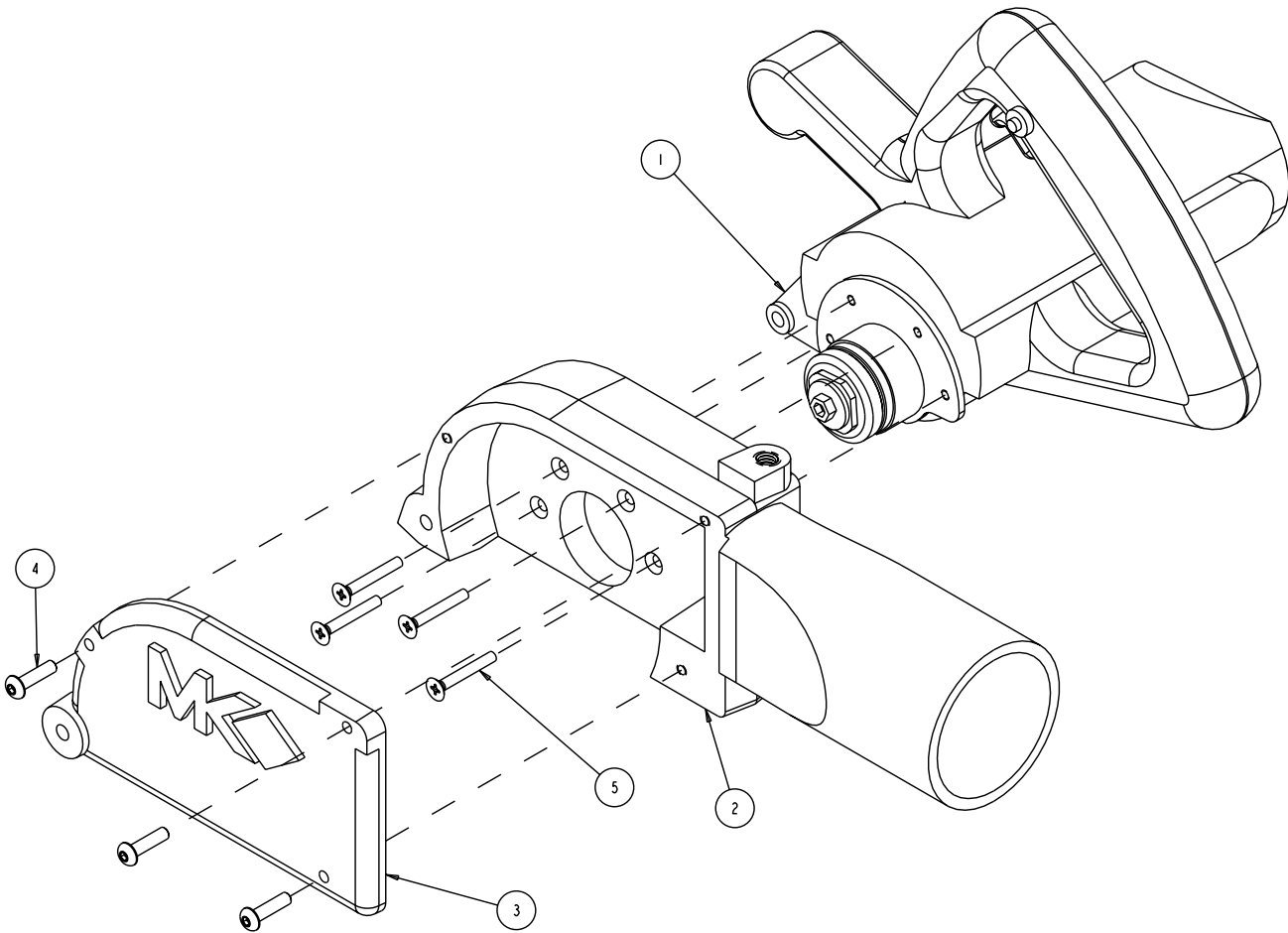

ITEM	DESCRIPTION	QTY.	PART#
1	SAW, MAKITA	1	168149
2	CASTING, MOTOR MT-COMP	1	168171
3	CASTING, COVER, COMP	1	168173
4	SCREW, BHCS, #10 - 24 X3/4	3	168216
5	SCREW, FLAT HD, M4 - 7 X 30MM	4	168220

Part# 168183
Vacuum Base Assembly

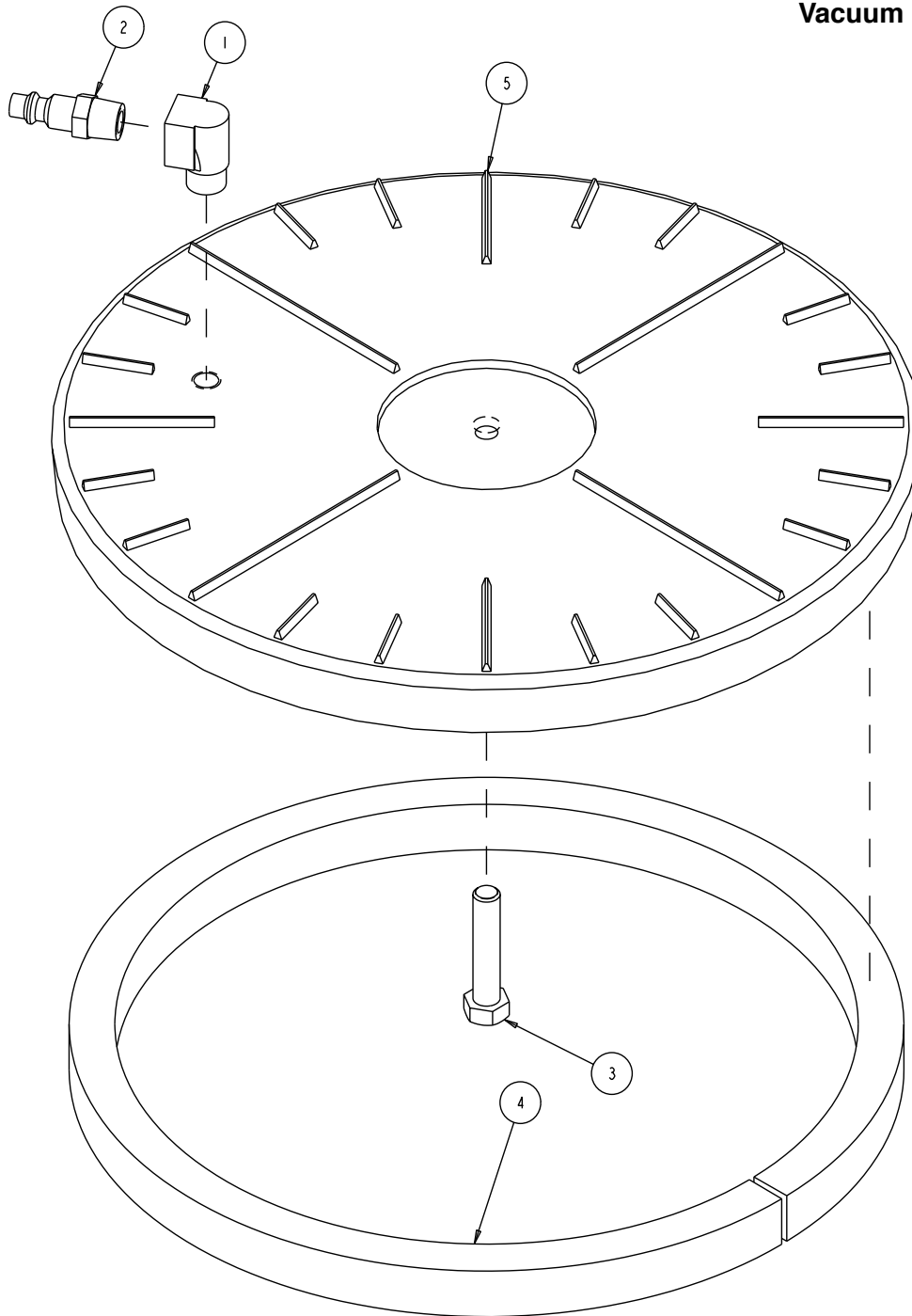

ITEM	DESCRIPTION	QTY.	PART#
1	ELBOW, 1/4MNPT STREET	1	154615
2	COUPLING, PLUG, 1/14 X 1/4MNPT	1	154658
3	SCREW, 3/8 -16 X 1-3/4 HEX HD	1	158398
4	GASKET, 5/8 X 3/4 X 36	1	168185
5	CASTING, VACUUM BASE-COMP	1	168194

ORDERING INFORMATION

You may order MK Diamond products through your local MK Diamond distributor or, you may order direct from MK Diamond.

When ordering direct from MK Diamond, please have the following information ready before calling:

- The Model Number of the saw
- The Serial Number of the saw
- Where the saw was purchased and when
- The Part Number for the part(s) being ordered
- The Part Description for the part(s) being ordered

NOTE: There is a \$25.00 minimum order when ordering direct from MK Diamond. A \$5.00 charge will be added to orders having a net billing value under \$50.00. All purchases must be made using VISA, MasterCard or American Express.

All parts may be ordered by calling toll free to – 800 421-5830 or 310 539-5221 and asking for Customer Service. For technical questions, call – 800 474-5594.

RETURN MATERIALS POLICY

To expedite the service relative to the return of a product purchased through MK Diamond, please observe the following:

NOTE: When returning all items, they must have been purchased within the previous twelve (12) months.

- Have the Model Number of the saw
- Have the Serial Number of the saw
- Have the location of where the saw was purchased
- Have the date when the saw was purchased
- Contact Customer Service for approval to return the item(s)
- Obtain a Returned Goods Number (RGA) authorizing the return
- Follow the packaging instructions in the following section
- Ensure your item(s) are prepaid to the destination

For returned items, call toll free to – 800 421-5830 or 310 539-5221 and ask for Customer Service. For technical questions, call – 800 474-5594 or 310 257-2845.

PACKAGING INSTRUCTIONS

- Remove the Cutting Head and Support Angle Assembly
- Dry the saw before shipping
- When packing, include the following: Saw, Diamond Blade, Blade Guard and Support Angle Assembly and Adjustable Cutting Guide (Other Accessories are not required)
- Package the unit in its original container or one of comparable size (do not ship the unit partially exposed)
- Ensure all parts are secured in the packaging to prevent moving

AUTHORIZED SERVICE CENTERS

For quicker repair time, you may contact MK Diamond Customer Service, toll free, at 800 421-5830 or 310 539-5221 for the Authorized Service Center closest to you or visit our web site at www.mkdiamond.com. For technical questions, call – 800 474-5594.

CONTACT:

Please contact MK Diamond Products, Inc. Customer Service Department with any questions you might have regarding distributors, parts or service.

Telephone: **(800) 421-5830**

Fax: **(310) 539-5158**

E-mail: **Customer_Service@MKDiamond.com**

Customer Service Hours: **Monday through Friday, 6AM-4PM PST**

MK Diamond Products, Inc.
1315 Storm Parkway
Torrance, CA 90501

MK DIAMOND PRODUCTS, INC. LIMITED WARRANTY

MK DIAMOND PRODUCTS, INC. will guarantee every machine they build, to be free from defects in material and workmanship for (1) one year from date of purchase. The obligation of MK DIAMOND PRODUCTS, INC. under this warranty is limited to the repair or replacement of any parts which, under normal use, prove to be defective in material or workmanship. The parts involved or the unit in question should be returned to MK DIAMOND PRODUCTS, INC. or to a point designated by us, transportation prepaid.

This warranty does not obligate us to bear the cost of labor or transportation charges in connection with replacement or repair of defective parts. Likewise, it shall NOT apply to any unit which has been subjected to misuse, neglect or accident. This warranty does NOT apply to any machine which has been repaired or altered outside our factory.

This warranty does NOT obligate MK DIAMOND PRODUCTS, INC., with respect to items not of our manufacture, such as engines, motors, hydraulics, etc., which are subject to their own guarantees and warranties.

We shall in no event be liable for consequential damages or contingent liabilities arising out of failure of any equipment or parts to operate properly.

© COPYRIGHT 2011, MK DIAMOND PRODUCTS, INC. ALL RIGHTS RESERVED.

The MK Diamond logo is a registered trademark of MK Diamond Products, Inc. and may not be used, reproduced, or altered without written permission. All other trademarks are the property of their respective owners and used with permission.

MK Diamond may have patents, patent applications, trade marks, copyrights of other intellectual property right covering this product in this document.

This manual MUST accompany the equipment at all times. This manual is considered a permanent part of the equipment and should remain with the unit if resold.

The information and specifications included in this publication were in effect at the time of approval for printing.

MK-S SCORING SAW
OWNERS MANUAL & OPERATING INSTRUCTIONS



MK Diamond Products, Inc.
1315 Storm Parkway
Torrance, CA 90501

Toll-Free: (800) 421-5830
Phone: (310) 539-5221
Fax: (310) 539-5158
www.mkdiamond.com