

CANOGA 193-E SERIES
CONCRETE MIXER (ELECTRIC)
OPERATOR'S MANUAL



Revision 204	08.2013
Manual Part No. 166135	

Caution: Read all safety and operating instructions before using this equipment. This manual **MUST** accompany the equipment at all times.

Congratulations on your purchase of a Canoga Mixer. We are certain that you will be pleased with your purchase. Canoga takes pride in producing the finest construction power tools and diamond blades in the industry.

Operated correctly, your Mixer should provide you with years of service. In order to help you, we have included this manual. This owners manual contains information necessary to operate and maintain your Mixer safely and correctly. Please take a few minutes to familiarize yourself with the saw by reading and reviewing this manual.

If you should have questions concerning your saw, please feel free to call our friendly customer service department at: 800 421-5830

Regards,



NOTE THIS INFORMATION FOR FUTURE USE:

MODEL NUMBER:	
SERIAL NUMBER:	
PURCHASE PLACE:	
PURCHASE DATE:	

NOTE: For your (1) one year warranty to be effective, complete the warranty card (including the Serial Number) and mail it in as soon as possible.

CANOGA 193 SERIES CONCRETE MIXER**PAGE #****SAFETY**

Safety Message/Alert Symbols	4
Hazard Symbols	5
Rules for Safe Operation	6-8
Operation & Safety Decals	10

PRODUCT SPECIFICATIONS

Mixer Dimensions & Decal Locations	11
Product Specifications	12
Mixer Basic Components	13

INSPECTION & START-UP

Electric Motor Safety	14-15
Electrical Requirements & Grounding Instructions	16-17
Electric Motor	18
Initial Start-Up (Electric Motor)	18-19

OPERATION

Concrete Mixing	20
Operation	21
Towing Guidelines	22-23
Safety Chain Connection	24

MAINTENANCE & TROUBLESHOOTING

Maintenance (Mixer)	25-27
Troubleshooting (Mixer)	28

GENERAL PRODUCT INFORMATION

Contact Information & Limited Warranty	30
Certificate of Origin for a Vehicle Request Form	31

Safety precautions should be followed at all times when operating this equipment. Failure to read and understand the Safety Precaution and Operating Instructions could result in injury to yourself and others.

This Operation Manual has been developed to provide complete instructions for the safe and efficient operation of the Canoga 193-E Series Concrete Mixer (Electric).

Before using these mixers, ensure that the person operating the mixer has read and understands all instructions in this manual.

SAFETY MESSAGE / ALERT SYMBOLS

A safety message alerts you to potential hazards that could hurt you or others. Each safety message is preceded by a safety alert symbol () and one of three words: **DANGER**, **WARNING**, or **CAUTION**.



DANGER You **WILL** be **KILLED** or **SERIOUSLY INJURED** if you **DO NOT** follow directions.



WARNING You **CAN** be **KILLED** or **SERIOUSLY INJURED** if you **DO NOT** follow directions.



CAUTION You **CAN** be **INJURED** if you **DO NOT** follow directions. It may also be used to alert against unsafe practices.

Each message tells you what the hazard is, what can happen, and what you can do to avoid or reduce injury. Other important messages are preceded by the word **NOTICE**.



NOTICE

You can cause **PROPERTY DAMAGE** to your machine if you don't follow directions.

The safety labels should be periodically inspected and cleaned by the user to maintain good legibility at a safe viewing distance. If the label is worn, damaged or illegible, it should be replaced.

Potential hazards associated with the Canoga 193-E Series Concrete Mixer (Electric) operation will be referenced with Hazard Symbols which appear throughout this manual, and will be referenced in conjunction with Safety Message Alert Symbols.

HAZARD SYMBOLS



ALWAYS read this Owner's Manual before operating the machine.



Avoid inhalation of and skin contact with silica dust and/or mist.



ALWAYS place the power ON/OFF switch in the **OFF** position when the mixer is not in use.



ALWAYS wear approved eye protection.



ALWAYS wear approved ear protection.



ALWAYS wear approved respiratory protection.



NEVER operate equipment with covers, or guards removed. Keep fingers, hands, hair and clothing away from all moving parts to prevent injury.



Use caution around gears. Keep fingers, hands, hair and clothing away from all moving parts to prevent injury.



DO NOT touch hot engine components while the machine is running or immediately after operating.



NEVER touch the power cord with wet hands or while standing in water when it is connected to a power source.



NEVER operate the machine in an explosive atmosphere or near combustible materials.

RULES FOR SAFE OPERATION



DANGER

Failure to follow instructions in this manual may lead to serious injury or even death! This equipment is to be operated by trained and qualified personnel only! This equipment is for industrial use only. The following safety guidelines should always be used when operating the Canoga 193-E Concrete Mixer (Electric).

GENERAL SAFETY



ALWAYS read this Owner's Manual before operating the machine. **DO NOT** operate or service this equipment before reading this entire manual. Read and understand all warnings, instructions and controls on the machine. Know how to stop the equipment quickly in case of emergency. It is the operators responsibility to use this machine under safe working conditions and conform with federal, state and local codes or regulations pertaining to safety, air, pollution, noise etc...



This equipment should not be operated by persons under 18 years of age.



NEVER operate this equipment without proper protective clothing, shatterproof glasses, steel-toed boots and other protective devices required by the job. Non-slip foot wear is recommended.



NEVER operate this equipment when not feeling well due to fatigue, illness or taking medicine.



NEVER operate this equipment under the influence of drugs or alcohol.



Whenever necessary, replace nameplate, operation and safety decals when they become difficult to read.



ALWAYS check the machine for loose bolts before starting.



PERSONAL PROTECTIVE EQUIPMENT

ALWAYS wear approved respiratory (mask), head, hearing and eye protection when operating the mixer.



NEVER place hands inside the drum while the drum is rotating.



ALWAYS store equipment properly when it is not being used. Equipment should be stored in a clean, dry location out of the reach of children



NEVER leave the mixer unattended. Turn off gasoline engine when unattended.



CAUTION must always be observed while servicing this mixer. Rotating parts can cause injury if contacted.



Ensure that any electrical extension cord is protected against damage. Always ensure that the electrical extension cord is not trapped underneath the mixer.



DO NOT allow extension cord to come into contact with water or fluids. **DO NOT** spray water onto electric motor.



DO NOT allow extension cord to come into contact with water or fluids. **DO NOT** spray water onto electric motor.



This mixer is intended for the production of concrete. Mixer must be used only for its intended purpose.



This mixer is not suitable for the mixing of flammable or explosive substances.



NEVER operate the mixer in an explosive atmosphere.



Before starting the mixer, check that all guards are in position and correctly fitted.



Keep area around the mixer clear of obstructions and trip hazards which could cause persons to fall onto moving parts.



ALWAYS ensure mixer is on level ground before mixing.



Become familiar with the controls of the mixer before operating.



Ensure the drum is rotating while filling and emptying the drum.



ALWAYS disconnect AC power plug from power source before moving mixer.



Make sure the OFF/ON power switch on the electric motor is always in the **OFF** position before inserting the mixer's power plug into an AC receptacle.



Operate electric motor only at the specified voltage indicated on the nameplate.



NEVER disconnect any “emergency or safety devices”. These devices are intended for operator safety. Disconnection of these devices can cause severe injury, bodily harm or even death! Disconnection of any of these devices will void all warranties.



Unauthorized equipment modifications will void all warranties. Manufacturer does not assume responsibility for any accident due to equipment modifications.



NEVER use accessories or attachments, which are not recommended by Canoga for this equipment. Damage to the equipment and/or injury to user may result.

MAINTENANCE SAFETY



NEVER lubricate components or attempt service on a running machine.



Keep the machinery in proper running condition.



Fix damage to the machine immediately and always replace broken parts or missing decals.

NOTES

OPERATION & SAFETY DECALS

The Canoga Mixer is equipped with a number of safety decals provided for operator safety and maintenance information. Should any of these decals become unreadable, replacements can be obtained by calling (800) 262-1575.

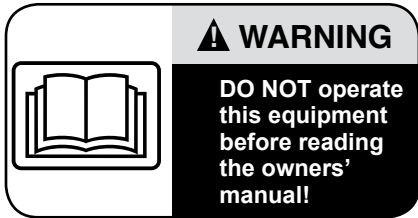

Decal A



Decal B

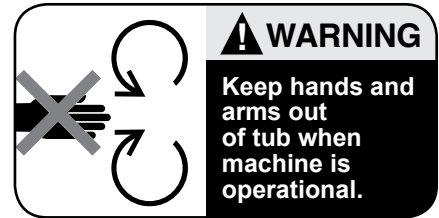

Decal C



Decal D



Decal E

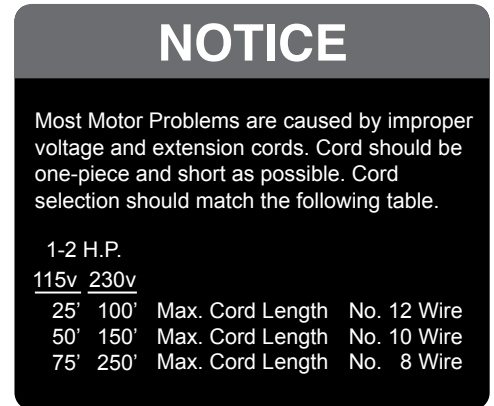

Decal G

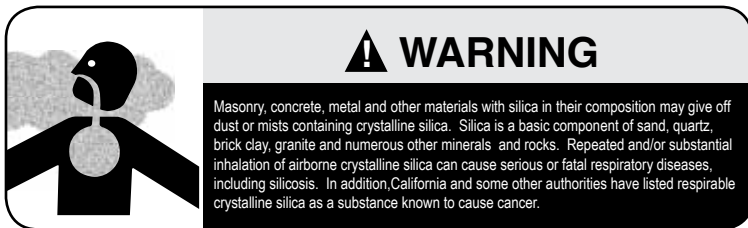

Decal F



Decal H



Decal I



Decal J

Canoga 193-E Safety Decal Sheet, Part No. 166008

MIXER SPECIFICATIONS & DECAL LOCATIONS

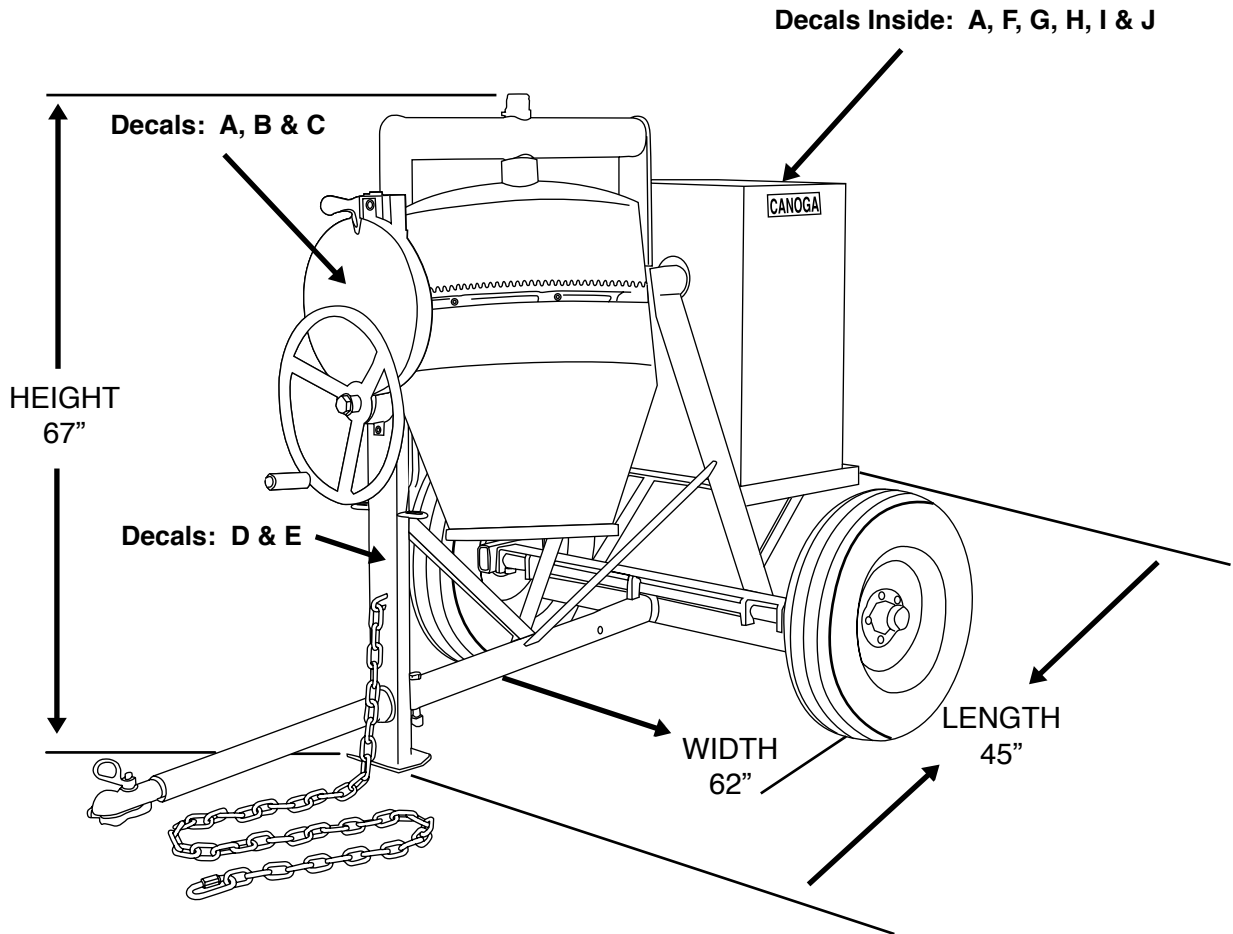

Mixer Dimensions and Decal Locations

Decal	Location	Description
A	Dump Gear Guard and Inside Motor Cabinet	Warning Read Manual Before Operating Equipment
B	Dump Gear Guard	Caution Guards in Place
C	Dump Gear Guard	Warning Keep Hands and Arms Out of Tub
D	Front Leg	Caution Fasten Safety Chain Before Towing
E	Front Leg	Warning Maintain Tire Pressure
F	Inside Motor Cabinet	Warning Silica Dust Hazard
G	Inside Motor Cabinet	Notice Extension Cord Warnings
H	Inside Motor Cabinet	Service or Warranty Information
I	Inside Motor Cabinet	Caution Keep Hands and Arm from Belt Drive
J	Inside Motor Cabinet	Notice Do Not Overtension Belts

SPECIFICATIONS

Canoga 193-E Specifications	
Model	193-E
Motor*	Baldor 1 Hp 120V
Batch Capacity	1/2 to 3/4 Bag (5 cu. ft.)
Total Volume	9 cu.ft.
Drum Diameter	26"
Drum Depth	3/4"
Drum Opening	16"
Drive	Single V-belts to cast gear
Axle	Torsion-Bar
Wheels	5.0 x 13"
Tires	ST175/80D 13C 6 ply Bias/Load Range C
Dimension (L x W X H)	95" x 62" x 67"
Shipping Weight	700 lbs.
Part Number	163821

*See motor manual for complete motor specifications.

MIXER BASIC COMPONENTS

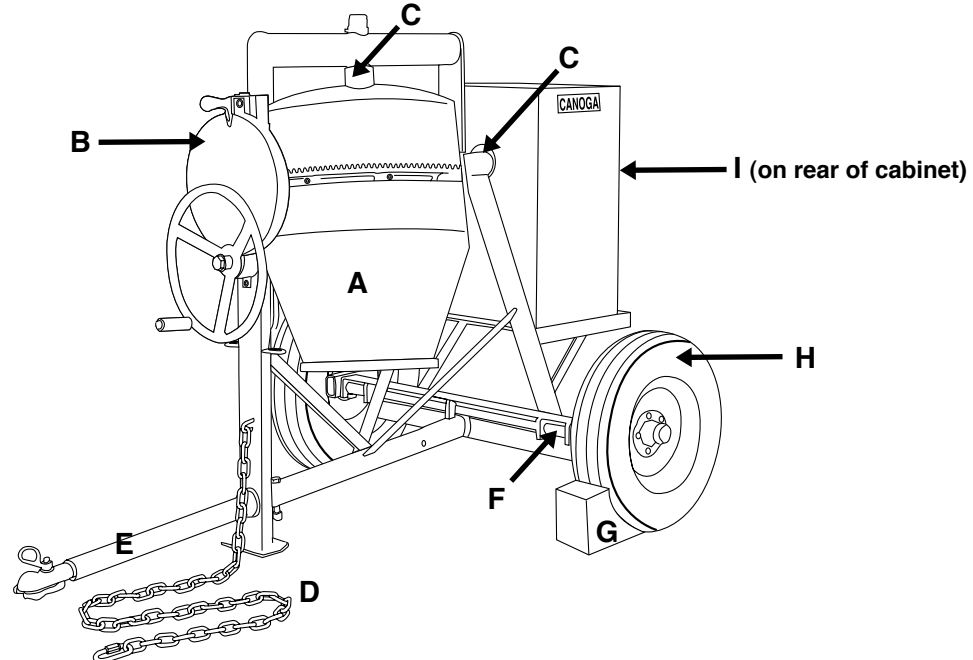

Mixer Major Components

- A. **Steel Mixing Drum** – The Canoga concrete mixer uses an 9 cu. ft. steel mixing drum. This drum is to be used for mixing of concrete. Always clean the drum after each use.
- B. **Dump Gear Guard** – **NEVER** remove the guarding on the dump guard.
- C. **Zerk Fittings** – Zerk fittings are located at the top of the engine side of the yoke and center of the drum bearing. Lubricate these fittings as referenced in the maintenance section of this manual.
- D. **Safety Chain** – This mixer uses a 3/16-inch thick, 72-inches long zinc-plated safety chain. **ALWAYS** connect the safety chain when towing.
- E. **Tow Bar** – This mixer uses various towing bars. Reference the tow bar drawing on page 9 to determine which tow bar meets your requirements.
- F. **Torsion Bar Suspension** – This mixer has a torsion bar suspension that should be inspected periodically.
- G. **Chock Blocks** – Place these blocks (not included as part of the mixer package) under each mixer wheel to prevent rolling, when mixer is not connected to the towing vehicle.
- H. **Tires Ply** – The tire ply (layers) number is rated in letters. This mixer uses 13-inch 2-ply tires. Replace with only recommended type tires.
- I. **Cabinet/Latch** – Encloses gas engine. **NEVER** run mixer with cabinet removed. Use latches to secure motor compartment cabinet.

ELECTRIC MOTOR SAFETY

For maintenance care and operation of the electric motor, refer to your electric motor instruction booklet furnished with the electric motor. Protect the electric motor from dust as much as possible and keep ventilating openings clean. Before plugging in the machine, make sure that the outlet voltage is within the voltage marked on the machines's data plate.



CAUTION



DO NOT spray water on the electric motor. **DO NOT** touch the plug with wet hands. To reduce the risk of electrocution, keep all connections dry and off the ground.



DO NOT operate electric motor in an explosive environment.



WARNING

Use only extensions cords that are intended for outdoor use. These extension cords are identified by a marking, "Acceptable for use with outdoor appliances; store indoors while not in use." Use only extension cords having an electrical rating not less than the rating of the product. Do not use damaged extension cords. Examine extension cords before using and replace if damaged. Do not abuse extension cords and do not yank on any cord to disconnect. Always disconnect the extension cord from the receptacle before disconnecting the product from the extension cord.

Electric Motor Connection

ALWAYS make certain that the power source required for the electric motor is correct and always use the correct NEMA configuration plug. Motors can burn out when the line voltage falls 10% below the voltage rating of the motor. Failure to use proper voltage will cause the motor to overheat. Make certain that the correct size grounded (3-wires) extension cord is used.



WARNING

Use of undersized extension cords result in low voltage to the motor that can result in motor burnout and premature failure. Canoga Equipment warns that equipment returned to us showing signs of being run in a low voltage condition, through the use of undersized extension cords, will be repaired or replaced totally at the customer's expense. There will be no warranty claim.

To choose the proper extension cord,

- Locate the length of extension cord needed in the table below.
- Once the proper length is found, move down the column to obtain the correct AWG size required for that length of extension cord.

EXTENSION CORD LENGTH							
Nameplate Amperes	115V	25'	50'	75'	100'	150'	200'
	250V	50'	100'	150'	200'	300'	400'
0 - 5		16	16	16	14	12	12
5.1 - 8		16	16	14	12	10	•
8.1 - 12		14	14	12	10	•	•
12.1 - 15		12	12	10	10	•	•
15.1 - 20		10	10	10	•	•	•

ELECTRICAL REQUIREMENTS AND GROUNDING INSTRUCTIONS

In order to prevent electrical shock and injury, the following electrical safety precautions and symbols should be followed at all times!

WARNING

In case of a malfunction or breakdown, grounding provides a path of least resistance for electrical current to reduce the risk of electric shock. This tool is equipped with an electric cord which has an equipment-grounding conductor and a grounding plug. The plug must be plugged into a matching outlet that is properly installed and grounded in accordance with all local codes and ordinances.

- **DO NOT** modify the plug provided - if it will not fit the outlet, have the proper outlet installed by a qualified electrician.
- Improper connections of the equipment-grounding conductor can result in a risk of electric shock. The equipment-grounding conductor is the insulated conductor that has an outer surface that is green, with or without yellow stripes. If repair or replacement of the electric cord or plug is necessary, **DO NOT** connect the equipment-grounding conductor to a live terminal.
- Check with a qualified electrician or service personnel if the grounding instructions are not completely understood, or if in doubt as to whether the tool is properly grounded.
- Use only 3-wire extension cords that have 3-prong grounding plugs and 3-pole receptacles that accept the tool's plug.
- Repair or replace a damaged or worn cord immediately.

This tool is intended for use on a circuit that has an outlet that looks like the one shown in Sketch A. The tool has a grounding plug that looks like the plug illustrated in Sketch A. A temporary adapter, which looks like the adapter illustrated in sketches B and C, may be used to connect this plug to a 2-pole receptacle as shown in Sketch B, if a properly grounded outlet is not available. The temporary adapter should be used only until a properly grounded outlet can be installed by a qualified electrician. The green-colored rigid ear, plug, and the like, extending from the adapter, must be connected to a permanent ground, such as a properly grounded outlet box.

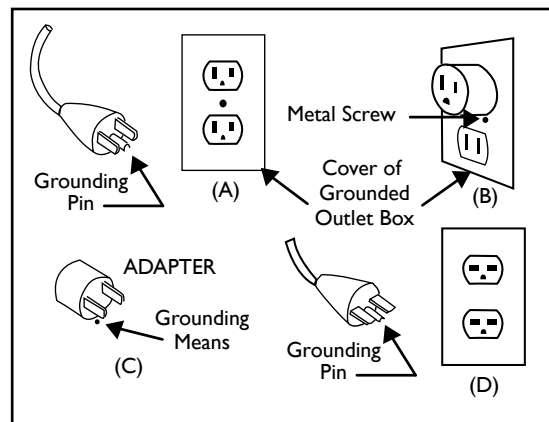

Circuit and Adapter Information

NOTE: Use of a temporary adapter is not permitted in Canada.

NOTE: If permanently connected this tool should be connected to a grounded metal permanent wiring system; or to a system having an equipment - grounding conductor.

**WARNING**

To avoid the possibility of the appliance or plug receptacle getting wet, position the machine to one side of a wall mounted receptacle. This will prevent water from dripping into the receptacle or plug. A "drip loop," shown in the picture below, should be arranged by the user to properly position the power cord relative to the power source. Use the drip loop as a way to prevent GFCI and plug from getting wet.

The "drip loop" is that part of the cord below the level of the receptacle (or the connector, if an extension cord is used). This method of positioning the cord prevents the travel of water along the power cord and coming in contact with the receptacle.

If the plug or receptacle gets wet, **DO NOT** unplug the cord. Disconnect the fuse or circuit breaker that supplies power to the tool. Then unplug and examine for presence of water in the receptacle.

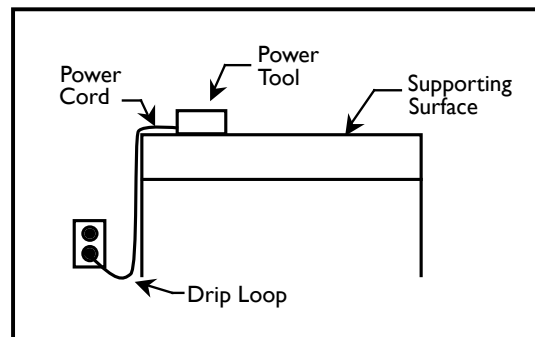

Drip Loop Information

**WARNING**

Use only extension cords that are intended for outdoor use. These extension cords are identified by a marking "Acceptable for use with outdoor appliances; store indoors while not in use." Use only extension cords having an electrical rating not less than the rating of the product. **DO NOT** use damaged extension cords. Examine extension cords before using and replace if damaged. **DO NOT** abuse extension cords and **DO NOT** yank on any cord to disconnect. Keep cords away from heat and sharp edges. Always disconnect the extension cord from the receptacle before disconnecting the product from the extension cord.

ALWAYS make certain that the power source required for the electric motor is correct and always use the correct NEMA configuration plug. Motors can burn out when the line voltage falls 10% below the voltage rating of the motor. Failure to use proper voltage will cause the motor to overheat. Make certain that the correct size grounded (3-wires) extension cord is used.

ELECTRIC MOTOR

Refer to motor manual for detailed information.

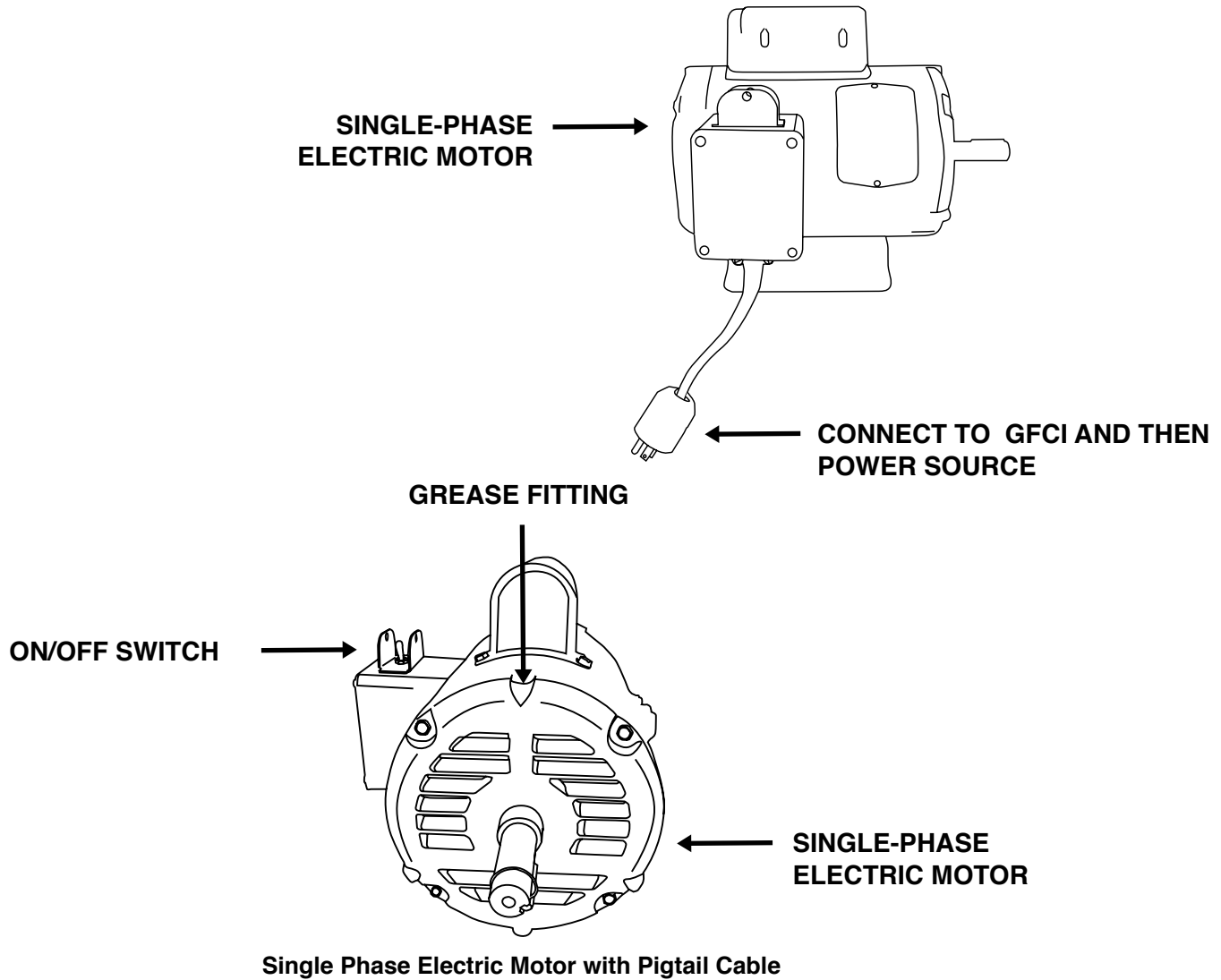

INITIAL START-UP (ELECTRIC MOTOR)

Refer to motor manual for detailed instructions.

⚠ CAUTION

DO NOT attempt to operate the mixer until the Safety, General Information and Inspection sections have been read and understood.

Before starting, make sure mixer is positioned on a secure flat surface to prevent rolling.

Use an extension cord of adequate current carrying capacity (see table on Page 15), insert the electric motor's power plug into one end of the extension cord. See the Recommended Extension Cord Sizes table.

WARNING

NEVER use a worn or frayed extension cord.
NEVER operate mixer with V-belt cover removed.



DANGER

NEVER touch the power cord with wet hands or while standing in water when it is connected to a power source. The possibility exists of electrical shock (electrocution) even death. **NEVER** spray water directly on the electric motor.

Plug the other end of the extension cord into a 120 VAC G.F.C.I. protected receptacle. Remember the power requirements for this electric motor is 120 VAC, 60 Hz. The use of any other input voltage will severely damage the motor.

WARNING

ALWAYS read the label on the electric motor before applying power. The label will indicate the proper power requirements for the motor. Remember the use of any other input voltage will severely damage the motor.

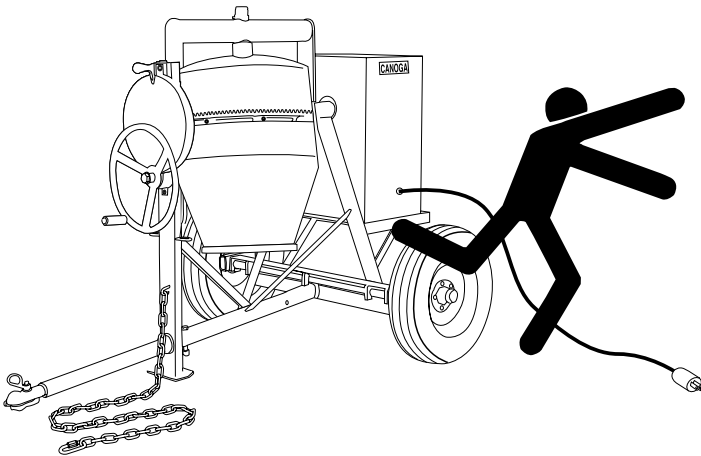

To prevent tripping of personnel,
 position the extension cord so that it
 lays flat and is not curled
 underneath the mixer.

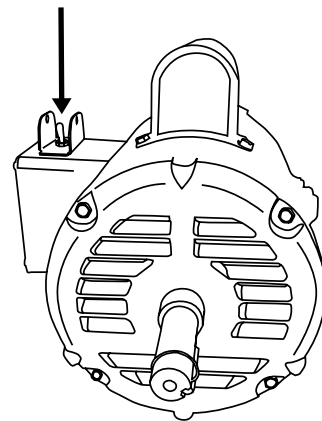
ON/OFF SWITCH

Set the electric motor's **ON/OFF**
 switch to the **ON** position.

CONCRETE MIXING

Application

This mixer is **only** intended for the production of cement concrete. The mixer must be used for its intended purpose and is not suitable for the mixing of flammable or explosive substances. The mixer must not be used in an explosive atmosphere. Refer to the reference table below when mixing concrete for various applications.

CONCRETE MIXING HINTS								
APPLICATIONS	MIX RATIOS	BATCH QUANTITIES					APPROX. BATCH OUTPUT	
		CEMENT 112 lbs. (50 Kgs.) Bag	SAND		STONE			
			CU. FT.	LTR	CU. FT.	LTR	CU. FT.	LTR
Most Ordinary	1:2:4	1/2 BAG	1-1/4	35	2-1/2	71	3	85
Foundations	1:3:6	1/3 BAG	1-1/4	35	2-1/2	71	2-3/4	78
Rough Mass Concrete	1:4:8	1/4 BAG	1-1/4	35	2-1/2	71	2-3/4	78
Watertight Floors, Tanks, Pits, Etc.	1:1-1/2:3	2/3 BAG	1-1/4	35	3	71	3	85

OPERATION

To position the drum, make sure the mixer is placed on firm level ground, then pull up on the dump latch (Figure 1) and turn the hand wheel until the drum is at the desired position. Once the drum is at the desired position, pull down on the dump latch to lock the drum in position.



CAUTION

NEVER stand in front or behind the mixing drum while it is being placed in the dump position. Stay clear of the mixing drum while it is being positioned.

As the drum rotates, use a shovel (Figure 2) to place the cement mix inside the drum, add water as required.

Placing the shovel all the way inside the drum will cause the shovel to strike the blades. This condition could cause injury to personnel. **NEVER** place hands inside the mixing drum while it is rotating (Figure 3).

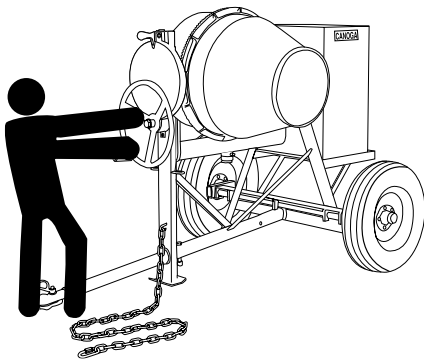

Fig 1. Mixing Drum Positioning

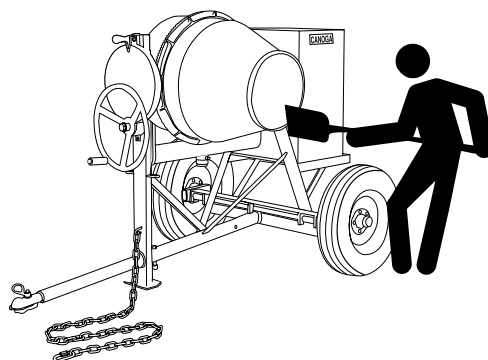

Fig 2. Filling Mixing Drum



Fig 3. Filling Mixing Drum

STOPPING THE MIXER

Turn the main **start/stop** switch to the **STOP** position.
 Push the fuel shut-off lever to the **OFF** position.
 Clear drum of all debris and foreign matter.

TOWING GUIDELINES



CAUTION Check with your county or state safety towing regulations department before towing your mixer.

To reduce the possibility of an accident while transporting the mixer on public roads, always make sure that the mixer towing components and the towing vehicle are in good operating condition and both units are mechanically sound.



CAUTION The following safety should be used when towing the mixer



Make sure that the hitch and coupling of the towing vehicle are rated equal to, or greater than the trailer “gross vehicle weight rating” (GVWR).



If the mixer tow bar is deformed or damaged replace entire tow bar. **NEVER** tow the mixer with a defective tow bar. There exists the possibility of the trailer separating from the towing vehicle.



ALWAYS inspect the hitch and coupling for wear. **NEVER** tow the mixer with defective hitches, couplings, chains etc.



CHECK the tire air pressure on both the towing vehicle and the trailer. Also check the tire tread wear on both vehicles.



ALWAYS make sure the mixer is equipped with a “Safety Chain”.



ALWAYS attach trailer’s safety chain to the frame of towing vehicle.



ALWAYS make sure that the towing vehicle’s directional, backup, and brake lights are working properly.



Remember in most cases the maximum speed unless otherwise posted for highway towing is 45 MPH, however before towing your mixer, check your local state, and county vehicle towing requirements. Recommended off-road towing is not to exceed **10 MPH** or less depending on type of terrain.



When towing of the mixer is required, place the drum in the **DOWN** position (mouth facing **DOWN**).



ALWAYS make sure that the fuel valve lever is in the **OFF** position.



Check wheel mounting lug nuts with a torque wrench. Torque wheel lug nuts as described in the maintenance section of this manual.



Avoid sudden stops and starts. This can cause skidding, or jackknifing.



Avoid sharp turns to prevent rolling.

TOWING GUIDELINES

Tow Bar to Vehicle Connection (Coupler Only)

Check the vehicle hitch ball, and mixer's coupler for signs of wear or damage. Replace any parts that are worn or damaged before towing.

Use only a 2-inch ball diameter (towing vehicle), this will match the mixer's 2-inch coupler. Use of any other ball diameter will create an extremely dangerous condition which can result in separation of the coupler and ball or ball failure.

After tow bar has been connected to mixer, attach mixer's coupler to the hitch ball on the towing vehicle securely and make sure the lock lever is in tight.

Mixer Tow Bar Vehicle Connection (Pintle & Loop)

Make sure the bumper on the towing vehicle is equipped to handle either a pintle or loop type tow bar configuration.

After tow bar has been connected to mixer, secure either type of tow bar to the towing vehicle, following state and county towing regulations.

As a minimum, use a 1/2-inch bolt and nylock nut grade 5 when securing either tow bar to the towing vehicle.

SAFETY CHAIN CONNECTION



CAUTION NEVER tow the mixer with the safety chain removed. The safety chain is intended to prevent complete separation of the mixer from the towing vehicle in the event of a tow bar failure. Reference the figure below for the installation of the Safety Chain.

Tow Bar to Mixer Connection

Insert the tow bar through the round opening at the bottom of the mixer stand. Align the hole on the tow bar with the hole on the mixer frame, and insert 1/2-inch bolt through tow bar and frame. Secure tow bar to frame with 1/2-inch nylock nut. Tighten to 40 ft.-lbs.

Route the safety chain through the holes just above the tow bar, located on each side of the mixer stand. Loop the chain together and place under the tow bar. Secure the loop with the connector link.

Extend the safety chain along the length of the tow bar, looping it through the tow bar's connector link. Remove any excess chain slack.

Connect the free end of the safety chain (clevis safety hook) to the towing vehicle. **Remember it is critical that the length of the chain be properly adjusted**, to prevent the draw bar and the front of the mixer stand from dropping to the the ground (contact) in the event the draw bar becomes disconnected from the towing vehicle.

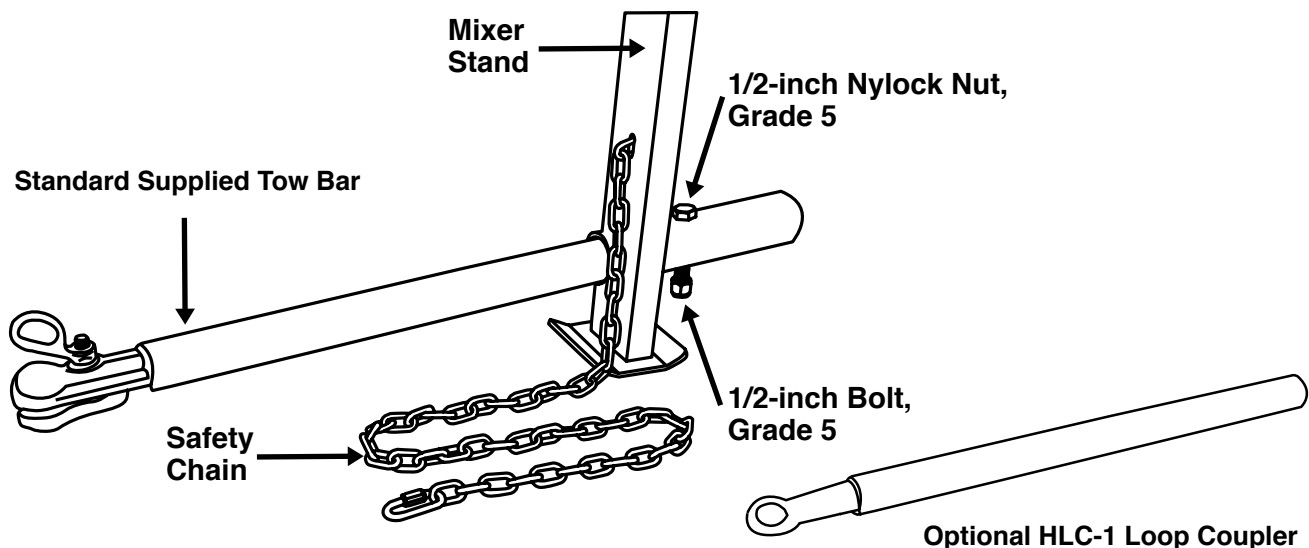

Tow Bar and Safety Chain Installation

Ball Socket and Clamp Face Maintenance

If the towing vehicle is equipped with a ball socket, smear socket periodically with multi-purpose grease. This will keep the ball socket well lubricated.

When parking or storing your mixer. Keep the coupler off the ground so dirt will not build up in the ball socket.

Grease Fittings (Zerk) Maintenance (Mixer)

There are 2 grease fittings that will require lubrication. Lubricate these fittings once a week. Use lithium base grease, grade No.1.

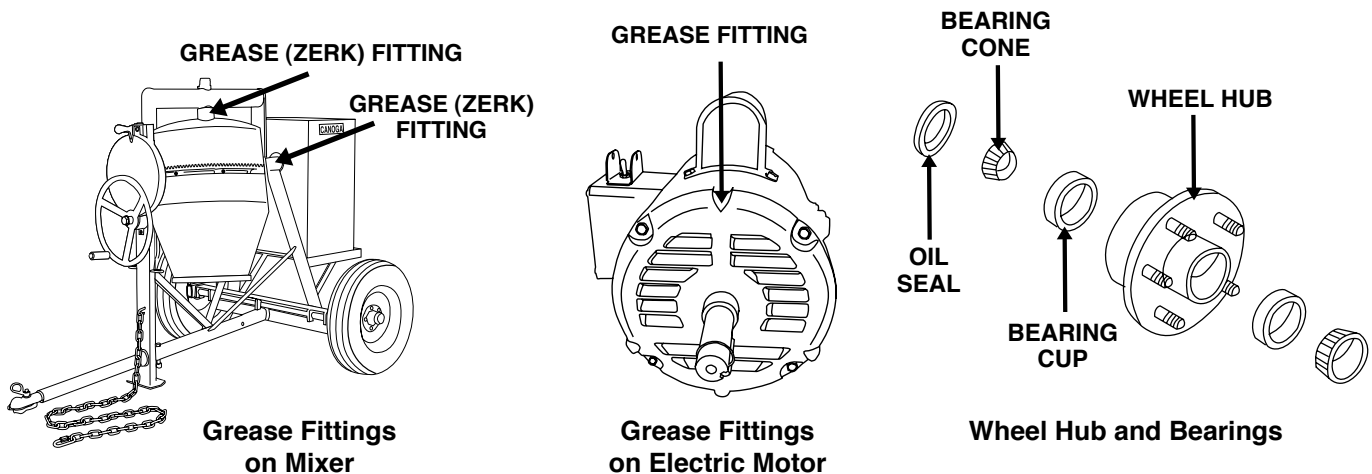

Use Poleyrex EM (Exxon Mobil) or equivalent lubricant. Clean grease fitting, apply grease gun to fitting (1/2 shot). Remember too much grease or injecting grease too quickly can cause premature bearing failure. Slowly apply the recommended amount of grease, taking a minute or so to apply.

Wheel Bearings

After every 3 months of operation, remove the hub dust cap and inspect the wheel bearings. Once a year, or when required, disassemble the wheel hubs remove the old grease and repack the bearings forcing grease between rollers, cone and cage with a good grade of high speed wheel bearing grease (**never** use grease heavier than 265 A.S.T.M. penetration ("No. 2."))

Fill the wheel hub with grease to the inside diameter of the outer races and also fill the hub grease cap. Reassemble the hub and mount the wheel. Then tighten the adjusting nut, at the same time turn the wheel in both directions, until there is a slight bind to be sure all the bearing surfaces are in contact.

Then back-off the adjusting nut 1/6 to 1/4 turn or to the nearest locking hole or sufficiently to allow the wheel to rotate freely within limits of .001" to .010" end play. Lock the nut at this position. Install the cotter pin and dust cap, and tighten all hardware.

Mixer Cleaning

Always wash drum out after each use.

NEVER pour or spray water over the gas engine.

Tires/Wheels/Lug Nuts

Tires and wheels are a very important and critical components of the trailer. When specifying or replacing the trailer wheels it is important the wheels, tires, and axle are properly matched.



CAUTION

DO NOT attempt to repair or modify a wheel. **DO NOT** install an inter-tube to correct a leak through the rim. If the rim is cracked, the air pressure in the inter-tube may cause pieces of the rim to explode (break-off) with great force and can cause serious eye or bodily injury.

Tire Wear/Inflation

Tire inflation pressure is the most important factor in tire life. Pressure should be checked cold before operation. **DO NOT** bleed air from tires when they are hot. Check inflation pressure weekly during use to insure the maximum tire life and tread wear.

The Tire Wear Troubleshooting table will help pinpoint the causes and solutions of tire wear problems.



CAUTION

NOTE: ALWAYS wear safety glasses when removing or installing force fitted parts. Failure to comply may result in serious injury.

Tire Wear Troubleshooting			
WEAR PATTERN		CAUSE	SOLUTION
	Center Wear	Over inflation	Adjust pressure to particular load per the manufacturer.
	Edge Wear	Under inflation	Adjust pressure to particular load per the manufacturer.
	Side Wear	Loss of chamber or overloading	Make sure load does not exceed axle rating. Align wheels.
	Toe Wear	Incorrect toe-in	Align wheels.
	Cupping	Out-of-balance	Check bearing adjustment and balance tires.
	Flat Spots	Wheel lockup & tire skidding	Avoid sudden stops when possible and adjust brakes.

Lug Nut Torque Requirements

It is extremely important to apply and maintain proper wheel mounting torque on the trailer. Be sure to use only the fasteners matched to the cone angle of the wheel. Proper procedure for attachment of the wheels is as follows:

! **NOTICE** **NEVER** use an pneumatic air gun to tighten wheel lug nuts.

Start all wheel lug nuts by hand using a Torque Wrench.

Torque all lug nuts in sequence. **DO NOT** torque the wheel lug nuts all the way down.

Tighten each lug nut in 3 separate passes as defined by Troubleshooting table. After first road use, retorque all lug nuts in sequence. Check all wheel lug nuts periodically.

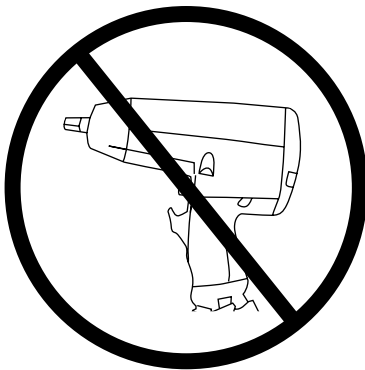

Pneumatic Air Gun

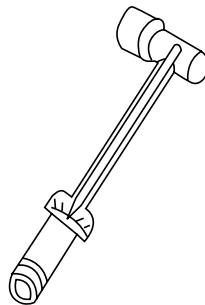

Torque Wrench

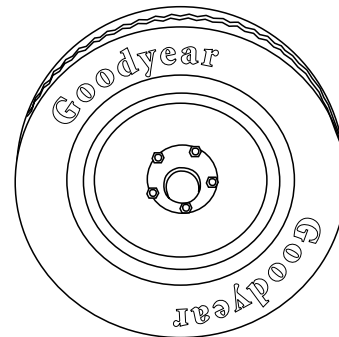

Wheel Lug Nuts Tightening Sequence

Mixer Storage

For storage of the mixer for over 30 days, the following is recommended:

Drain the fuel tank completely, or add STA-BIL to the fuel.

Run the engine until the fuel is completely consumed.

Completely drain used oil from the engine crankcase and fill with fresh clean oil, then follow the procedures described in the engine manual for engine storage.

Clean the entire mixer and engine compartment.

Place the mixing drum in the down position (mouth facing downward).

Cover the mixer and place it a clean dry area, that is protected from harsh elements.

TROUBLESHOOTING

Practically all breakdowns can be prevented by proper handling and maintenance inspections, but in the event of a breakdown, please take a remedial action following the diagnosis based on the Troubleshooting information shown below. If the problem cannot be remedied, please leave the unit just as it is and consult our company's business office or service center.

Mixer Troubleshooting		
SYMPTOM	POSSIBLE PROBLEM	SOLUTION
Drum rotates rough	Defective ring gear?	Check that the ring gear and bearings are not worn. Replace as necessary.
	Defective pinion gear?	Check that the pinion gear and bearings are not worn. Replace as necessary.
	Worn V-belt?	Replace V-Belt.
	Loose pulley?	Tighten or replace pulley.
Drum does not rotate at all	Fuel?	Check level of fuel in fuel tank. Add fuel if necessary. Make sure fuel is being supplied to the engine. Check to ensure that the fuel filter is not clogged.
	Broken V-belt?	Replace V-belt.
	Defective ring or pinion gears?	Check that the gears and bearings are not broken. Replace as necessary.

NOTES

CONTACT

Canoga Equipment is a subsidiary of MK Diamond Products, Inc. Please contact MK Diamond Customer Service with any questions you might have regarding distributors, parts or service.

Telephone: **(800) 421-5830**

Fax: **(310) 539-5158**

E-mail: **Customer_Service@MKDiamond.com**

Customer Service Hours: **Monday through Friday, 6AM-5PM PST**

MK Diamond Products, Inc.

1315 Storm Parkway

Torrance, CA 90501

CANOGA LIMITED WARRANTY

MK DIAMOND PRODUCTS, INC. will guarantee every CANOGA® machine they build, to be free from defects in material and workmanship for (1) one year from date of purchase. The obligation of MK DIAMOND PRODUCTS, INC. under this warranty is limited to the repair or replacement of any parts which, under normal use, prove to be defective in material or workmanship. The parts involved or the unit in question should be returned to MK DIAMOND PRODUCTS, INC. or to a point designated by us, transportation prepaid.

This warranty does not obligate us to bear the cost of labor or transportation charges in connection with replacement or repair of defective parts. Likewise, it shall NOT apply to any unit which has been subjected to misuse, neglect or accident. This warranty does NOT apply to any machine which has been repaired or altered outside our factory.

This warranty does NOT obligate MK DIAMOND PRODUCTS, INC., with respect to items not of our manufacture, such as engines, motors, hydraulics, etc., which are subject to their own guarantees and warranties.

We shall in no event be liable for consequential damages or contingent liabilities arising out of failure of any equipment or parts to operate properly.

© COPYRIGHT 2013, CANOGA EQUIPMENT. ALL RIGHTS RESERVED.

The Canoga logo is a registered trademark of Canoga Equipment and may not be used, reproduced, or altered without written permission. All other trademarks are the property of their respective owners and used with permission.

Canoga Equipment may have patents, patent applications, trade marks, copyrights of other intellectual property right covering this product in this document. This manual MUST accompany the equipment at all times. This manual is considered a permanent part of the equipment and should remain with the unit if resold.

The information and specifications included in this publication were in effect at the time of approval for printing. Illustrations are based on the Model 193 Concrete Mixer. Illustrations, descriptions, references and technical data contained in this manual are for guidance only and may not be considered as binding. Canoga reserves the right to discontinue or change specifications, design or the information published in this publication at any time without notice and without incurring any obligations.



Certificate of Origin for a Vehicle Request Form

Check with your county or state for towing regulations before towing your Canoga mixer. If you require a Certificate of Origin for a Vehicle for your Canoga mixer, please fill out the form and Canoga will send the necessary paper work to your distributor for them to issue your Certificate.

Manufacturer's Certificate of Origin form may also be found online at http://canogamixers.com/vehicle_cert.html

PERSONAL INFORMATION

First Name	Last Name
Company	Address
Address 2	City
State	Zip Code
Email Address	Phone

DISTRIBUTOR INFORMATION

Name	Address
City	State
Zip Code	

CANOGA INFORMATION

Model Number	Part Number
Serial Number	Invoice Number
Date Purchased	

Please return the completed form via email, fax or mail. Forms that are not fully completed cannot be processed.

Fax: (310) 530-3695

Mail: Canoga Products
Customer Service
1315 Storm Parkway
Torrance, CA 90509

CANOGA 193-E SERIES
OPERATOR'S MANUAL



MK Diamond Products, Inc.
1315 Storm Parkway
Torrance, CA 90501

Toll-Free: (800) 421-5830
Phone: (310) 539-5221
Fax: (310) 539-5158
www.mkdiamond.com